



PAPERS PROGRAM

83d Convention, April 21-26

The prospective arrangement of subjects and sessions will be set forth in a postal announcement folder being mailed to all Members late this month. Also in that folder will be the Hotel Reservation card and the SMPTE Advance Registration card and data.

Listed below are some subjects planned for the Program according to information ahead of deadline from *Herb Farmer*, Program Chairman:

“Use of Plastics in Motion-Picture Studios,” a symposium and panel discussion with assistance from the Society of Plastics Engineers, with Dr. Herbert Meyer of the Motion Picture Research Council as moderator.

“New Lenses for TV and Motion-Picture Production”

“Economic Aspects of TV Film Production in Color”

“Recent Advances in Film Laboratory Equipment Design”

“An Automatic 16mm Film Processor”

“Automatic Densitometry”

“Factors Contributing to Steadiness of 16mm Prints”

“Dirt Control and Film Handling Operations”

“16mm Ektachrome Commercial Film”

“Advances in Review Room Equipment and Techniques”

“Language Translation by Machine”

“Developments in Monochrome and Color Video Tape Recording”

A group of *closed-circuit TV* papers already includes:

“Industry Standardization Effort”

“Aspect Ratio Treatment at Bartlesville”

“Generating and Processing TV Signals for Narrow-Band Transmission”

“Sensitivity and Speed of TV Camera Tubes”

“Zoom Lenses for Closed-Circuit Television”

Papers on *Television Recording* already include:

“16mm Color Kinerecording for Theater Projection”

“The BRYG System of Photographic Color Projection for Television”

“High-Fidelity Video Recording Using Ultrasonic Light Modulation”

Five Ampex Corp. papers on: Interchangeability of Recordings; Electronic Conversion to Color Recording; Engineering Planning; Electronic Marking and Control for Editing; Timing and Frequency Requirements.

The above are paper subjects which have materialized at an early date.

Members will be better advised by the mailing late this month, then especially by the Advance Program in the *March Journal*. Hotel information is on p. 106.

Convention Equipment Exhibit

John Olsson, Chairman of the Exhibit Committee, reports that within a week after the mailing of brochures and order forms 14 companies had signed up for a total of 17 booths. At this rate the available space should be practically filled by the time this issue appears.

The response from the industry is a clear indication of the interest many manufacturers and suppliers of professional equipment have in using the opportunity presented by an SMPTE convention, especially on the west coast, to show their products in what is for many of them the only forum in existence where such specialized equipment can be shown.

The companies who have already reserved space are:

Animation Equipment Corp., Booth 203

Bell & Howell Co., Booths 218, 220

Birns & Sawyer, Booth 201

Camera Equipment Co., Booth 212

Great Books of the Western World, Booth 109

Herrnfeld Engineering Corp., Booth 118

Houston-Fearless Div., Booth 101

Kling Photo Corp., Booths 204, 206

Magnasync Mfg. Co., Booth 202

Mole-Richardson Co., Booth 217

Producers Service Co., Booth 104

S.O.S. Cinema Supply Corp., Booth 102

Traid Corp., Booth 219

Westrex Corp., Booths 103, 105

A layout of the space and other information appeared on p. 39 of the January *Journal*.

The area in which the exhibit will be held is the same as at the last Convention in Los Angeles, in 1956. Situated next to the auditorium where the technical sessions are held, it is ideal in arrangement and location and assures maximum convenience for exhibitors and viewers. Anyone who still intends to show equipment at this Convention should telegraph John Olsson, c/o Houston-Fearless Div., 11801 W. Olympic Blvd., Los Angeles 64.

1958 Directory for Members

Re-reminder from the January *Journal*:

Does the label on the envelope in which this *Journal* came to you

or the April 1957 *Journal* Part II have an error or inconsistency in your address or listing?

The 1958 Directory is planned to have the same general content and arrangement as the 1957 Directory. Please send corrections and suggestions to Society Headquarters. New members and new addresses are expected to be included if received by March 5 and they will be taken into account as far as feasible during the remainder of March. Suggestions for improving the Directory will be welcome at any time.—*Ed.*

GOOD NEWS!

ARRIFLEX 16 SHIPMENTS STEPPED UP

Many important motion picture producers, cinematographers, and industrial users waited months—even years—for delivery of Arriflex 16 cameras. With the intense demand for this outstanding equipment far in excess of initial production, a long waiting time was unavoidable.

Today, more new buildings, more new machinery, and a growing staff of highly skilled technicians enable the Arri factory to fill orders with increasing speed.

If you want the ultimate in 16mm cinematography, you will, naturally, turn to the Arriflex 16. Its mirror reflex shutter—not a beam splitter—gives you positive through-the-lens focusing and viewing without loss of lens efficiency, eliminates finders and rack-over devices. A registration pin film movement assures rock-steady screen images. You have a choice of electric motor drives for any purpose including synchronization, animation, or time lapse. Sound blimp, 400 ft. magazines, and wide selection of useful accessories, plus many other built-in features make the Arriflex 16 the outstanding all-round cine camera. What's more its weight of only 6½ pounds makes it ideal for hand-held shooting.

See your franchised Arri Dealer for a complete demonstration.

KLING

PHOTO CORP.

257 Fourth Avenue, New York 10, N. Y.
7303 Melrose Avenue, Hollywood 46, Cal.



Arriflex is a member of the
Kling family of fine
West German photographic products.

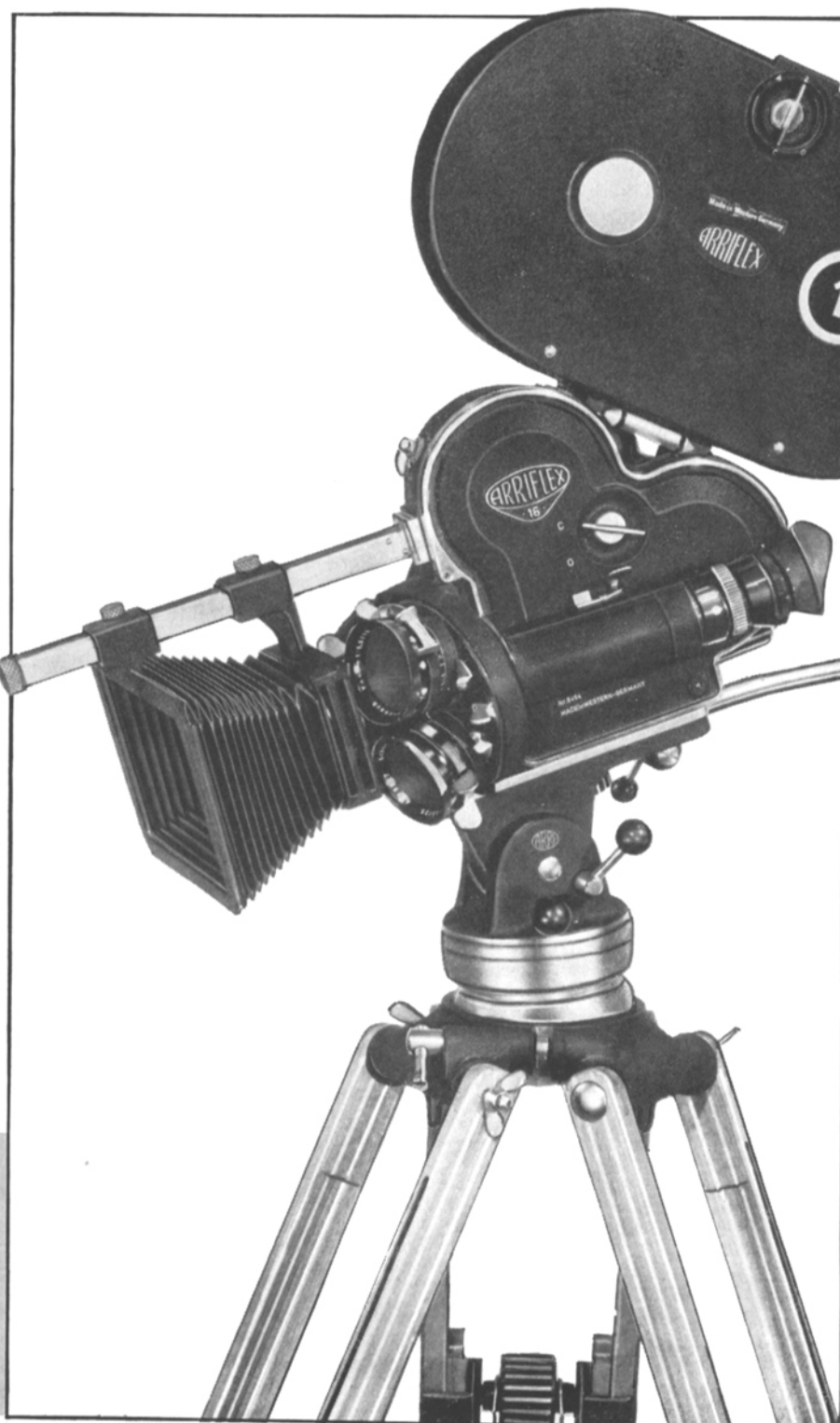

Convention Hotel

Like the last two conventions in Los Angeles, this convention will be held at the Ambassador Hotel. Well located, midway between Hollywood and downtown Los Angeles, the Ambassador has public rooms that are ideally suited and arranged for taking care of our session, exhibit and committee needs. Set among wide lawns and gardens, with a very fine swimming pool, it is also a most attractive spot for members' families to enjoy themselves during the convention.

Rates at the Ambassador are: Single room with bath, \$9.00, \$11.00, \$13.00, \$15.00, \$17.00, \$19.00 per day; double room with bath, \$3.00 additional per day in each case; parlor, bedroom and bath, occupied by one person, \$27.00, \$29.00, \$33.00, \$35.00; parlor, bedroom and bath, occupied by two persons, \$3.00 additional per day in each case. Garden Studios are available with full hotel service and easily accessible to the main building. Rates are: Room with bath, occupied by one person, \$17.00, \$19.00, \$21.00, \$23.00 per day; room with bath, occupied by two persons, \$3.00 additional per day in each case; room with private sun deck or terrace, occupied by one person, \$21.00, \$25.00; occupied by two persons, \$24.00, \$28.00 per day; large living room, bedroom and bath, occupied by one person, \$37.00 per day; with large private sun deck, \$47.00; occupied by two persons, \$3.00 additional in each case.

Reservations can be made with the card included in the postal announcement to all Members or by citing the SMPTE and writing to: Reservation Manager, Ambassador Hotel, 3400 Wilshire Blvd., Los Angeles 5.

Local Arrangements

There is never any lack of things to do at a Hollywood convention. In addition to the Get-Together Luncheon, at which there will be a principal speaker and amenities and levities, and the usual cocktail party, banquet and dance, there will be many other social occasions arranged for convention visitors, including trips to motion-picture and television studios, and an opportunity to visit Disneyland.

Those who are responsible for these arrangements, as well as all other matters to do with making the convention a success, are:

Local Arrangements Chairman — *John W. DuVall*

Exhibits: *John B. Olsson*

Hotel Arrangements: *Dennis F. Godfrey*

Registration: *Lewis Mansfield*

Ladies' Committee Hostess: *Mrs. John W. DuVall*

Hospitality: *Theodore B. Grenier*

Transportation: *Lewis Mansfield*

Banquet: *Sidney Solow*

Luncheon: *Hans de Schulthess*

Projection: *M. Bundy Smith*

Public Address and Recording: *Kenneth Miura and Daniel H. Wiegand*

Publicity: *Marty Waldman*

Membership: *Harry J. Lehman*

Stewart **ONEPIECE** Seamless REAR PROJECTION SCREENS

One of These Three Fits Most Needs

LUXCHROME

FOR VIEWING slides or motion pictures under roomlight conditions; for business, education, research, advertising, display.

PROCESS

FOR PHOTOGRAPHIC BACKGROUNDS; special effects in motion picture and commercial still photography.

TV BLUE

FOR TELECASTING live action in studio against projected "location" backgrounds.

OTHER TYPES AVAILABLE FOR SPECIALIZED USES

STEWART . . . the screen preferred by 9 of the top 10 Hollywood motion picture studios . . . gives you brilliant, sharply defined rear projected images for either viewing or photographing.

You, too, can now have the quality of Stewart award-winning screens, born of the demands of critical motion picture and TV studio technicians. Here is the one truly *onepiece* screen for perfect rear projection, made in all sizes from table-top to large set proportions.

Specialists in professional screens: rear and front projection.

1161 W. SEPULVEDA BLVD.
TORRANCE, CALIF.

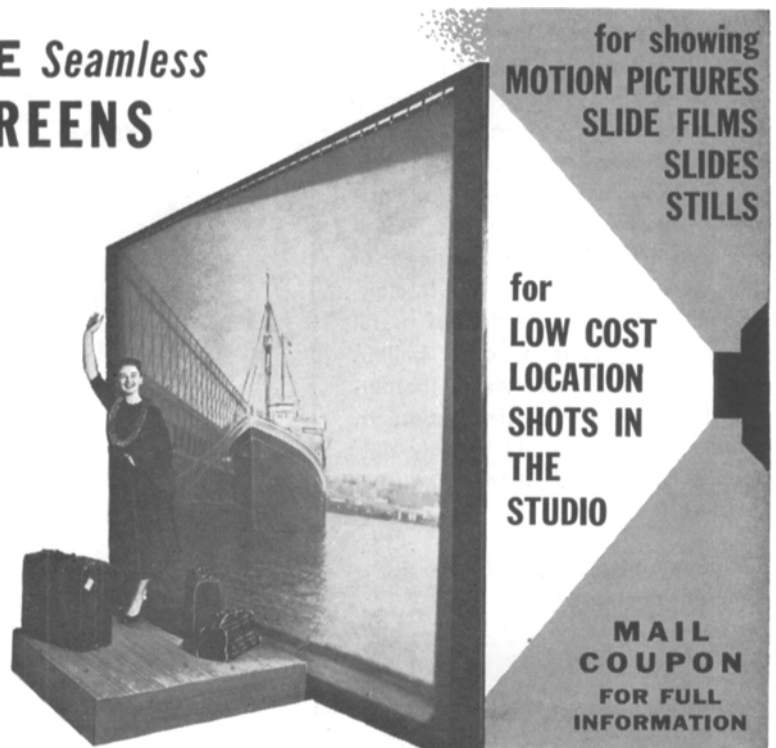

STEWART-TRANS-LUX CORP. DEPT. SMT-2
1161 WEST SEPULVEDA BLVD., TORRANCE, CALIF.

Please send full information on award winning Stewart screens.

Send sample swatches of:
LUXCHROME
PROCESS
TV BLUE

NAME _____
ADDRESS _____
CITY _____ STATE _____

My interest is in: _____

HF
REWINDS and ACCESSORIES

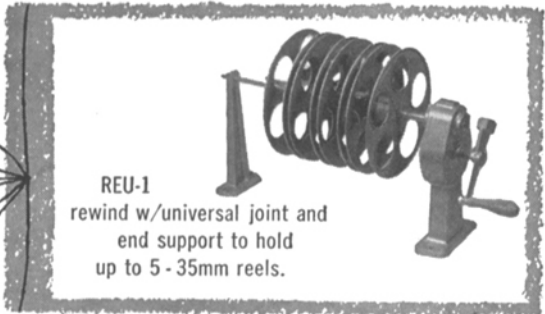

REU-1
 rewind w/universal joint and
 end support to hold
 up to 5-35mm reels.

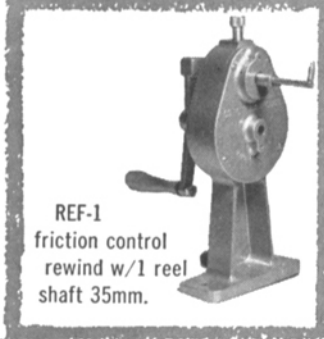

REF-1
 friction control
 rewind w/1 reel
 shaft 35mm.



RETWC-1
 rewind
 w/16-35mm
 combination
 tightwind

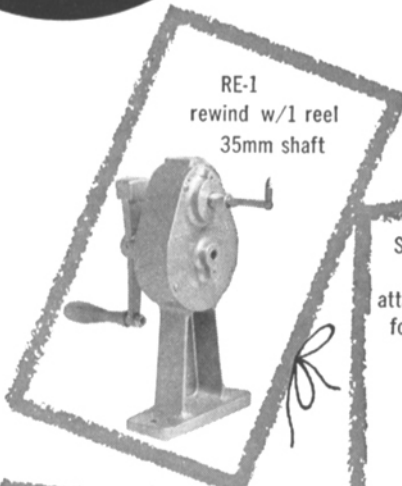

RE-1
 rewind w/1 reel
 35mm shaft



SB-1
 swivel base
 attachment
 for rewind

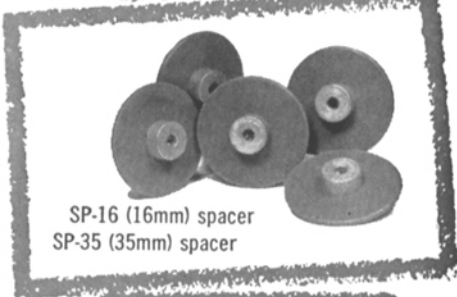

SP-16 (16mm) spacer
 SP-35 (35mm) spacer

IMMEDIATE
 DELIVERY
 FROM STOCK...
 AT BETTER
 DEALERS
 EVERYWHERE



ASC-35
 35mm aluminum shaft
 male or female cores
 ASC-16 (16mm)



SL-1
 spring locks

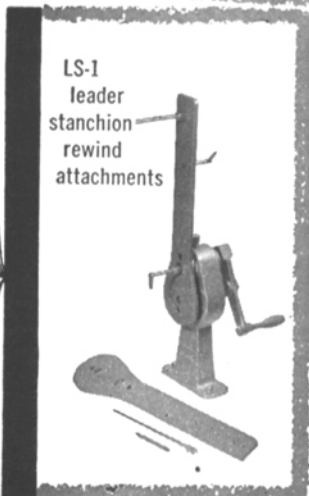

LS-1
 leader
 stanchion
 rewind
 attachments

precision film editing equipment/reels, cans and shipping cases
HOLLYWOOD FILM COMPANY
 956 N. Seward Street, Hollywood 38, California/HOLLYWOOD 2-3284
 branch office:
 HOLLYWOOD FILM COMPANY
 524 W. 43rd St., New York, N. Y./LONGACRE 3-1546
WRITE FOR FREE CATALOGUE