

viewpoints of a question to develop its logical conclusions. This often provided a practical and amicable solution to a seemingly irresolvable situation. Emmett Carver believed in living life at its fullest whether at work or play. Many in the Society of Motion Picture and Television Engineers will cherish their associations with him.—Charles R. Fordyce.



Harry M. Warner

Harry M. Warner, 76, died July 25, 1958, at his home in Bel Air, Calif. One of the "greats" of the motion-picture world, his career began in 1903 when, with his three brothers, Jack, Albert and the late Sam Warner, he acquired a motion-picture projector and opened a 99-seat theater in Newcastle, Pa. In 1923 he and his brothers founded Warner Bros. and for 33 years he served as its President. He retired in 1956. One of the company's most noteworthy achievements was the production in 1927 of the first "talkie," *The Jazz Singer*, which marked the birth of the era of sound. Born in Poland in 1881, his family emigrated to the United States when he was six years of age. The family settled in Baltimore, Md., and later moved to Youngstown, Ohio, where he opened a bicycle shop. Shortly thereafter he became interested in motion pictures and after opening the Newcastle theater, he exhibited *The Great Train Robbery* and others of the very early films. Shortly before his death he and his brothers were cited by the Motion Picture Pioneers for "vision and enterprise in bringing sound to the screen, for their boundless courage in blazing a new path in screen entertainment and public service and for their unswerving faith in motion pictures and in their industry as a bulwark of the American way of life."

Membership Certificates (Active and Associate members only). Attractive hand engrossed certificates, suitable for framing for display in offices or homes, may be obtained by writing to Society headquarters, at 55 West 42nd St., New York 36, Price: \$2.50.

Smooth, steady CAMERA MOBILITY at a Low Price



Here's the solid support and steady, smooth-rolling action of a pedestal at the price of a tripod-dolly combination. The Houston Fearless PD-10 is designed for all monochrome TV cameras. Ideal for 16mm and 35mm motion picture cameras. Accommodates all standard heads.

Rolls easily, quietly on large 8" rubber, ball bearing wheels which can be locked in parallel for dolly shots or left free for extreme maneuverability. Telescoping legs can be extended for maximum stability or shortened for narrow passageways. Between takes, camera can be quickly, easily raised or lowered with hydraulic jack. Maximum height to top of column: 60". Minimum: 35". Completely disassembles for easy transport. A precision-built, high quality unit in every respect. Send coupon for full details now.

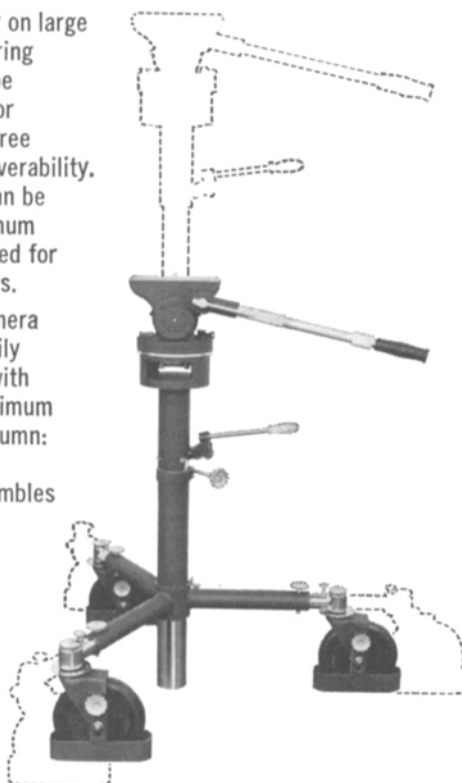

Head not included



HOUSTON FEARLESS CORPORATION
11813 W. Olympic Blvd., Los Angeles 64, Calif.

- Please send catalog and prices on PD-10 Pedestal
 Other Pedestals Dollies Tripods
 Heads Remote Control Heads
 Film Processors Parabolas

Name _____
 Firm _____
 Address _____
 City _____ Zone _____ State _____