

The Exhibit Chairman, Keith Lewis, recently opened up the exhibit space to general allocation of booths. So far, the following companies have reserved space for their equipment:

| | |
|-------------------------------------|--------------------------------------|
| Arriflex Corp. of America | Edgerton, Germeshausen & Grier, Inc. |
| Avco Research & Advanced Dev. Div. | Fairchild Camera & Instr. Corp. |
| Beckman & Whitley, Inc. | Field Emission Corp. |
| Benson & Lehner, Inc. | Florman & Babb, Inc. |
| Camera Equipment Co. | Dr.-Ing. F. Früngel GmbH |
| Computer Measurements Co. | General Aniline & Film Corp. |
| E. I. du Pont de Nemours & Co. Inc. | Anso |
| Eastman Kodak Co. | Systems Development Dept. |

| | |
|----------------------------|----------------------------------|
| Heico, Inc. | Photo Sonics Inc. |
| Karl Heitz, Inc. | Polaroid Corp. |
| Hi Speed Equipment, Inc. | Prestoseal Mfg. Co. |
| L-W Products | Traid Corp. |
| Motion Picture Enterprises | Westinghouse Elec. Co. Lamp Div. |
| Neumade Products Corp. | Wollensak Optical Co. |
| D. B. Milliken Co. | Carl Zeiss Inc. |
| O'Connor Engineering Labs | Zoomar, Inc. |
| Photo-Animation Inc. | |

Other companies wishing to exhibit their products in the space still remaining should contact Keith Lewis, Eastman Kodak Co., 1000 Connecticut Ave., N.W., Suite 1101, Washington 6, D.C.

5th Congress-Papers by Session Subjects

Short Duration Light Sources

- Holdover in Xenon Flash Lamps, *Dr. Harold E. Edgerton and David Cahlander, Dept. of Electrical Engineering, Massachusetts Institute of Technology, Cambridge, Mass.*
- The Control of High-Power Xenon Flashes by Magnetic Switching, *Dr. E. J. G. Beeson, AEI Lamp & Lighting Co. Ltd., Milton Road, Leicester, England.*
- Flash-Light Source Measurement, *George H. Lunn, Aldermaston, Berks, England*
- Utilisation de Lampes Explosives Pour la Photographie par le Système Schardin, *Dr. Louis Deffet, Centre de Recherches Pour l'Industrie des Produits Explosifs (and Laboratoires des Hautes Pressions) Tir National, Place des Carabiniers, Brussels, Belgium; and R. Vanden Berghe, Centre de Recherches Scientifiques et Techniques Pour l'Industrie des Produits Explosifs, Val du Bois, Sterrebeek, Brabant, Belgium.*
- Explosive Flashlight—A New Development in an Explosion Light Source, *R. H. Stressau, 7 Summit Rd., Lake Zurich, Ill.; and Jack Gershon, 6245 North Oakley Ave., Chicago, Ill.*
- High-Intensity Explosive Light Sources, *Zev Pressman, Stanford Research Institute, Stanford Village, Menlo Park, Calif.*
- High-Intensity Fractional Microsecond Light Source, *Earle B. Brown, Farrand Optical Co., 4401 Bronx Blvd., New York, N.Y.*
- Millimicrosecond Light Source With Increased Brightness, *Dr. Heinz Fischer, CRRCP, L. G. Hanscom Field, Bedford, Mass.*

Applications of Light in High-Speed Photography

- High-Speed Photography Using Ultra-Violet Light to Eliminate Visible Light Masking In Self-Illuminating Events, *R. Wayne Anderson, Photo Lab., The Dow Chemical Co., Midland, Mich.*
- Die Anwendung der Mehrfachfunkenkamera bei der Untersuchung von Vorgängen, die eine hohe Gesamtinformation verlangen, *Dr.-Ing. H. Schardin, Rosentr. 10, Weil am Rhein, Baden, West Germany.*
- Motion Pictures of Rapid Air Currents and Shockwaves by Means of High-Frequency High-Voltage Sparks, *Dr.-Ing. Frank Früngel, Walter Thorwart and H. G. Patzke, Dr.-Ing. Frank Früngel GmbH, Hamburg-Rissen, Germany.*
- A Modern Shadowgraph System for Use in High-Velocity Aeroballistic Ranges, *Paul Thurston, Paul H. Cords, Jr., and W. R. Noyes, Photographic Div., U.S. Naval Ordnance Laboratory, White Oak, Md.*
- Submicrosecond Flash Sources, *Dr. Harold E. Edgerton, K. W. Cooper and J. Tredwell, Massachusetts Institute of Technology, Cambridge, Mass.*
- A High-Intensity Square Pulse Light Source for High-Speed Photography, *Lemuel L. Hill, Gas Dynamics Div., U.S. Naval Ordnance Laboratory, White Oak, Silver Spring, Md.*

Electric and Electronic Shutters

- Image Converter System With Fast Image Group Repetition Rate, *John H. Hett and R. King, Hett Associates, 24 Burton Place, Cresskill, N.J.*
- Development of Photographic Electronic Shutter Tubes, *L. Mandell, Imperial College of Science and Technology, London, England.*
- The "Astrocon" Tube and Its Application to High-Speed Photography, *A. E. Anderson and G. W. Goetze, Physics Project Laboratory, Westinghouse Research Laboratories, Beulah Rd., Churchill Borough, Pittsburgh 35, Pa.*
- A Kerr-Cell Camera With Synchronized Light Source for Millimicrosecond Reflected-Light Photography, *George A. Theophanis, Avco Corp., Research & Advanced Development Div., 201 Lowell St., Wilmington, Mass.*
- Multiple Kerr-Cell System With Square Shuttering Characteristics, *Dr.-Ing. Frank Früngel and L. Liebing, Dr.-Ing. Frank Früngel GmbH, Hamburg-Rissen, Germany.*

Stereo, Spectra and Micro Studies

- Design and Application of a High-Speed Time-Resolving Spectrograph, *Donald Baker Moore and John K. Crosby, Stanford Research Institute, Stanford Village, Menlo Park, Calif.*
- High-Speed Spectroscopic Instruments, *Dr. F. D. Harrington, U.S. Naval Research Laboratory, Washington, D.C.*
- A Stereoscopic High-Speed Framing-Camera Technique for the Study of Shaped-Charge Liner Collapse, *Bradley O. Reese, Stanford Research Center, Stanford Village, Menlo Park, Calif.*
- High-Speed Photographic Recording of Dual Data at High Magnification, *B. H. Amstead, College of Engineering, University of Texas, Austin 12, Texas.*
- High-Speed Motion-Picture Photography of Microscopic Phase Changes, *Dr. J. E. Benjamin and J. W. Westwater, 213 East Chemistry Bldg., Division of Chemical Engineering, University of Illinois, Urbana, Ill.*

Cameras: Sweep and Streak

- An *f/1* Streak Camera for Use in the Ultra-Violet, *J. Dyson, R. F. Hemmings and R. T. Waters, Associated Electrical Industries Ltd., Research Laboratory, Aldermaston Court, Aldermaston, Berks, England.*
- Streak Camera Development at the National Research Council, *E. H. Dudgeon, National Research Council, Division of Mechanical Engineering, Ottawa, Canada.*
- The Improved *f/10* Sweeping-Image Camera: A Versatile Model for Explosive Research, *Berlyn Brixner, P.O. Box 1663, Los Alamos, N.M.*
- A High-Speed Rotating Mirror With Greater Dynamic Resolution, *Willard E. Buck, Box 357, Boulder, Colo.*
- VFK-UVQJM High-Speed Drum Camera, *Jam Hampl, Meopta Optics and Fine Mechanics, Research Institute, Prerov, Czechoslovakia.*

Photo-Sonics, Inc., designed to solve a unique feature—a rotary disc between film and prism—these high resolution

PRECISION PHOTOGRAPHIC INSTRUMENTATION

produces a full line of rotary prism cameras your instrumentation problems. By the use of a shutter located fine cameras produce extremely sharp pictures with over the entire frame.

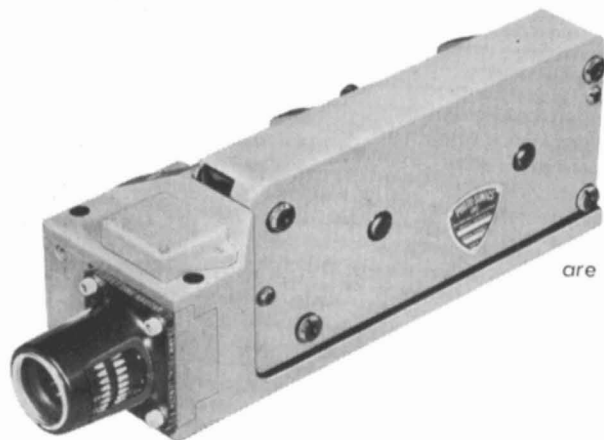

The
PHOTO SONICS
16mm-1B ...
Designed for high "G" loads.
Produces 16mm full frame
pictures at 12 to 1000
frames per second.
Film magazine capacities
are 100, 200, 400, and
1200 feet.

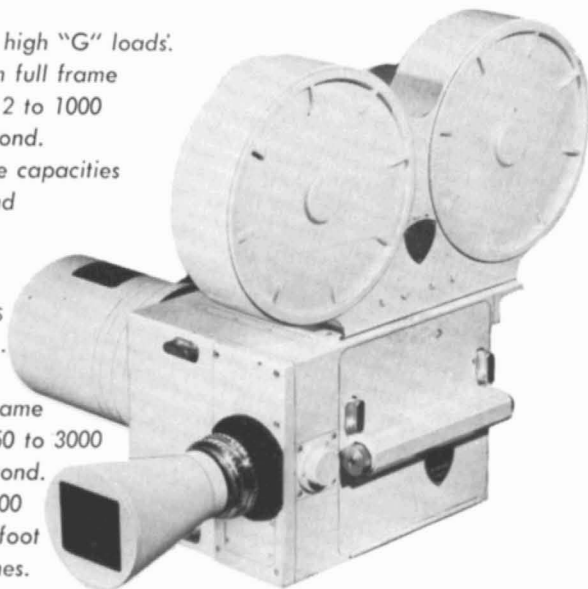

The
PHOTO-SONICS
35mm-4B ...
Produces 35mm
full frame
pictures at 250 to 3000
frames per second.
Uses 500
and 1000 foot
magazines.

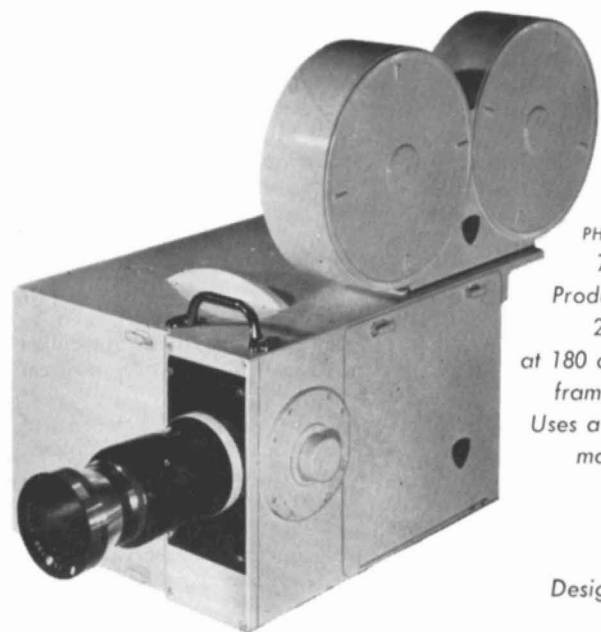

The
PHOTO-SONICS
70mm-10B ...
Produces full frame
2.25" x 2.25" pictures
at 180 and 360
frames per second.
Uses a 400 or 1000 foot
magazine.

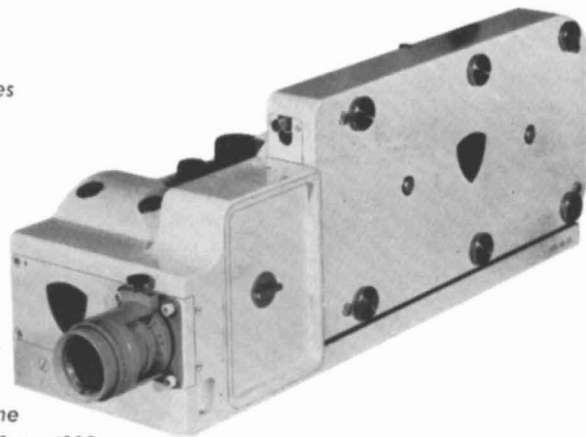

The
PHOTO-SONICS
16mm-1C ...
Designed for extremely
high "G" loads.
Produces 16mm full frame
pictures at 1000 to 4000
frames per second. Utilizes a
400 foot magazine.

to solve your photographic instrumentation problems, contact

Photo-Sonics, Inc. 820 SOUTH MARIPOSA STREET, BURBANK, CALIFORNIA

Cameras: Rotating Mirror and Smear

The CORE Camera (Continuous Receptivity—One Rotating Element), *J. N. Whyte, A.R.D.E., Fort Halstead, Sevenoaks, England.*

A New Ultra-High-Speed Framing Camera Combining a Rotating Mirror With a Film Drum, *T. Uyemura, Institute of Industrial Sciences, University of Tokyo, Yayoi-Cho, Chiba-City, Japan.*

Model 200, Reflecting Optics, Sweep Camera, *Thure Anderson, 18829 Lamson Rd., Castro Valley, Calif.*

Smear-Camera Techniques, *T. P. Liddiard, Jr., and B. E. Drimmer, U.S. Naval Ordnance Laboratory, White Oak, Md.*

Intensification Techniques

High-Sensitivity Television as an Aid to Low Light-Level Photographic Recording, *B. A. Bang, Bendix-Friez, 1400 Taylor Ave., Baltimore, Md.*

Electronic Image Intensification—An Image Intensifier Using Cathode-Conductivity, *Robert A. Chippendale and J. R. Folkes, A. E. I. Research Laboratory, West Road, Templefields, Harlow, Essex, England.*

Very-High-Gain Image-Intensifier Systems and the Photography of Single Photons With Microsecond Time Resolution, *Martin L. Perl and Lawrence Jones, Physics Dept., University of Michigan, Ann Arbor, Mich.*

Tirage des Photographies Sous-Exposées par les "Contrasteurs Optiques," *Miche! Cloupeau, Laboratoire de Recherches Electromiques de la Sorbonne, 11 rue Pierre Curie, Paris 5, France.*

Flash X-ray

50-Millimicrosecond Flash X-Ray Photography System for Hypervelocity Research, *Dr. W. P. Dyke, Linfield Research Institute, McMinnville, Ore.; and Frank J. Grundhauser, 210 Ford St., McMinnville, Ore.*

Installation Triple de Radiographie Eclair à 600 kv, *Dr. J. Viard, Poudrerie Nationale, Sévran, Seine-et-Oise, France; and L. Beaudouin, 16 Rue Roger Salengro, Aulnay s/Bois, Seine-et-Oise, France.*

X-Ray Flash Cinematography of Small Objects, *Heiny Alberti, Dr.-Ing. Frank Früngel and Walter Thorwart, Dr.-Ing. Frank Früngel GmbH, Hamburg-Rissen, Germany.*

Megovolt Flash X-Ray Equipment, *E. W. Walker, A.W.R.E., Aldermaston, Berks, England.*

Applications of Flash Radiography, *J. S. McVeagh, A.R.D.E., Sevenoaks, Kent, England.*

X-Ray Flash Cinematography up to 12,000 Images/S., *A. Stenzel, Hauptstr. 193, Weil am Rhein, Germany; and Dr. G. Thomer, Hauptstr. 274, Weil am Rhein, Germany.*

Application of Image Intensifier in Flash Radiography, *Dr. G. Thomer, Hauptstr. 274, Weil am Rhein, Germany; and Dr. Rudi Schall, Rosenstr. 11, Weil am Rhein, Germany.*

High-Speed Radiographic and Optical Techniques Applied to Hypervelocity Impact Studies, *J. William Gehring, Jr., Ballistic Research Laboratories, Aberdeen Proving Ground, Md.*

Measurements on the Density of Gas in an Argon-Discharge by Soft X-Ray Flashes, *Karl Vollrath, Rosenstr. 12, Weil am Rhein, Germany.*

Unusual Techniques

New Methods in Design and Computing for Special Optical Systems, *Raphael Boolsky, Ave. de Miremont 10, Geneva, Switzerland.*

Unusual Application of Optical Instrumentation at NOTS, *D. Keyes, W. Koiner, W. Lambert, G. Silberberg and D. Tiemann, USNOTS, China Lake, Calif.*

Some Unconventional Methods of High-Speed Photography, *Dr. J. S. Courtney-Pratt, Bell Telephone Labs., Murray Hill, N.J.*

Cameras: Multiple-Shuttered

High-Speed Intermittent-See, *Robert L. Rodgers, D. B. Milliken Co., 131 North Fifth Ave., Arcadia, Calif.*

A Rotating-Mirror Framing Camera Based on a Focal-Plane Shutter Principle, *Dr. Sigmund J. Jacobs, J. D. McLanahan and P. F. Donovan, U.S. Naval Ordnance Laboratory, White Oak, Silver Spring, Md.*

The Use of Focal-Plane Shutters in Rotating-Mirror Framing Cameras, *Dr. Sigmund J. Jacobs, U.S. Naval Ordnance Laboratory, White Oak, Md.*

Kerr-Cell Framing Camera, *W. C. Goss, R. 1257, Bldg. 112, Lawrence Radiation Laboratory, University of California, P. O. Box 808, Livermore, Calif.*

Tripod Size High-Speed Framing Camera, *R. J. Krumhansl, 451 La Vista Rd., Walnut Creek, Calif.*

Materials for High-Speed Photography

A Comparison of 35mm High-Speed Films Under Forced Development Conditions, *Zev Pressman, Stanford Research Institute, Stanford Village, Menlo Park, Calif.*

High-Speed Direct Recording Papers, *Herman D. Hunt, E. I. du Pont de Nemours & Co., Inc., Photo Products Dept., Parlin, N.J.*

Sur les Causes des Ecart de Réciprocité aux Tres Courts Temps de Pose, *Dr. Henri Sauvenier, Université de Liège, 1A Quai Roosevelt, Liège, Belgium.*

A Photometric Study of Brief Light Sources Associated With Photographic Emulsions, *M. Philbert and C. Veret, Office National d'Etudes et de Recherches Aéronautiques, 29-39 Ave. de la Division-Leclerc, Chatillon-sous-Bagneux, Seine, France.*

Applications: Ballistics

The New Technique for Measurement of Velocity of High-Speed Objects, *W. W. Atkins and D. A. Hall, U.S. Naval Research Laboratory, Washington 25, D.C.*

Study of Chemical Reactions in Gases Emerging From the Muzzle of a Gun by Means of High-Speed Photography, *Prof. Kartar Singh, Faculty of Chemistry and Metallurgy, Institute of Armament Studies, Kirkee, Poona 3, India.*

Microsecond Observations of the Dynamic Response of Explosives to Very High Rates of Loading, *R. H. Stressau, 7 Summit Rd., Lake Zurich, Ill.; and H. Napadensky and J. Savitt, Armour Research Foundation, Illinois Institute of Technology, 10 West 35 St., Chicago 16, Ill.*

High-Speed Measurement of Shock Compressibility of Solids in the 1 Mb Range, *Dr. Rudi Schall, Rosenstr. 11, Weil am Rhein, Germany.*

A Photographic Technique for Observing the Behavior of Porous Materials When Rapidly Compressed, *R. H. Stressau, 7 Summit Rd., Lake Zurich, Ill.; and H. Napadensky and J. Savitt, Armour Research Foundation, Illinois Institute of Technology, 10 West 35 St., Chicago 16, Ill.*

Application of the Slit-Aperture Camera for Observation and Data Acquisition, *Stanley Keen, Development and Proof Services, Aberdeen Proving Ground, Md.*

Applications: Miscellaneous in Industry

The Micro-Photography of Dilute Fiber Suspensions Moving at High Speed, *E. L. Scott, The Mead Corp., Chillicothe, Ohio.*

High-Speed Photography in the Development of a New Form of Pulveriser, *Dr. Ronald Jackson, British Coal Utilization Research Association, Randalls Road, Leatherhead, Surrey, England.*

Fundamental Research and New Theories in Canning Machinery as Developed by High-Speed Motion Picture Studies, *C. C. Collier and John J. Larish, 103 East Maple, Hoopston, Ill.*

A Variety of Applications of High-Speed Photography at Outboard Marine Research Center, *Daniel H. Lamb, Outboard Marine Corp., Research Center, 4109 North 27 St., Milwaukee 16, Wis.*

World-Famous Suppliers Of
Professional Movie Equipment
Stocking Thousands Of Items

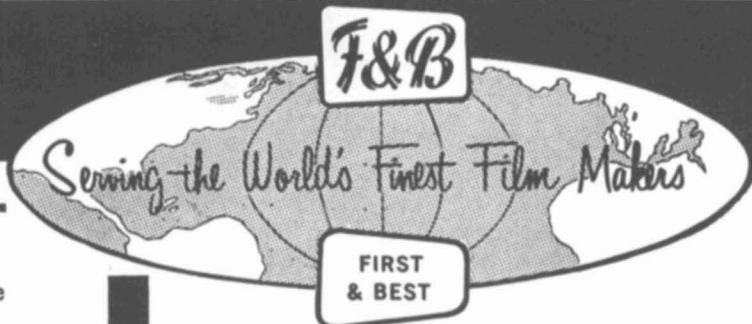

New F & B POLE SET

An Easy Way to Hold Things Up... Anywhere
Lights • Props • Backgrounds • Mikes
Without Nails or Screws

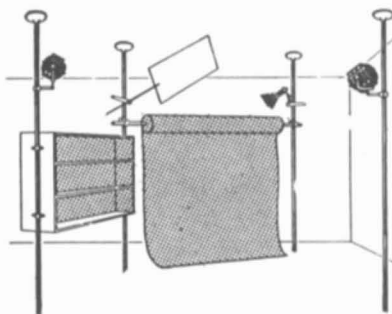

\$34⁹⁵

per set
consisting of:
2—3-piece poles
7—fittings
1—110" cross bar
Adjustable from
8½' to 12½'

F & B POLE SET is a featherweight, telescoping aluminum column with an expansion spring in the top. Adjust it once to your ceiling height with locking collar. Then just spring it in and out of place as you please. Rubber pads top and bottom protect ceilings and floors... can't be knocked over and takes less floor space than a silver dollar. A perfect, mobile, lightweight support for lights. Two POLE SETS with cross piece and fitting can be used to hold a roll of background paper, props, flats, etc. Perfect for location filming.

POLE SET 10½' to 15'... **\$38.95**

Individual Parts:

3 piece Pole
with Clamp
8½' to 12½'
\$8.50 ea

3 piece Pole
with Clamp
10½' to 15'
\$9.50 ea

Cross Bar
(110") with
5 fittings
\$8.50 ea

More PORTMAN ANIMATION STANDS Sold To:

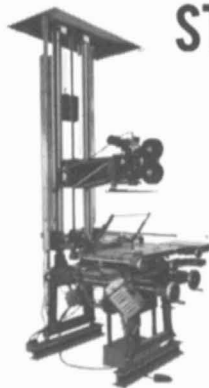

- Australian Broadcasting Commission
- Robert Tinfo Technical Animation
- Bay State Film Productions
- Walter Craig Productions
- Avacugho Cine, Caracas
- Ford Motor Company
- Rembrandt Films
- Ansel Studios
- Corwin Studios
- L & L Animation
- Mayo Clinic
- Slide-O-Chrome

A rugged precision and versatile animation stand that offers more than 40 accessories for special animation and effects.

Prices begin at
\$1595

AVAILABLE NOW:

New ACME-PORTMAN 16mm-35mm interchangeable camera with ball-bearing mounted cam-rackover. Write for descriptive folder and price list.

NEW F & B POWER-MITE NICKEL CADMIUM BATTERIES



7½ Volt—Power-Mite battery (6 cells)\$ 85.00
15 Volt—Power-Mite battery (12 cells)\$135.00
Attached voltmeter—optional\$ 20.00
Battery Charger\$ 29.50
Charging Rate Ammeter\$ 10.00

F & B's Power-Mite batteries can be supplied in any combination to power practically all cameras, recorders, etc. All the features are absolutely guaranteed by F & B. The Power-Mite nickel cadmium battery is unconditionally guaranteed for one full year. SPECIAL BATTERIES CUSTOM-BUILT TO YOUR ORDER.

Replace Worn Leather Moviola Belts With

NEW F & B LIFETIME MOVIOLA BELTS

Made of
Texturized
Seamless Neoprene
Guaranteed to
Outlast the Moviola

No Hooks • No Staples
Firm Friction Grip

Fits All Moviolas

Price only \$2.00

MILLER FLUID DRIVE HEAD



The Miller Head is the world's finest precision built hydraulic drive pan head, and is designed for super-smooth panning and tilting. Can be used with any movie camera. F & B is exclusive distributor of the Miller Fluid Heads in the Eastern United States.

Model D (medium duty) \$150.00
Swivel leveling joint 59.50
Pro Head (heavy duty) 299.50

For Complete Information On Any Item, Write:

FLORMAN & BABB, INC.

68 West 45th Street • New York 36, New York • MUrray Hill 2-2928

High-Speed Photographic Studies of Electrically Exploded Metal Films and Wires, *K. N. Kreyenhagen, Explosive Ordnance Div., Aerojet-General Corp., Azusa, Calif.; and G. Woffinden and Dr. Louis Zernow, Aerojet General Corp., Downey, Calif.*

Values and Problems of High-Speed Photography

Method for Analysis of High-Speed Films, *Dr. F. Topfer, 15 Rue Sohet, Liège, Belgium.*

Some Philosophical Aspects of High-Speed Photographic Instrumentation, *Morton Sultanoff, Ballistic Research Labs., Aberdeen Proving Ground, Md.*

What Is the Sensitivity of a Photographic System?, *F. H. Perrin, Research Laboratories, Eastman Kodak Co., Rochester 4, N.Y.*

Study of Resolution Limits in High-Speed Recording, *Thomas E. Holland, Beckman & Whitley, Inc., 993 San Carlos Ave., San Carlos, Calif.*

Value Received — The Use of High-Speed Photographic Techniques in Research and Industry, *R. Wayne Anderson, Photo Lab., The Dow Chemical Co., Midland, Mich.*

Applications: Survey Papers

Review of High-Speed Camera Facilities at U.C.L.R.L., *Dr. David C. Oakley, Lawrence Radiation Laboratory, Livermore, Calif.*

Progress in High-Speed Recording at A.W.R.E., *K. R. Coleman and A. Skinner, A.W.R.E., U.K. Atomic Energy Authority, Aldermaston, Berks, England.*

The Evolution of Photographic and High-Speed Cinematographic Techniques at the Laboratoire Central de l'Armement Since the Congress in Paris in 1954., *Dr. Paul Devaux, Laboratoire Central de l'Armement, Arcueil (Seine), France.*

High-Speed Photography Applied to High-Speed Aerodynamics at the National Physical Laboratory, Teddington, *R. J. North, Aerodynamics Div., National Physical Laboratory, Teddington, Middlesex, England.*

A Review of Photographic Instrumentation for Ballistic Data Acquisition, *L. E. Davidson, Engineering Labs., Aberdeen Proving Ground, Md.*

Application: High-Speed Flow Dynamics

A Study of the Structure and of the Ultrasonic Emission From A High-Speed Jet of Air Using an Ultra-Rapid Electronic Camera, *François Canac and Mlle. M. Merle, Centre de Recherches Scientifiques, Industrielles et Maritimes de Marseille, 66, rue St.-Sebastian, Marseille (B. du R.), France.*

Photographic Investigation of a Fluid Jet Impinging on a Heated Plate, *G. F. Cochrane and Ralph G. Nevins, Mech. Eng. Dept., Kansas State University, Manhattan, Kansas.*

The High-Speed Photography of Liquid/Solid Impact, *Dr. J. H. Brunton, PCS Laboratory, Free School Lane, University of Cambridge, England.*

A Photomicrographic Arrangement Applied to the Study of the Atomization of Liquid Carburants in a Combustion Chamber, *M. Diamant, 8 Place d'Iéna, Paris 16, France.*

Photographic Study of Time Variations in the Drop-Size Distribution of a Liquid Spray, *M. F. Heidmann, NASA, Lewis Research Center, 21000 Brookpark Rd., Cleveland 35, Ohio.*

High-Speed Photography of Hypersonic Phenomena by Schlieren-Interferography, *H. Oertel, Institut France-Allemand de Recherches, St. Louis, Haut-Rhin, France.*

Über das Modellverhalten von Wirbeln im Stosswellenrohr, *Heinz Reichenbach, Katharinenstr. 25, Freiburg i/Br, Germany.*

Concluded on p. 498

Educators . . .

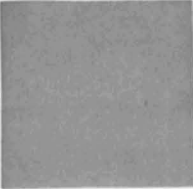
- 
- Make sure you get the most out of your 16mm sound films
 - Use the standard tests your own projector repairman uses
 - Measure your projector's performance yourself with the

16mm "JIFFY" TEST FILM

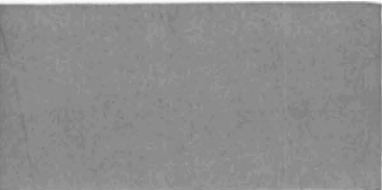
- 
- Points up both projection and sound troubles
 - Instruction booklet supplied with the film
 - Test instruments are not required. Write . . .

SOCIETY OF MOTION PICTURE AND TELEVISION ENGINEERS
55 West 42nd Street, New York 36, New York

MICROFILMING
AERIAL PHOTOGRAPHY
MASS PORTRAITURE
INSTRUMENTATION

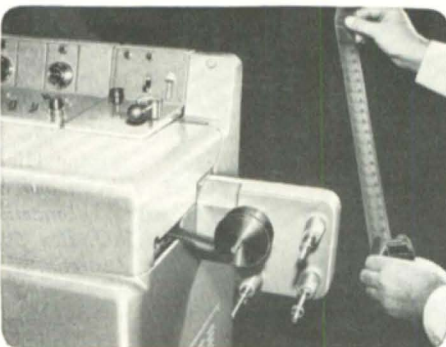
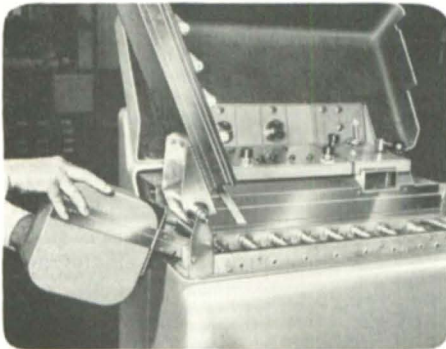
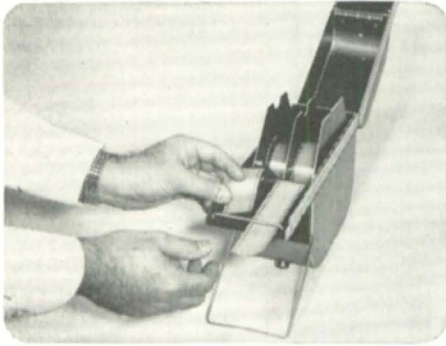

FILM PROCESSING SIMPLIFIED

CARL Tri-Film Processor

develops and dries automatically

- Simple daylight loading magazine
- Magazine inserted—no special leaders required
- Film connected directly to tendency-driven take-up spools
- Processed film completed at up to 6 feet per minute

The Mark 3 Automatic Tri-Film Processor develops and dries 16, 35 and 70 mm. film at 1½, 3 or 6 feet a minute. Separate temperature control of the processing solutions from 60 to 110 degrees F. is possible within ±1 degree. Processing is controlled by a mechanical program unit after the film is daylight loaded, and positive squeeze rollers reduce the need of stop baths and interbath rinses. The processor is perfect for newsreels, motion picture rushes, microfilm and all types of negative/positive cinematography where speed plus quality is essential.

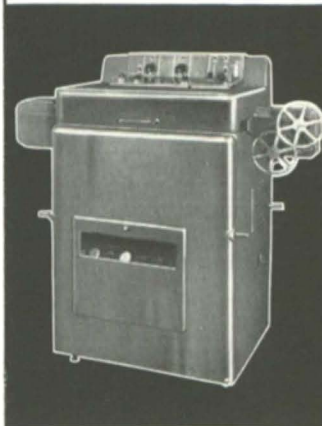

SPECIFICATIONS
SIZE: 54" long, 22" wide, 51" high
WEIGHT: 550 lbs.
POWER: 5KVA maximum single-phase: 110 volts, 45 amps., or to customer requirements.

CAPACITY:
16 mm. 1 to 4 rolls } length
35 mm. 1 to 2 rolls } to
70 mm. 1 roll } 400 ft.
PROCESS RATE: 1½, 3 or 6 ft. a minute.

Western U.S. Representatives
Gordon Enterprises
5362 North Cahuenga Blvd.
North Hollywood, Calif., U.S.A.

CANADIAN APPLIED RESEARCH LIMITED

750 Lawrence Avenue West, Toronto 19, Ontario, Canada

**ELECTRONICS • MECHANICS • OPTICS
DESIGNING • ENGINEERING • MANUFACTURING
ENVIRONMENTAL TESTING • REPAIR AND OVERHAUL**



where ideas
become reality

Canadian Representatives for
LIBRASCOPE, CIE. CROUZET,
ROBOT-FOTO

MEMBER: A. V. ROE CANADA LIMITED & THE HAWKER SIDDELEY GROUP

GUARANTEED QUALITY USED EQUIPMENT

| | |
|---|------------|
| Cameras Arriflex 16mm w/matt box 16mm, 25mm, 50mm Xenon Lenses..... | \$1,400.00 |
| Cineflex 35mm camera w/200 ft. mag., 12 volt DC motor, and power cord..... | 300.00 |
| Film camera w/spider turret, new type finder, and Frezzo-lite bracket. No Lens..... | 150.00 |
| Bell & Howell 35mm Standard camera #616 w/170° shutter, unit I shuttle, overhauled and re-finished..... | 2,500.00 |
| Berndt-Maurer 16mm Single System Camera, w/sound equipment, galvo, amplifier, 3 lenses, two 400 ft. mag., and six cases..... | 1,850.00 |
| Cine Special camera w/4 lens turret and 100 ft. mag..... | 450.00 |
| Maurer 05 Camera Head Only w/built-in features and one 400 ft. mag..... | 2,000.00 |
| Auricon Pro 200 16 Camera w/VA galvo complete w/amplifier, mike and cable..... | 1,200.00 |
| Editing Neumade 35mm film measuring machine w/4 digit counter that measures footage only, 8 frame, 32 tooth sprocket hub with individual controlled tension rollers..... | 40.00 |
| Moviola editing machine (UCS) 35/35 old model cutters machine only, no take up arms, optical composite sound..... | 375.00 |
| Houston Fearless Panoram Dollies thoroughly overhauled, guaranteed: | |
| 4-Wheel..... | 1,400.00 |
| 5-Wheel..... | 1,800.00 |
| Mikro Kilar 40mm lens..... | 150.00 |
| Spectra 2—Color Meter..... | 200.00 |
| Filmline Model "K," 16mm Neg. Positive Processor, w/air compressor, syphon and transfer pump, angle iron stand, 1200 ft. capacity..... | 1,000.00 |
| Sound Magnasync recorder, 16mm X-400.... | \$ 600.00 |
| Projection GPL—Jan Projector w/speakers—Genova Movement..... | 1,000.00 |
| Lighting Colortran Jr. Kit..... | 137.50 |
| CAMERA EQUIPMENT CO., INC. Dept. JS, 315 West 43rd St., N. Y. 36 | |



RENTALS

Lights
Cameras
Accessories

More professionals deal with CECO more often! Why? Because CECO has anything and everything they need for Motion Picture and TV Production ready on a moment's notice. Everything from an Arc to a midget spot.

And remember, you boys who are "headin' South", CECO's Florida office is fully prepared to handle your every equipment rental requirement.

Branch:
CAMERA EQUIPMENT CO., INC. OF FLORIDA
1335 East 10th Avenue • Hialeah, Florida

SALES • SERVICE • RENTALS



Department JS-64 315 West 43rd Street, New York 36,
New York • JUDSON 6-1420

Gentlemen:
Please rush me your FREE complete catalogue of Rental Equipment.

Name _____
Firm _____
Street _____
City _____ Zone _____ State _____

Lighting: Arcs—Incandescents
—Spots—Floods—Dimmers—
Reflectors—All Lighting Accessories

Cameras: 16mm & 35mm—Sound
(Single or Double System)—Silent
—Hi-Speed

Lenses: Wide angle—Zoom—Tele-
photo—Anamorphic

Sound Equipment: Magnetic—
Optical—Mikes—Booms

Grip Equipment: Parallels—
Goboos—Other Grip accessories

Dollies: Crab—Western—Portable
Panoram—Cranes

Generators: Portable—Truck
Mounted

Editing Equipment: Moviolas
—Viewers—Splicers—Rewinders

Projection Equipment: 16mm &
35mm—Sound & Silent—Slide—
Continuous

Television: Closed Circuit TV

O'hare Camera Cars

**CECO—Trademark of Camera
Equipment CO.**

Conclusion of list of technical papers
to be presented at the 5th International
Congress on High-Speed Photography

Applications: Miscellaneous

Application of High-Speed Photography
in Nuclear Reactor Development,
*George W. Lindholm, Argonne National
Laboratory, 9700 South Cass Ave., Argonne,
Ill.*

The Use of High-Speed Photography
and Photoelastic Coatings for the
Determination of Dynamic Strains,
*Major C. A. Cole and J. F. Quinlan, U.S.
Naval Medical Field Research Laboratory,
Camp LeJeune, N.C.; and J. F. Zand-
man, Instruments Div., The Budd Co., P.O.
Box 245, Phoenixville, Pa.*

Underwater High-Speed Photography,
*J. V. Pfaum, 2536 Norfolk St., National
City, Calif.*

Photographic Problems, Techniques and
Instrumentation in Sea Animal Loco-
motion Studies, *Dr. Irving Rehman, 5153
Tampa Ave., Tarzana, Calif.*

Control Systems

Quenching Spark Gaps as Trigger
Element in High-Speed Motion Anal-
ysis Cinematography, *Walter Thorwart
and Dr.-Ing. Frank Früngel, Dr.-Ing.
Frank Früngel GmbH, Hamburg-Rissen,
Germany.*

Precision Speed Control of a High-Speed
Camera, *David Cahlander, Massachusetts
Institute of Technology, Cambridge, Mass.*

Remote Control Unit for High-Speed
Multiple Motion, *Fred Metlen, 1705
Summit Ave., Boeing Airplane Co., Seattle,
Wash.*

An Automatic Control System for a
High-Speed Cine Camera, *John G. G.
Hempson, Ricardo & Co., Ltd., Shoreham-
by-Sea, Sussex, England.*

A New Approach to Ultra High-Speed
Camera Control, *Gordon A. Greene and
E. Godin, Sandia Corp., Sandia Base,
Albuquerque, N.M.*

Pulse Program Generator, *Jakob H. Hohl
and R. Munger, Research Laboratory,
IBM Corp., Zürichstr. 108, Adliswil-
Zürich, Switzerland.*

Trigger Unit for High-Speed Camera,
*C. P. Johnson and S. A. Lott, Defence
Standards Laboratories, Department of
Supply, P.O. Box 50, Ascot Vale, W2,
Victoria, Australia.*