

An Installation for Triple X-Ray Flash Photography at 600 kv

PAPER D-2

BY JEAN VIARD and LUCIEN BEAUDOUIN

Three armored cells are arranged at an angle of 120° to each other, and each one contains a generator of flash x-rays. The object to be examined, an explosive, is in the center of symmetry of the setup. The eight-step shock generators produce a shock of 600 kv 300 joules. The synchronization to a precision of $0.1 \mu\text{sec}$ is assured and the flashes can be delayed in relation to each other from 0 to $100 \mu\text{sec}$. The times can be checked afterwards by means of an oscillographic device. The tubes are of the type with conical anode and cold cathode and can operate either as diodes or triodes. Their bulb is made of glass and is sealed. Cylindrical screens protect it from tungsten vapors. The source diameter depends upon the diameter of the anode. The operation of these tubes with regard to voltage, intensity and x-ray emission has been closely studied, both in diode and triode arrangement. It was found again that there is an emission of a plasma from the anode as has been reported already by Zuckermann.

IF IT is necessary to take several x-ray flash photographs of a single phenomenon with intervals of several microseconds, the two main problems which will immediately arise are (1) image separation and (2) production and synchronization of flashes.

It is well known that residual ionization makes it impossible to obtain several flashes in sufficiently rapid succession from one x-ray tube. It is therefore necessary to have as many tubes as there are flashes and, consequently, as many shock generators as there are tubes. To a certain degree these shock generators have to be independent of each other in order to avoid interference and, at the most, they may be fed from a common source.

The image separation may be obtained by arranging the x-ray beams at certain angles around the event, so that the tubes are installed in an arc, or in a circle, with the object under observation in the center.

In the arrangement which we have chosen there are only three tubes, and these are set in a circle, in the center of which is the phenomenon to be studied.

Presented on October 18, 1960, at the Fifth International Congress on High-Speed Photography in Washington, D.C., by Jean Viard, Poudrerie Nationale, Sevran, Seine et Oise, France, and Lucien Beaudouin (who read the paper), Commissariat à l'Énergie Atomique, 69 rue de Varenne, Paris, France.

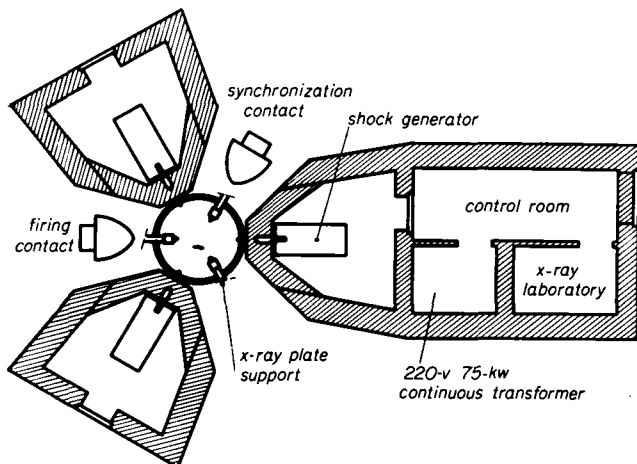

Fig. 1. Layout of three tubes in a circle around event to be studied.

General Description of Main Features of the Installation

By installing the three x-ray flash sets at angles of 120° around the object under observation, each of the armored cells which house a set is subject to the same stress. A cylindrical steel ring protects the front part of the cells from the shock wave. See Figs. 1, 2 and 3. The walls which are not protected by this ring are hit by the shock waves at such an angle that their effect is greatly reduced.

The design of the ring has been calculated on the basis of American studies which were adapted by R. Paoli

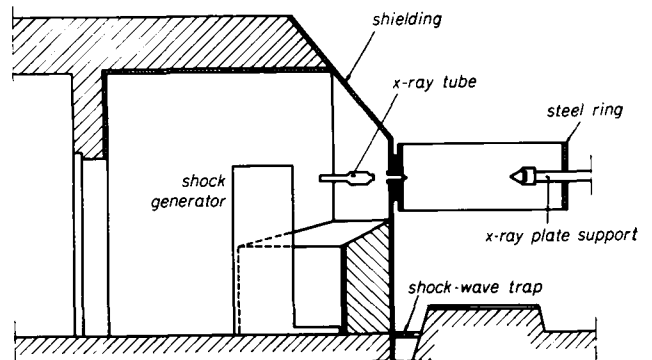

Fig. 2. Sectional elevation of layout.

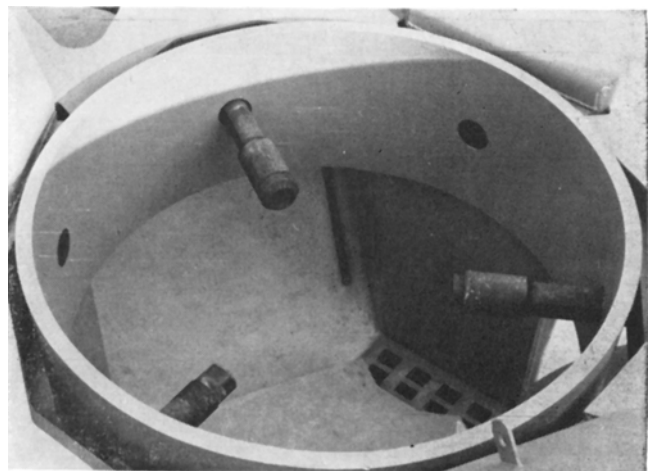

Fig. 3. Photograph of layout.



Fig. 4. A typical set of x-ray photographs of a detonating fuse.

(*Ann. Ponts et Chaussées*, 126: (2) 127-161, 1956) and led to the following dimensions: inside radius, 1 m; thickness, 6 cm; and height, 80 cm.

The ring has six holes at angles of 60° . Three of these serve as x-ray windows, and the supports for the x-ray plate holders pass through the remaining three.

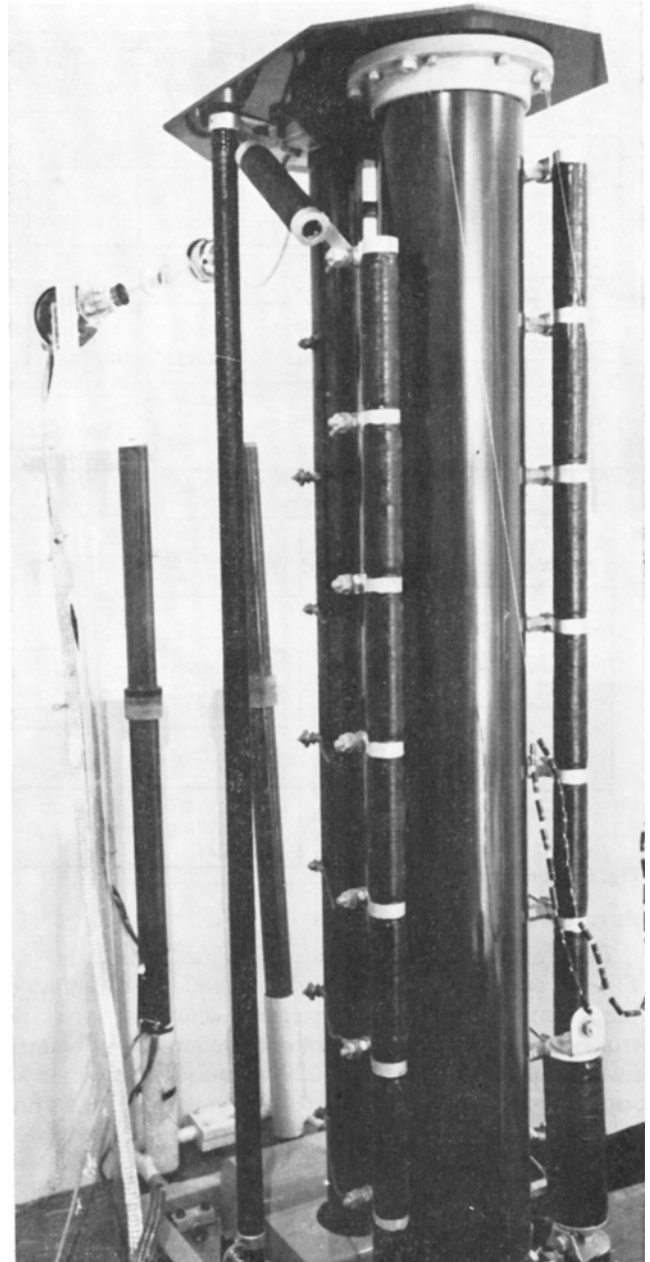

Fig. 5. A shock generator.

The three optical axes theoretically converge on the center of the whole assembly, but in practice they do not meet, though the shortest distance between them at the center is less than 5 mm. The respective distances between anode, object and film are such as to produce a magnification of $1.34\times$.

The cells are constructed of reinforced concrete with a wall thickness of 60 cm. The front ends are covered with armoured plates which form a Faraday cage so that the shock generators do not influence one another. The grounding is distributed over a surface of 100 sq m under the whole firing area and is common to all the instruments.

The cells are connected with each other by a number of underground ducts that contain the electric cables. The cables are distributed among several ducts in order to avoid induction effects caused by high-voltage shocks.

Two small concrete shelters near the firing area house the firing and synchronization contacts.

A typical set of three x-ray pictures is shown in Fig. 4.

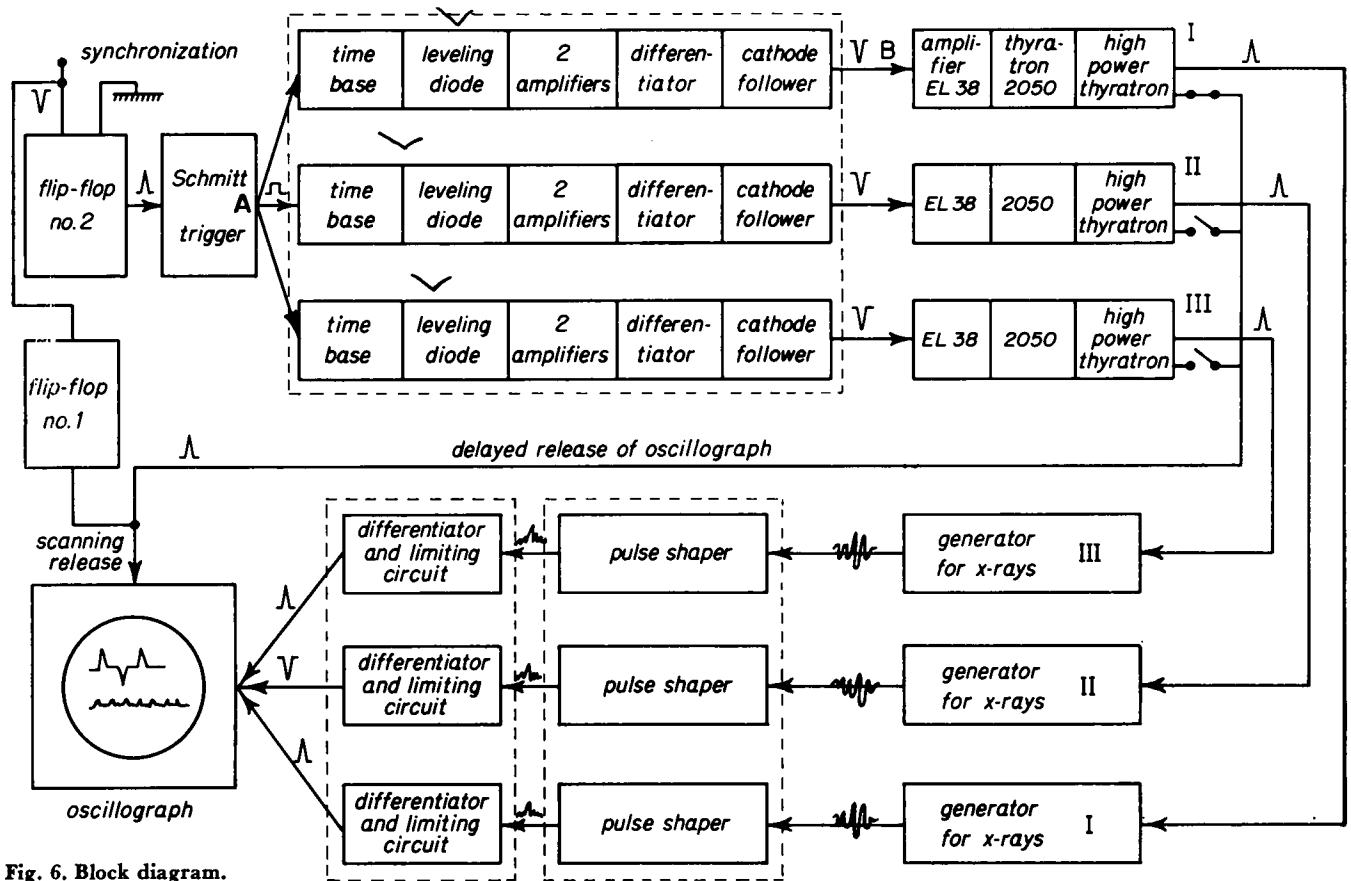

Fig. 6. Block diagram.

Arrangement of Apparatus

Each armored cell contains one shock generator (see Fig. 5), one x-ray tube and one air conditioner. One of these armored cells has an extension which houses a control room (containing control console and chronometric instruments), a room for a 220-v/75-kv transformer for supplying the three shock generators and, lastly, a small laboratory for preparing and developing the x-ray pictures.

Protection of Tube and Photographic Plate

The x-ray tube is protected by a plate of magnesium 2-mm thick inside the cell, and by an aluminum cone and cylinder 2-mm thick outside the cell. This latter is released automatically from its housing by the shot.

In the same way an aluminum cone protects each photographic plate.

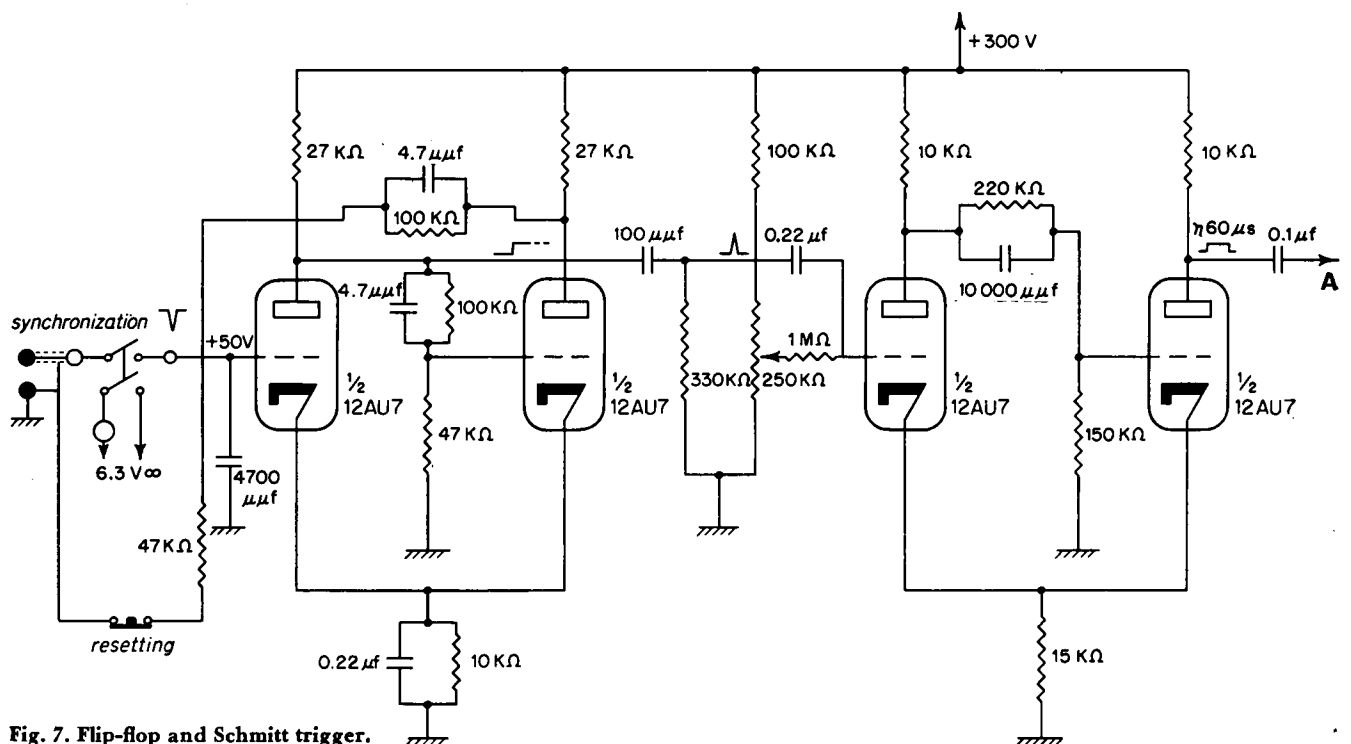

Fig. 7. Flip-flop and Schmitt trigger.

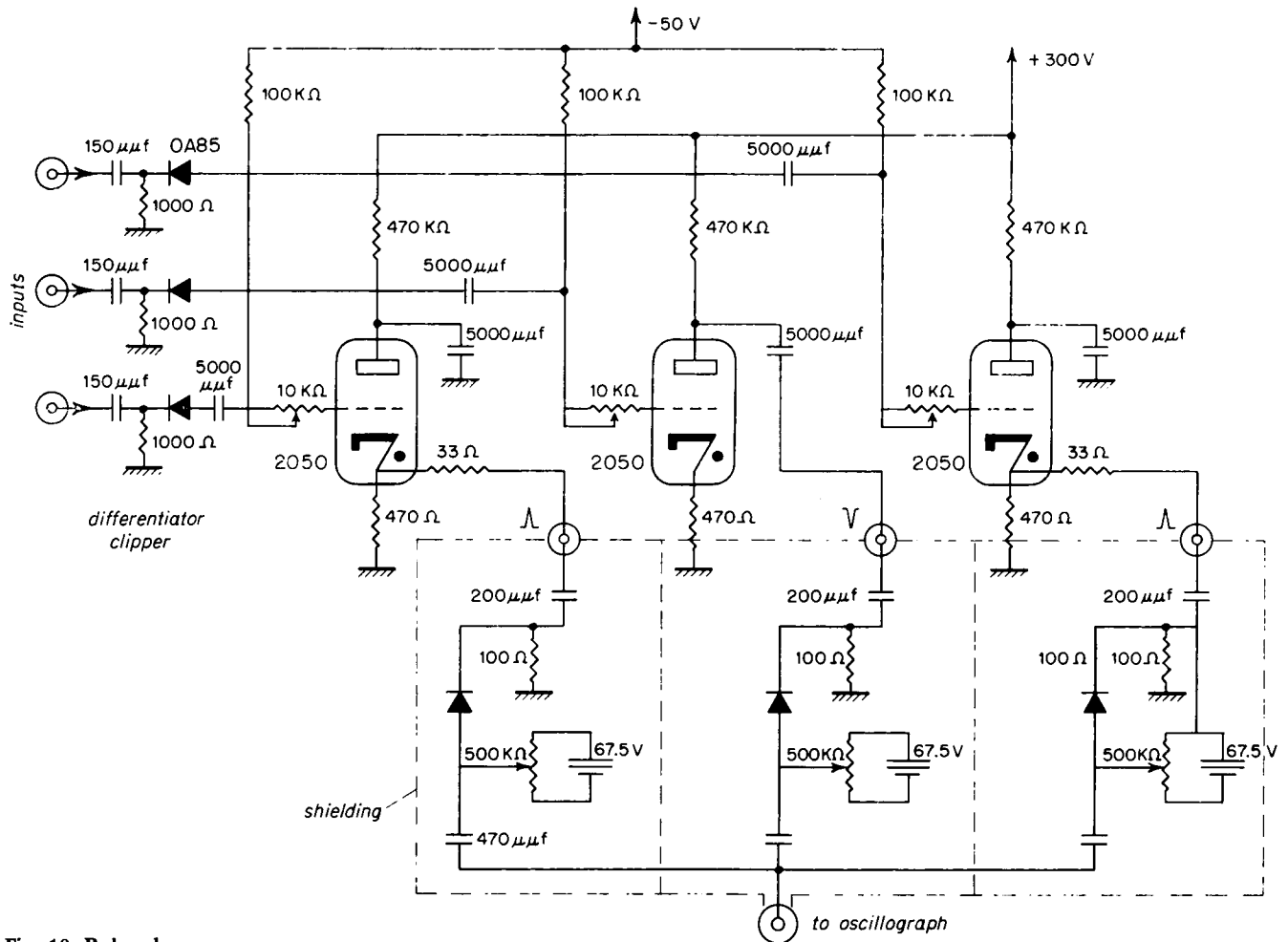

Fig. 10. Pulse shaper.

Delay Circuit

The square wave mentioned just above connects with a time base which gives a signal in sawtooth form of which the linear part, of a duration of 50 μsec, has an amplitude of 280 v. This signal is connected with a d-c clamp diode with adjustable plate voltage, the latter being regulated by means of a set of resistors acting as delay selectors. A change of 7.5 v causes a delay of 1 μsec.

After the pulse has been delayed in the manner described and has passed through a two-stage amplifier, it is differentiated. The resulting negative pulse with a steep front passes through a 6AQ5 tube acting as a cathode follower and goes to the triggering circuit.

It should be noted that the positive pulse which follows the negative pulse after a few dozen microseconds is absorbed by a diode.

Triggering Circuit

After amplification, the negative pulse is fed to two thyratrons in series, the second of these delivering a pulse of 14 kv which triggers a 600-kv generator.

Chronometry

The three high-voltage shocks cause the emission of x-rays supplying three signal sequences of high-frequency oscillations. They are shaped by differentiation, passage through a clipper and a thyatron. The steep front pulses obtained still contain parasitics and pass once again through a differentiator and an amplitude clipper, and then pass to the input of the oscilloscope.

In order to facilitate the readings, one of the three channels gives a negative pulse, corresponding to the second voltage shock, while the third shock gives a positive pulse of greater amplitude than that of the first shock. See Fig. 11.

The triggering of the oscilloscope sweep may be obtained at will either from the synchronization switch after passage through a flip-flop or from one of the high-voltage shocks.

Measuring Delays

The indicated delays are checked before firing by means of a chronograph (accurate to 1/8 μsec) and after firing on the oscilloscope record. The maximum dispersion is 0.1 μsec.

Laboratory Studies

In parallel with the use of this triple x-ray flash equipment, we studied the influence of the main variables governing a simple x-ray flash photography installation in the laboratory.

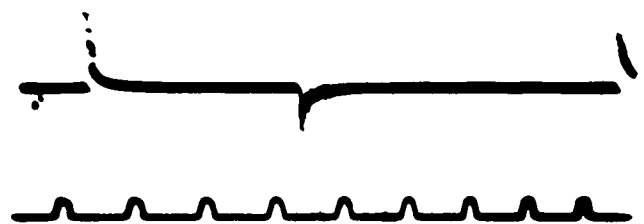

Fig. 11. Oscilloscope for timing of flashes.

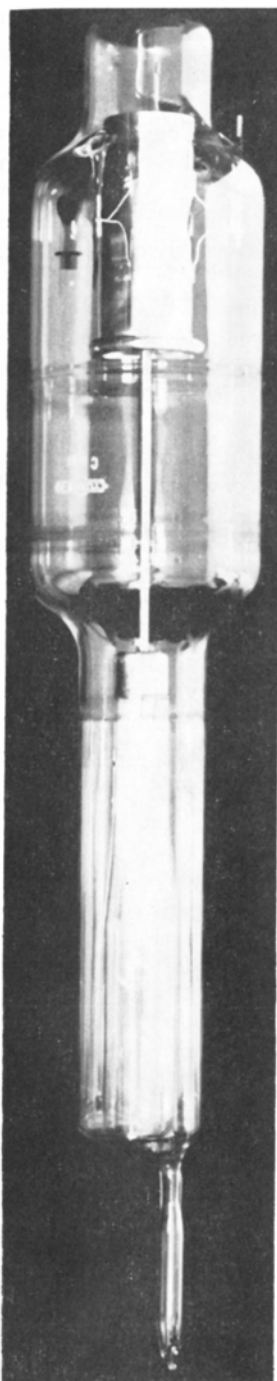

Fig. 12. Standard Tubix tube.

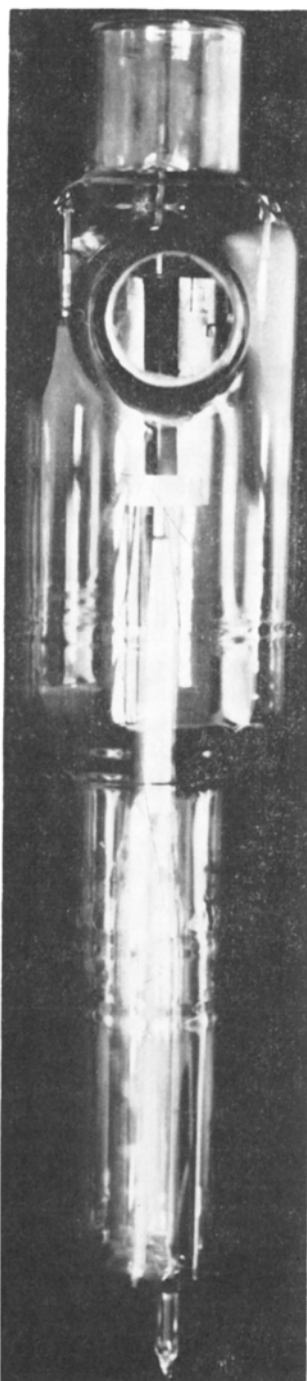

Fig. 13. C.E.A. tube.

The method consists essentially of simultaneous recording of the following values as a function of time: voltage at the tube terminals, intensity of the current within the tube and intensity of x-ray emission — and also by measuring the penetration.

The shock generator used can be changed as required into a generator of 600 kv – 300 joules, 300 kv – 300 joules or even 300 kv – 150 joules.

Four types of tubes were examined: (a) Westinghouse tubes, (b) Standard Tubix tubes (see Fig. 12), (c) Tubix tubes with movable anode and (d) special tubes manufactured at the C.E.A. (see Fig. 13). These tubes would operate either as triodes or as diodes. When a tube was operating as a triode, the effect of the value of the ignition electrode resistance was examined.

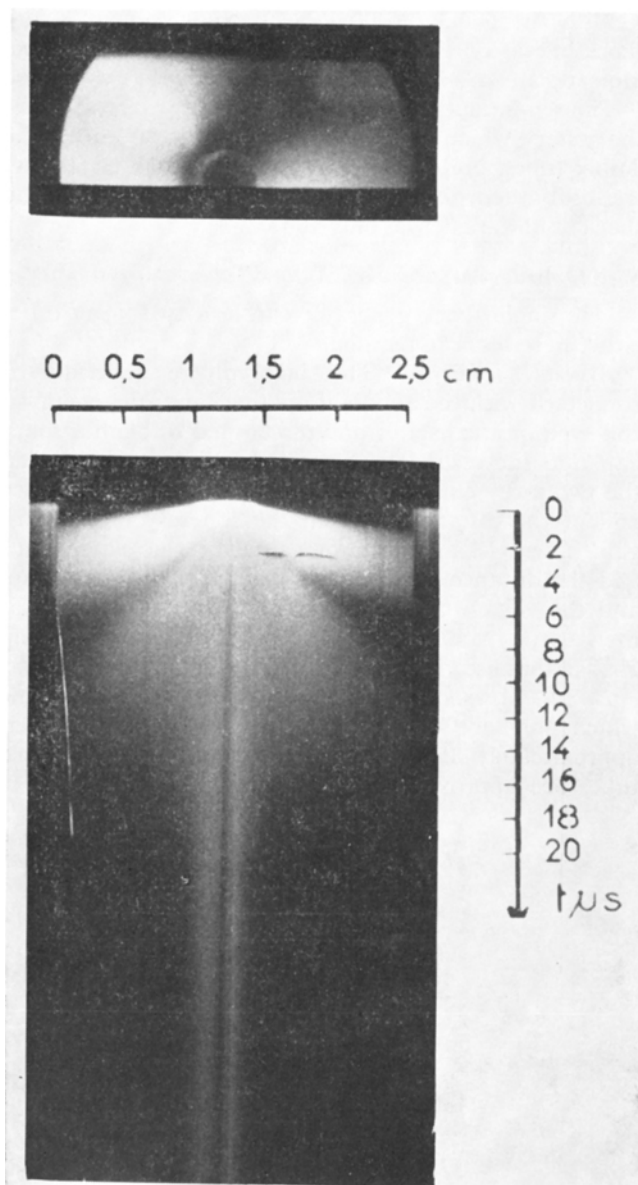

Fig. 14. End view and slit camera record of visible light emitted by x-ray tube.

The conclusions drawn from all the experiments made are the following:

Below 250/300 kv it is preferable to have the tube operate as a triode with an ignition electrode resistance of more than 100 kilo-ohms.

The penetration is defined as the thickness at which, in a step filter, two adjacent steps relating to different thicknesses can just be recognized by their contrast; and experience has shown that penetration increases more rapidly with the voltage than with the energy dissipated. Thus it does not seem practical to use a high capacitance because an increase in voltage is more suitable for greater penetration.

The amplitude of the x-ray emission increases with the voltage, and its maximum duration of 0.5 μ sec is practically a function of the filtering effected by the protective units.

The diameter of the emission center increases with the voltage, and its maximum is the base diameter of the cone which constitutes the anode.

With the 600 kv - 300 joule setting, and an actual shock of 500 kv, the electrometer, at 1 m from the tube, indicates an emission of 30 milliroentgens.

The self-inductance due to the discharge circuit limits the voltage which can be applied to the x-ray tube. The Tubix tubes, built to operate under a shock of 500 kv, were subjected to indicated shocks of 1800 kv while the shock on the anode was only 900 kv.

Special Arrangement of Two X-Ray Tubes

One single shock generator can feed two x-ray tubes either in series or in parallel.

Assembly in Series: The high-voltage generator is connected with the anode of the first tube; the energy is collected in a capacitor and discharged through a spark gap into the second tube. The delay interval between the two x-ray emissions is a function of the capacitance and of the distance between the spheres of the spark gap. There is an optimum value for the capacitance and the distance between the spheres of the spark gap, and the voltage actually applied to the second tube is then at the maximum. It is, at any rate, approximately 20% of that used in the first tube.

Parallel Assembly: There is a critical voltage below which only one of the two tubes functions, and it is approximately 250 kv. The x-ray emissions of the two tubes are approximately equal, and the amplitude of

each is about half as great as that of a single tube fed in the same manner.

Study of Residual Pressure

If an x-ray tube is connected with a pressure gage, it is possible to study the development of the pressure with time.

From an initial pressure of 5.10^{-6} mm Hg, the pressure decreases rapidly to 1.10^{-8} after several shocks of 400 kv, and to 10^{-10} after shocks of 600 kv.

The duration of the x-ray emission undergoes virtually no change for pressures between 1.10^{-6} and 1.10^{-10} and is approximately 0.2 μ sec at midamplitude.

Examination of Visible Light

An examination of the visible light which accompanies an x-ray flash was made by means of a spectrograph and a slit camera and shows the presence of two luminous plasmas which move at high velocity (6 km/sec) toward the cathode. See Fig. 14.

In the first plasma, which has a higher temperature than the second, it was possible to find evidence of the presence of many tungsten lines (arc and spark lines). The low luminosity did not allow even a qualitative analysis of the second plasma. It can be assumed, however, that it is due to ionized atoms which return progressively to the neutral state.