

# standards and recommended practices

## Approved American Standards

Published here for your information are four American Standards approved on February 7, 1966 by the American Standards Association.

PH22.55-1966, Specifications for Leaders and Cue Marks for 35mm and 16mm Sound Motion-Picture Release Prints, is a revision of the 1947 issue. The Universal Leader specified in this standard represents the culmination of many years of effort to design a leader which would satisfy both television and motion-picture requirements.

PH22.73-1966, Dimensions for 35mm Motion-Picture Film, Perforated 32mm, 2R-2994, and PH22.103-1966, Specifications for Projector Usage of 35mm Release Prints with Four-Track Magnetic Sound Records, are both editorial revisions of previous standards to facilitate their use.

PH22.147-1966, Dimensions of Motion-Picture Projection Reels for Combination 70/35mm Projectors is a new standard. Inasmuch as compliance with American Standards is purely

voluntary, these standards will become truly effective if very broad publicity is given to their existence. The ASA and the SMPTE would appreciate any personal influence to promote the use of these standards where such action is appropriate and proper. Copies of the standards may be obtained for a nominal fee from the American Standards Association, 10 East 40th Street, New York City, 10016.—A.E.A.

## Withdrawal of American Standard

On February 21, 1966 the American Standards Association approved the withdrawal of PH22.53-1953, Method of Determining Resolving Power of 16mm Motion-Picture Projector Lenses. The action was taken upon the recommendation of both the SMPTE Standards Committee and the ASA Sectional Committee PH22 because the test pattern specified in the standard has not been in use for many years and, further, the standard did not represent current practice.—A.E.A.

American Standard Specifications for

## Leaders and Cue Marks for 35mm and 16mm Sound Motion-Picture Release Prints



Rev. U.S. Pat. Off.  
PH22.55-1966  
Revision of  
Z22.55-1947  
UDC 778.5

Page 1 of 6 pages

### 1. Scope

This standard specifies the make-up or assembly of leaders and cue marks for 35mm and 16mm sound motion-picture release prints for use in both motion-picture theaters and television studios.

### 2. Reduction Ratio

The reduction ratio in the production of the head and foot leaders from 35mm motion-picture film shall be in accordance with American Standard 16-Millimeter Positive Aperture Dimensions and Image Size for Positive Prints Made from 35-Millimeter Negatives, PH22.46-1946 (Reaffirmed 1959).

### 3. Orientation of Words and Numerals

3.1 Orientation and dimensions of letters and numerals in this standard are with respect to 35mm motion-picture film and are modified proportionally for 16mm prints in accordance with Section 2.

3.2 The third, fourth, and fifth frames of the identification sections containing the title of the film and reel number shall be printed in white letters on a black background so that they are read normally when the reel is uppermost and the leading end or head of the film hangs down ready for threading.

3.3 The words "Type of Sound," "Aspect Ratio," "Picture Title," "Company," "Series," "Reel No.," "Prod. No.," and "Play Date" shall be printed lengthwise with the film in white letters on a black background.

3.4 In sections where information is to be printed lengthwise with the film, light framelines shall be included and all such printing must be placed within the outlined areas so that it can be read on 16mm reduction prints.

3.5 In the trailer (foot leader), the title of the film and the reel number shall be printed so that they appear inverted when the remainder of the reel is uppermost and the film hangs downward as in projection.

### 4. Head Leader (See Fig. 1)

4.1 Protective Section. The protective section of the 35mm leader shall consist of 8 feet of transparent or raw stock; for 16mm leader, 3 3/4 feet. When the protective leader has been reduced to a length of 6 feet for 35mm film or 2 1/2 feet for 16mm film, it is to be restored to its original length.

The last frame of this section contains the words "Splice Here" and an arrow pointing to the frameline between this frame and frame 1 of the identification section. The letters should be at least 1/8 inch high.

Approved February 7, 1966, by the American Standards Association, Incorporated  
Sponsor: Society of Motion Picture and Television Engineers, Inc.

International Classification

Printed in U.S.A.  
SMA 1024

Copyright 1966 by the American Standards Association, Incorporated  
10 East 40th Street, New York, N. Y. 10016

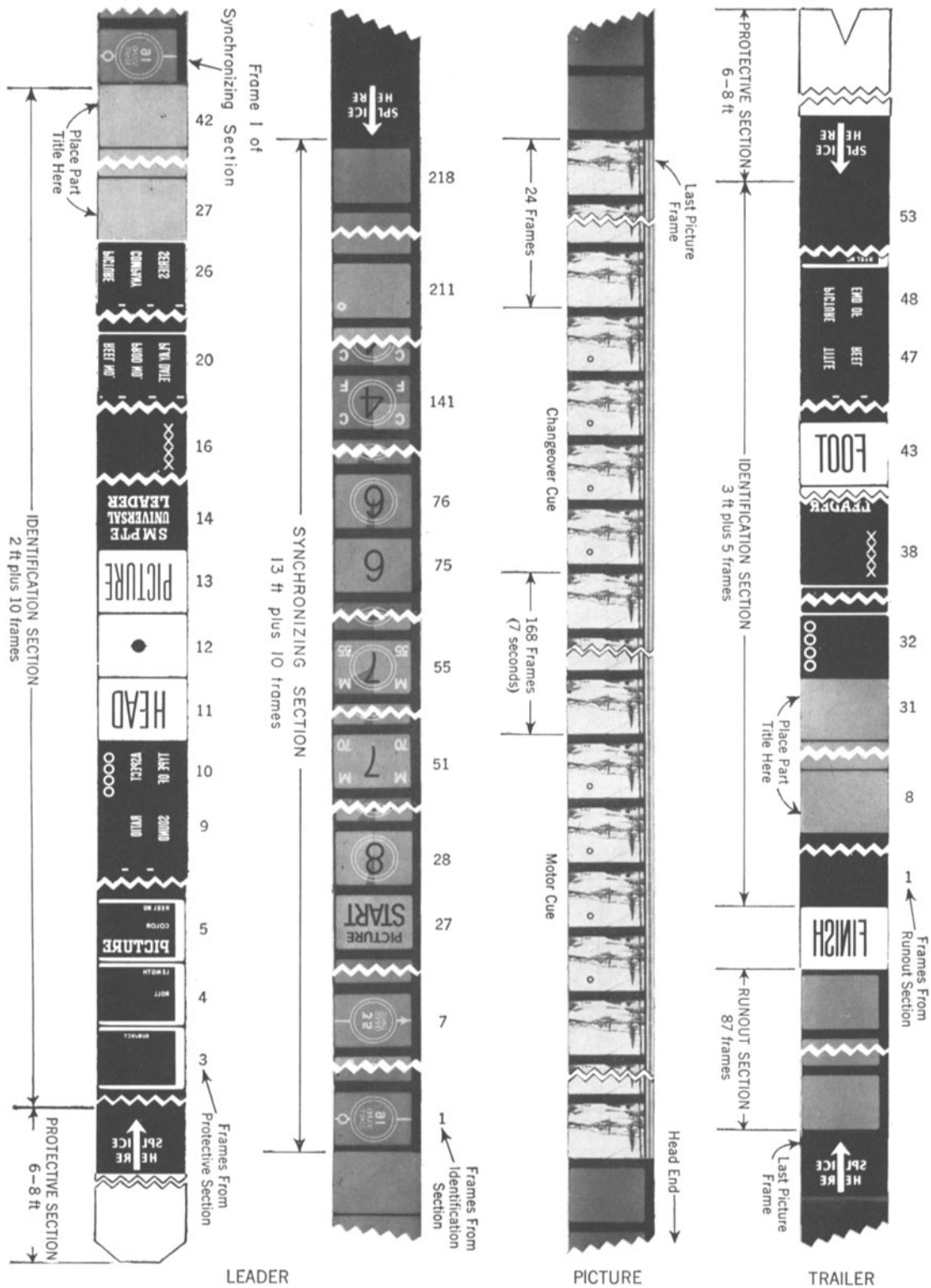

Fig. 1. Figure shows 35mm film with sound track on right edge as seen from the light source in the projector. The sound track is on the left edge of 16mm film.

PH22.55-1966

**4.2 Identification Section.** The identification section of the leader shall be 42 frames in length. The frames may be of the 4 x 3 format or of a reduced height.

**4.2.1** Since many types of film may be used for leaders, exact densities have not been specified. For the purpose of this standard, the following approximate densities are suggested:

White or low density	0.35
Gray or medium density	0.65
Black or high density	1.95

**4.2.2** The identification section, when viewed as specified in 3.2, shall be made up as follows:

Frames 1-2—Black.

Frame 3—The printed word "Subject" with letters  $\frac{1}{16}$  inch high at top of frame in upright position, white on black background (4 x 3 format).

Frame 4—The printed word "Length" at top left side of frame and the printed word "Roll" at center of frame on left side. Lettering to be comparable to that in Frame 3 (4 x 3 format).

Frame 5—The printed words "Reel No." at top left side of frame and printed word "Color" at center of frame on left side. Lettering, read upright, to be comparable to that in Frame 3. At bottom of frame printed word "Picture"  $\frac{1}{8}$  inch high.

Frames 6-10—Five frames of black with light framelines on which the words "Aspect Ratio" and "Type of Sound" are plainly printed lengthwise with the film in  $\frac{1}{8}$  inch high white letters. Each group of words starting in the 10th frame and in two separate lengthwise lines reading through base of film from left to right with head end of film at right.

Frame 10—Four letter O's vertically in line and opposite the sound track area approximately  $\frac{3}{16}$  inch from the 35mm camera aperture centerline opposite the sound area. Letters to be  $\frac{1}{8}$  inch high and  $\frac{1}{8}$  inch wide, white on black background (4 x 3 format).

Frame 11—The printed word "Head" not less than  $\frac{3}{8}$  inch high in inverted black letters on white or low-density background.

Frame 12—A  $\frac{1}{8}$ -inch diameter black dot in center of 4 x 3 format. White or low-density background with narrow black framelines.

Frame 13—The printed word "Picture" not less than  $\frac{3}{8}$  inch high in inverted black letters on white or low-density background.

Frames 14-15—Two frames in which the words "SMPTE Universal Leader" shall be printed. Letters to be not less than  $\frac{1}{8}$  inch high. Inverted white letters on a black background (4 x 3 format).

Frame 16—Four letter X's vertically in line adjacent to sound track area approximately  $\frac{3}{16}$  inch from the 35mm camera aperture centerline toward sound area. Letters to be  $\frac{1}{8}$  inch high and  $\frac{1}{8}$  inch wide, white in black background (4 x 3 format).

Frames 17-18—Same as Frames 14-15.

Frames 19-26—Eight frames of black with light framelines on which the words "Reel No.," "Prod. No.," and "Play Date" are printed lengthwise with the film in  $\frac{1}{8}$  inch high white letters in Frame 20. In Frame 26, on three lines lengthwise, reading left to right through film base with head of leader to right, the words "Picture," "Company," and "Series," using the same format as that in Frame 20.

Frames 27-42—Sixteen frames of part titles are to be inserted here. In each frame (1) the reel number (Arabic numeral not less than  $\frac{1}{4}$  of frame height) and (2) the picture title shall be printed in black letters on a white background. If part titles are not available, these frames should be black of medium density with narrow framelines.

**4.3 Synchronizing Section.** The synchronizing section of the leader shall be 218 frames in length.

**4.3.1** The cross-hair lines shall be black and the two large circles shall be white. Seconds count-down numerals shall project right side up.

**4.3.2** The synchronizing section, when viewed as specified in 3.2, shall be made up as follows:

Frame 1—The 16mm sound start indication shall be printed in white letters on a medium-density background as shown in Fig. 2.

Frames 2-6—Five frames of medium density.

Frame 7—The 35mm sound start indication shall be printed in white letters on a medium-density background as shown in Fig. 3.

Frames 8-26—Nineteen frames of medium density.

Frame 27—The words "Picture Start" shall be printed in black on a low-density background, the letters in the word "Picture" to be not less than  $\frac{1}{8}$  inch high and in "Start" not less than  $\frac{1}{4}$  inch high. Visual count-down begins with this frame.

Frame 28—The visual count-down continues with the figure "8" in black within a circle of low density on an over-all low-density background with a 15-degree wedge of medium density on the right of top center, as projected. In each succeeding frame, the wedge increases in 15-degree steps, moving clockwise when projected. See Fig. 4.

Frame 50—All background, except for a 15-degree wedge at the top left center, is of medium density.

Frame 51—The numeral changes to "7" in black on a low-density background. On each side of the "7," there shall be in letters  $\frac{1}{8}$  inch high, white on a low-density background, "M" and "70" vertically to indicate 70mm magnetic sound start.

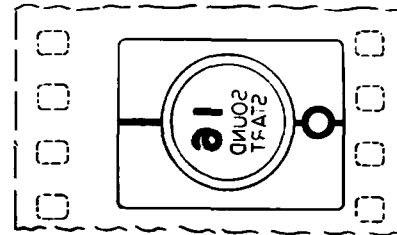

Fig. 2. 16mm Sound Start Identification Frame.  
NOTE: Section within frame lines as seen when projected.

Frame 52—The wedge again appears.

Frame 55—The white "M35" appears in the same format as the "M70" appears in Frame 51. See Fig. 5.

Frames 56-140—The sequence of numerals marking the seconds of film running time at 24 fps (frames per second) continues to Frame 140.

Frames 141-146—The moving wedge and numeral appear on Frames 141-146 but with the addition of the Gothic letters "C" and "P" on the left- and right-hand side of the circle, respectively, to indicate the position in the leader where one to six frames may be removed and a similar number of control frames spliced in.

Frames 147-170—The sequence of numerals and moving wedge marking the seconds of film running time continues through to Frame 170.

Frame 171—The numeral "2" in black on a low-density background appears ending the visual count-down.

Frames 172-210—Thirty-nine frames of diffuse density 1.0 to 1.2 maximum.

Frame 211—A single transparent dot shall be located as specified in 5.2.

Frames 212-218—Seven frames of diffuse density 1.0 to 1.2 maximum.

**4.3.3** One additional frame follows with the words "Splice Here" and an arrow pointing to the frameline between Frame 218 and this frame. The letters should be at least  $\frac{1}{8}$  inch high.

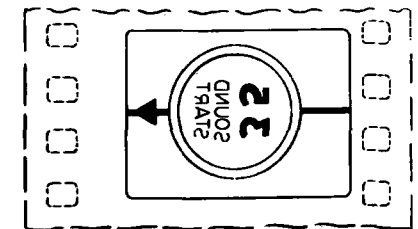

Fig. 3. 35mm Sound Start Identification Frame.  
NOTE: Section within frame lines as seen when projected.

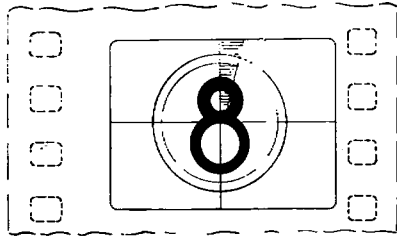

Fig. 4. Example of Visual Count-down.

NOTE: Section within frame lines as seen when projected.

### 5. Picture Section (See Fig. 1)

**5.1 Picture.** It is recommended that picture action start and finish on fades wherever possible. Otherwise, significant sound should be kept at least five feet for 35mm prints and two feet for 16mm prints from the start and finish of the picture.

**5.2 Motor Cue.** The motor cue shall consist of an opaque circular dot with a transparent outline or a transparent circular dot with an opaque outline, printed from a 35mm negative which has had four consecutive frames punched with a die 0.094 inch in diameter. The position of this cue mark for release prints with aspect ratios up to 1.85:1 shall be as shown in Fig. 6. The position of the cue mark for release prints with aspect ratios from 2.35:1 to 2:1 shall be as shown in Fig. 7.

Following the four frames containing the motor cue, there shall be 168 frames, or seven seconds running time, to the beginning of the changeover cue.

**5.3 Changeover Cue.** The changeover cue shall consist of four frames containing circular dots of the same dimensions and position on the frame as those in the motor cue.

Following the four frames of the changeover cue, there shall be 24 frames, or one second running time, to the beginning of the runout section of the trailer.

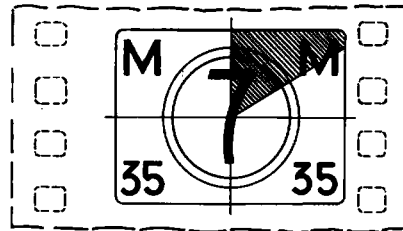

Fig. 5. 35mm Magnetic Sound Start.

NOTE: Section within frame lines as seen when projected.

### 6. Trailer (Foot Leader) (See Fig. 1)

**6.1 Additional Frame.** One additional frame follows with the words "Splice Here" and an arrow pointing to the frameline between the picture section and the trailer. The letters should be at least 1/8 inch high.

**6.2 Runout Section.** The runout section of the trailer shall consist of 88 frames, 87 of which are to be of diffuse density 1.0 to 1.2 maximum. Frame 88 shall have the printed word "Finish" not less than 3/8 inch high in upright black letters on white or low-density background.

**6.3 Identification Section.** The identification section of the trailer shall consist of 53 frames.

**6.3.1** The identification section shall be made up as follows:

Frames 1-7—Seven frames of black opaque without framelines.

Frames 8-31—Twenty-four frames of part titles are to be inserted here. In each frame (1) the end of reel, (2) the reel number (Arabic numeral not less than 1/4 of frame height), and (3) the picture title shall be printed in black letters on a white background. If part titles are not available, these frames shall be blank of medium density with narrow framelines.

Frame 32—Four letter O's vertically in line and opposite the sound track area approximately 3/8 inch from the 35mm camera aperture centerline opposite the sound area. Letters to be 1/8 inch high and 1/8 inch wide, white on black background (4 x 3 format).

PH22.55-1966

Frames 33-37—Five opaque frames with light framelines for reproduction of information written on the negative.

Frame 38—Opaque with four X's adjacent to the sound track, similar to Frame 16 of the head leader identification section.

Frames 39-40—Similar to Frames 14-15 of head leader identification section with words "SMPTE Universal Leader," except that the words are upright.

Frame 41—Similar to Frame 13 of head leader identification section, except that the word "Picture" is upright (not inverted).

Frame 42—Dot similar to that in Frame 12 of head leader identification section.

Frame 43—Similar to Frame 11 of head leader identification section, except printed word is "Foot" which is upright (not inverted).

Frames 44-48—Five blank frames of opaque with light framelines upon which the words (1) "Picture Title" and (2) "End of Reel" are printed

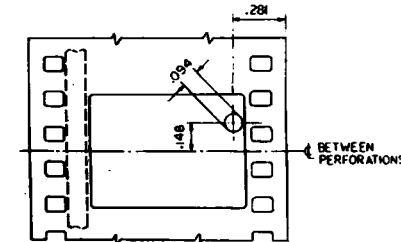

Fig. 6. Position of Cue Marks for Release Prints with Aspect Ratios up to 1.85:1.

NOTE: Image as seen on the screen.

lengthwise with the film in 1/8 inch high white letters on black background.

Frames 49-51—Three frames identical to Frames 5, 4, and 3, respectively, of head leader identification section, except that the letters are inverted.

Frames 52-53—Two black frames.

**6.3.2** One additional frame follows with the words "Splice Here" and an arrow pointing to the frameline between this frame and Frame 53 to indicate where the protective section joins the trailer.

**6.4 Protective Section.** The protective section of the trailer shall consist of 8 feet of transparent or raw stock for 35mm prints and 3/4 feet for 16mm prints.

NOTE: The Society of Motion Picture and Television Engineers makes available leaders in accordance with this standard. Supplied on master positive motion-picture stock in 16mm and 35mm sizes, intended for reproduction as negatives, they are identified as SMPTE Universal Leaders.

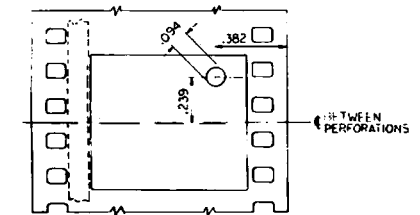

Fig. 7. Position of Cue Marks for Release Prints with Aspect Ratios from 2.35:1 to 2:1.

NOTE: Image as seen on the screen.

### Appendix

(This Appendix is not a part of American Standard Specifications for Release Prints, PH22.55-1966, but is included to facilitate its use.)

**A1.** The difference between projection rates of 24 and 25 frames per second is negligible in the normal usage of the leader.

**A2.** Logos, trademarks, or other extraneous material, if absolutely necessary, should be inserted in the leader prior to the 16mm sound start cue or just preceding Frame 32 of the trailer identification section or both.

**A3.** The outside diameter of the large white circle indicates the height of the television safe action area specified in SMPTE Recommended Practice RP 13-1963, Safe Action Area for TV Transmission, Society of Motion Picture and Television Engineers.

**A4.** The outside diameter of the small white circle is equivalent to the height of a projector aperture having an aspect ratio of 1.85:1.

PH22.55-1966

American Standard Specifications for  
**Projector Usage of 35mm Release Prints  
 with Four-Track Magnetic Sound Records**

ASA  
 Reg. U.S. Pat. Off.  
**PH22.103-1966**  
 Revision of  
 PH22.103-1957  
 \*UDC 778.554.45:771.531.551.2

### 1. Scope

This standard specifies the location of the photographic emulsion and magnetic striping relative to the projector light source and lens, the rate of projection and the relationship between sound and picture of 35mm sound motion-picture film having a 0.073 x 0.078-in. perforation (as specified in American Standard Dimensions for 35mm Motion-Picture Film, CS-1870, PH22.102-1964).

### 2. Position of Photographic Emulsion and Magnetic Striping

2.1 The photographic emulsion shall be on the side of the film which faces toward the light source of the projector.

2.2 The magnetic striping shall be on the side of the film which faces toward the lens of the projector.

### 3. Rate of Projection

The rate of projection shall be 24 frames/sec.

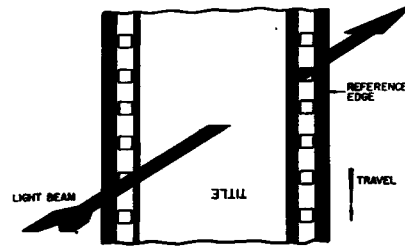

Film as seen from the light source  
 in the projector

### 4. Relationship Between Sound and Picture

When the sound records are reproduced, the distance from the sound-scanning point to the center of the projector aperture shall be adjusted to bring the picture and sound into synchronism for the average observer. Since sound travels at a rate of about 1100 ft per second (approximately 50 ft in 1/24 second), the sound can be adjusted by advancing the sound record in the projector one frame for every 50 ft from the average observer. (The location and dimensions of the magnetic sound records shall be as specified in American Standard Dimensions of Four-Track Magnetic Sound Records for 35mm Release Prints, PH22.137-1963).

American Standard Dimensions for  
**35mm Motion-Picture Film,  
 Perforated 32mm, 2R-2994**

ASA  
 Reg. U.S. Pat. Off.  
**PH22.73-1966**  
 Revision of  
 PH22.73-1958  
 \*UDC 778.5

Page 1 of 3 pages

### 1. Scope

This standard specifies the cutting and perforating dimensions for 35mm motion-picture film having two rows of 16mm type perforations, one row near each edge of the 35mm film, and a perforation pitch of 0.2994 in.

### 2. Dimensions

2.1 The dimensions shall be as given in the figure and table.

2.2 These dimensions pertain to a safety film as defined in Appendix A5.

2.3 These dimensions apply to material immediately after cutting and perforating.

2.4 Dimension L represents the length of any 100 consecutive perforation pitch intervals.

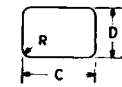
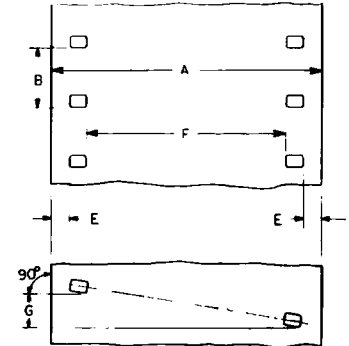

Dimensions		Inches	Millimeters
A	Film width	1.377 ± 0.001	34.98 ± 0.03
B	Perforation pitch	0.2994 ± 0.0005	7.605 ± 0.013
C	Perforation width	0.0720 ± 0.0004	1.829 ± 0.010
D	Perforation height	0.0500 ± 0.0004	1.270 ± 0.010
E	Edge to perforation	0.096 ± 0.002	2.44 ± 0.05
F	Width between perforations	1.041 ± 0.002	26.44 ± 0.05
G	Perforation skewness	0.001	max 0.03
L	100 consecutive perforation pitch intervals	29.94 ± 0.03	760.5 ± 0.8
R	Radius of perforation fillet	0.010 ± 0.001	0.25 ± 0.03

NOTE 1: The title of this standard was established by the application of a nomenclature system developed for all film dimension standards. Each title provides an indication of the film width, a code designation for the perforation shape (BH, KS, DH, or CS) or the number of rows of perforations (1R, 2R or 4R), depending upon

which is the significant factor, and the perforation pitch without the decimal point.

NOTE 2: The metric values in the table of dimensions are converted from the inch values in accordance with conversion principles outlined in American Standard Practice for Inch-Millimeter Conversion for Industrial Use, B48.1-1933 (Reaffirmed 1947).

Approved February 7, 1966, by the American Standards Association, Incorporated  
 Sponsor: Society of Motion Picture and Television Engineers, Inc.

\*Universal Decimal Classification

Copyright 1966 by the American Standards Association, Incorporated  
 10 East 40th Street, New York, N. Y. 10016

Printed in USA  
 ASA1M366

Approved February 7, 1966, by the American Standards Association, Incorporated  
 Sponsor: Society of Motion Picture and Television Engineers, Inc.

\*Universal Decimal Classification

Copyright 1966 by the American Standards Association, Incorporated  
 10 East 40th Street, New York, N. Y. 10016

Printed in USA  
 ASA1M366

## Appendix

(This Appendix is not a part of American Standard Dimensions for 35mm Motion-Picture Film, Perforated 32mm, 2R-2994, PH22.73-1966, but is included to facilitate its use.)

**A1.** The dimensions given in this standard represent the practice of film manufacturers in that the dimensions and tolerances are for film stock immediately after perforation. The punches and dies themselves are made to tolerances considerably smaller than those given, but since film is a plastic material the dimensions of the slit and perforated film stock never agree exactly with the dimensions of the slitters, punches and dies. Film can shrink or swell due to loss or gain in moisture content or can shrink due to loss of solvent. These changes invariably result in changes in the dimensions during the life of the film. The change is generally uniform throughout a roll.

**A2.** It will be noted that among the various standards for slitting and perforating film stock there are often two standards which seem much alike in wording. The difference lies in the longitudinal pitch which is either 0.2994 in. or 0.3000 in. In general, the longer pitch is for print stock and the shorter pitch is for negative stock.

The choice of pitch for negative motion-picture films depends, within certain limits, on the type of printer to be used. Where step-printers are used, and the film is stationary when exposed, the choice of pitch is not strictly limited. Where the film moves continuously over a cylindrical surface at time of printing (sprocket-type printer), there are three major considerations involved in choosing the pitch. These considerations are: (1) the sprocket diameter, (2) the film thickness, (3) the film shrinkage and the rate at which shrinkage occurs.

Maximum steadiness and definition are secured on a sprocket-type printer when the negative stock is somewhat shorter in pitch than the positive stock in the approximate proportion of the thickness of the film to the radius of curvature. For printing on a 40-tooth 32mm sprocket (circumference of about 12 in.) with film 0.0055 to 0.0065 in. thick, the optimum pitch differential is 0.3 percent. The use of the ideal pitch differential for the negative would minimize slippage between the positive stock and negative during the printing operation, thus reducing the amount of blurring and jumping of horizontal lines in the picture or sound image. (This error is to be differentiated from the jump caused by nonuniformity of successive pitches, Dimension B.)

Experience has shown that the average pitch of the negative can vary  $\pm 0.1$  percent from the ideal pitch, which is 0.3 percent shorter than the positive stock, without blurring of picture and sound image being easily detected.

For many years this desired difference in pitch was caused by the shrinkage of the negative film during processing and aging. Current film bases shrink less than the earlier ones and hence a shorter initial pitch becomes desirable. To satisfy this requirement for picture- or sound-negatives, it is common manufacturing practice to aim for a pitch value 0.2 percent shorter than the positive stock onto which they will be printed. The additional shrinkage that occurs during processing and the aging that takes place before the release prints are made then bring the pitch differential close to the optimum and desired value of 0.3 percent. Accordingly, the pitch chosen for the negative stock is 0.2994 in.

Low-shrink negative film perforated to these dimensions should not thereafter shrink appreciably more than 0.2 percent under normal use conditions, and for a reasonable life span, so that the optimum pitch differential from the positive stock of  $0.3 \pm 0.1$  percent is maintained. (The film should be measured after equilibration with air at 70 F and 55 percent relative humidity or at the conditions prevailing at the time of perforating.)

**A3.** The uniformity of pitch, hole size, and margin (Dimensions B, C, D, and E) is an important variable affecting steadiness. Variations in these dimensions, from roll to roll, are of little significance compared to variations from one sprocket hole to the next. Actually it is the maximum variation from one sprocket hole to the next within any small group of consecutive perforations that is important.

**A4.** This kind of film is made on 35mm stock so that it may be processed on 35mm sprocketless developing machines. It is designed for use in intermediate stages in the making of 16mm prints. This standard is based on the values adapted to "low-shrink" film base since nearly all films now manufactured in the U.S. meet the definition noted below.

For the purpose of choice of width, low-shrinkage film base is film base which when coated with emulsion and any other normal coating treatment, perforated, kept in the manufacturer's normal commercial packings for six months at 65 to 75 F, exposed, processed and stored exposed to air for a period not to exceed 30 days at 65 to 75 F and 50 to 60 percent relative humidity, and measured under like conditions of temperature and humidity, shall have shrunk not more than 0.2 percent from its original dimension at the time of perforating.

This definition of low-shrinkage film stock has been found by experience to be useful as a guide to film manufacturers in slitting their stock. Departure from this definition shall not be cause for rejection of the stock. Note that this definition of shrinkage differs from the criterion applying to the choice of longitudinal pitch, where greater periods of time are involved and where short-time tests can be deceptive.

Allowance has been made in arriving at these values for the common tendency of film to expand when ex-

posed to high relative humidity. Allowance should be made for this factor in equipment design and in no case should 16mm equipment fail to accommodate a film of 0.630-in. width.

**A5.** It should be noted that it has been a firm policy of film manufacturers in the U.S. to coat film of 8mm and 16mm width on safety base (see American Standard Specifications for Safety Photographic Film, PH1.25-1965). Films of larger size which ultimately become 8mm and 16mm are naturally covered by the same concept.

# American Standard Dimensions of Motion-Picture Projection Reels for Combination 70/35mm Projectors

ASA  
Reg. U.S. Pat. Off.  
PH22.147-1966  
\*UDC 778.55/.553

Page 1 of 2 pages

## 1. Scope

1.1 This standard specifies the dimensions of 35mm and 70mm motion-picture projection reels intended for use on combination 70/35mm projectors and rewinds.

1.2 This standard does not apply to shipping reels.

## 2. Dimensions

2.1 The dimensions of the reels shall be as given in the figures and table.

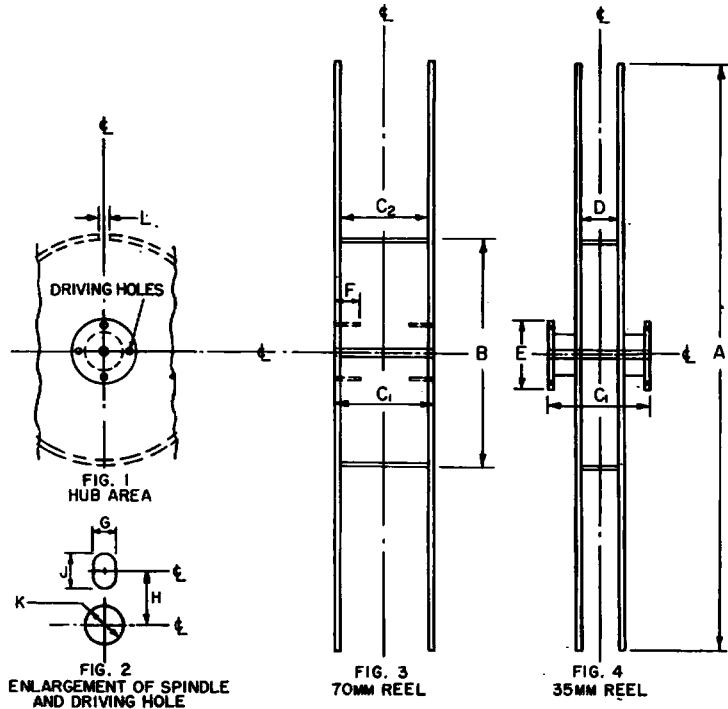

Dimensions	Inches	Millimeters
A (4000-ft capacity)	21.75 ± 0.03	552.4 ± 0.8
A (2700-ft capacity)	16.87 ± 0.03	428.5 ± 0.8
B (4000-ft capacity)	8.00 ± 0.03	203.2 ± 0.8
B (2700-ft capacity)	5.00 ± 0.03	127.0 ± 0.8
C <sub>1</sub>	3.41 ± 0.03	86.6 ± 0.8
C <sub>2</sub>	2.87 ± 0.03	72.9 ± 0.8
D	1.50 + 0.00 - 0.03	38.1 + 0.0 - 0.8
E	2.50 min	63.5 min
F	0.75 min	19.0 min
G	0.265 ± 0.002	6.73 ± 0.05
H	0.782 nom	19.86 nom
J	0.375 nom	9.52 nom
K (Diameter)	0.505 ± 0.002	12.83 ± 0.05
L (Threading slot)	0.035 nom	0.89 nom

2.2 Fig. 2 indicates the location and size of the spindle hole and the four driving holes. These appear on both flanges.

2.3 Dimension F in Fig. 3 indicates a clearance for the driving pin, and shall be a minimum of 0.75 inch (19.0mm).

2.4 The reels are intended to be used on spindles whose diameter is 0.5000<sup>+0.0000</sup>/<sub>-0.0008</sub> inch (12.700<sup>+0.0000</sup>/<sub>-0.020</sub> mm) and to be driven by a drive pin of 0.250 inch (6.35mm) nominal diameter, engaging in one of the four driving holes.

2.5 The centerlines indicated for Figs. 3 and 4 are coincident.

## Appendix

(This Appendix is not a part of American Standard Dimensions of Motion-Picture Projection Reels for Combination 70/35mm Projectors PH22.147-1966, but is included to facilitate its use.)

A1. The specifications for the reels are based upon good engineering design of film winding and of a minimum tension change between hub and periphery. Complete interchangeability, however, may require some adjustment in the take-up and hold-back tensions of the projector when changing between 70mm and 35mm films.

A2. In designing reels of the size and weight described in this standard, it is the practice to chamfer the spindle hole to facilitate placing the reel on the spindle. The degree of chamfer should be in accordance with good engineering practice, and should not reduce the bearing surface of the spindle hole on the spindle to the point of endangering reel stability.

Approved February 7, 1966, by the American Standards Association, Incorporated  
Sponsor: Society of Motion Picture and Television Engineers, Inc.

\*Universal Decimal Classification