

the Star Theater in Westbrook. As he tells above, in 1918 he joined the staff of the DeLuxe Strand Theater in Portland (as Head Usher). In 1921, following his appearance at the Strand as a saxophonist, he entered the University of Maine (remember the Maine Stein Song?) and the next year transferred to Yale. The rest, as they say, is history.

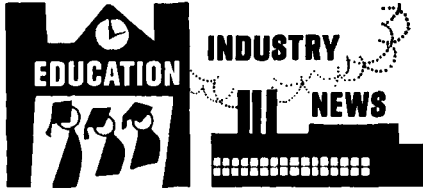

Frederick M. Remley, Jr., is the SMPTE appointee to the post of Chairman of the American National Standards Committee C98 on Combined Visual-Aural Magnetic

### SMPTE Exhibit Award



Wilton R. Holm, SMPTE Executive Vice-President, presents the SMPTE Exhibit Award plaque to Patrick Byrne of Kliegl Bros. Western Corp.

Recording for Television. The Committee operates under the American National Standards Institute. Mr. Remley succeeds Frank N. Gillette who held the post for more than eight years.

Mr. Remley is Technical Director of Broadcasting Service at the University of Michigan which includes radio stations WUOM and WVGR as well as the Television Center. For the last four years, he has been Chairman of the Society's Video-Tape Recording Committee, the preparatory group for American National C98 Standards. His work in the field of standardization is internationally recognized and he

Kliegl Bros. Western Corp., 4726 Melrose Ave., Los Angeles, CA 90029, is the recipient of the SMPTE 106th Conference Exhibit Award. The award-winning display of TV lighting equipments included a new 10-in Fresnel and focusing scoop, the Lilliput Twin using 5000-K daylight lamps, a multiscene control console and several other units. The Kliegl Bros. display competed with a field of more than 50 exhibitors. Displays were judged by a special committee on the basis of effectiveness, originality and overall interest.

SMPTE Executive Vice-President Wilton R. Holm presented the award, consisting of an engraved plaque, to Patrick Byrne as the representative of Kliegl Bros. Presentation ceremonies took place in Mr. Holm's office at the Association of Motion Picture and Television Producers where he is Executive Director of the AMPTP Research Center.

has been a United States delegate to CCIR (International Radio Consultative Committee) meetings held in Vienna in 1965 and in Oslo in 1966. At present he is Chairman of the United States Preparatory Committee of CCIR, Subgroup X-A on Television Standards

He is a Fellow of the Society. From 1963 through 1967 he was Manager of the Detroit Section and he was Topic Chairman of the Color Television Broadcasting Conference held in Detroit in January 1967.

At the University of Michigan he contributed to the design and construction of

# ZOOMAR

## 4-in-1

### TELE-COMBINATION

Model "FEKOM"

### 4 Focal Lengths in 1 Package

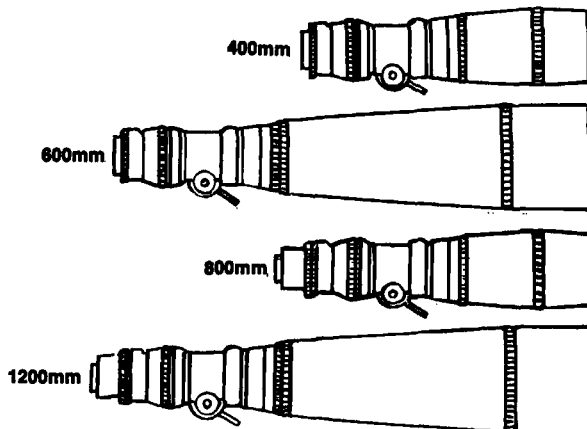

## ZOOMAR, INC.

55 Sea Cliff Avenue, Glen Cove, L. I., New York 11542 516/878-1901, 1904  
 IN CALIFORNIA:  
 6725 Sunset Boulevard, Hollywood, California 90028 213/465-2789



The new Zoomar Tele-Combination consists of:

- 1) A basic 400mm telephoto lens in focusing mount.
- 2) A 600mm interchangeable front which can replace the 400mm unit in the focusing mount.
- 3) A specially designed 2X range extender which converts the 400 into 800mm, and the 600 into 1200mm focal lengths. One adapter of your choice for a 35mm M.P. or 16mm "C" mount camera.
- 4) Handsome, compact, padded carrying case with double locks.