

Maison de Radio-Canada

When the SMPTE met in Montreal in October 1971 the Maison de Radio-Canada project was well along in construction and beginning equipping. The overall project has been described by N. R. Grover and E. E. Sidney in "Maison de Radio-Canada Project," Jour. SMPTE; 81:773-783, Oct. 1972. Two major facilities of the broadcast center are now described in the following papers.

Television Technical Facilities at Maison de Radio-Canada By B. D. BALDRY, G. A. BYRNE and R. SAVARD

Integrated circuit techniques and a systems approach are making it possible to centralize equipment and facilities at Maison de Radio-Canada and to permit them to be assigned as needed. Such centralizing is desirable to meet the timing requirements of color TV, but it requires remote control of switching, delegation, machine control, etc. Particular attention is given to a Program Routing Switcher (which routes program audio and video from source to distribution) and a Control Assignment Switcher (which handles the point-to-point assignment of intercom, pulses, and remote machine control). A minicomputer is employed to control the Program Routing Switcher and perform code translations and validity checks; provision has been made to computerize the Control Assignment Switch also. Other systems and subsystems treated include studio vision mixers, TV audio consoles, the TV intercom system, live camera channels, and VTR and telecine chains.

FROM THE OUTSET, the design has been conceived to centralize equipment where possible with machine assignments as needed. With the advent of color and all its critical timing requirements, centralizing as much equipment as possible became even more desirable. This brought with it problems however, of remote control of switching, delegation, machine control, etc., and it was not until the introduction of solid-state integrated circuit techniques that the system approach adopted became fully realizable in an economic and practical manner.

The TV routing system may be considered in two parts: the first, the Program Switcher concerned with routing the program audio and video from source to distribution; and the second, the Control Assignment Switcher with assignment of intercom, pulses and remote machine control between the same two points, as required. The philosophy behind the operation of the TV routing system is that any receiving point of a signal, be it a monitor, a VTR (videotape recorder), or a Vision Mixer input can itself select and use both audio and video of the chosen source. However, the control of machine functions (start, stop, etc.) and analog functions (gain, lift, etc.) can only be assigned from one central position, i.e., Master Control.

The Program Routing Switcher takes the form of a large matrix of 52 inputs (expandable in the future to 78 inputs) feeding 112 outputs (expandable in the future to 189 outputs). Figure 1 is a

schematic depiction of the present and future system.

The inputs consist of studio outputs, telecines, VTRs, booth outputs, input bays, test signals and miscellaneous sources such as slow-motion video recorders, Divcon units, off-air tuners, jackfield entry and an emergency slide scanner. The outputs feed a Master Control monitoring position, the videotape recording room, cue monitors in each studio and telecine area and six preselectable inputs to each of the nine studio Vision Mixers.

In addition, there are two complete groups of outputs to feed the English and French network and transmitter booths. It should be noted that all inputs do not go to all outputs of the Program Switcher. The first section feeding the cue and monitoring, recording room and booth switchers has access to almost all

feeds while the second section feeding the preselectable inputs to the studio Vision Mixers has access only to telecines, VTRs, input bays, slow-motion VTRs and test signals. In both the Equipment Room, at the Program Switcher racks, and Master Control, it is possible to monitor all inputs and all outputs to the Program Switcher as a check on its function, and it will also be possible from a maintenance point of view to operate any individual cross point at its rack location.

The combined audio and video Program Switcher occupies approximately 40 standard equipment racks (Figs. 2 and 3), the video section consisting of "paddle-wheel" assemblies each forming a 16 by 8 matrix, summing techniques then being used to form the large matrix to meet the specified performance tolerances. The audio section consists of a switcher controlled by the logic from the video section.

Of considerable interest is the method of control of the Program Switcher (Fig. 4). At each user's location there is a 10 pushbutton alphanumeric cluster together with a cancel and take button. In the case of a single cue monitor location the required source is keyed in and, after verification, operation of the take button will select the source. However, for the six assignable inputs to the Vision Mixer there is still only one pushbutton

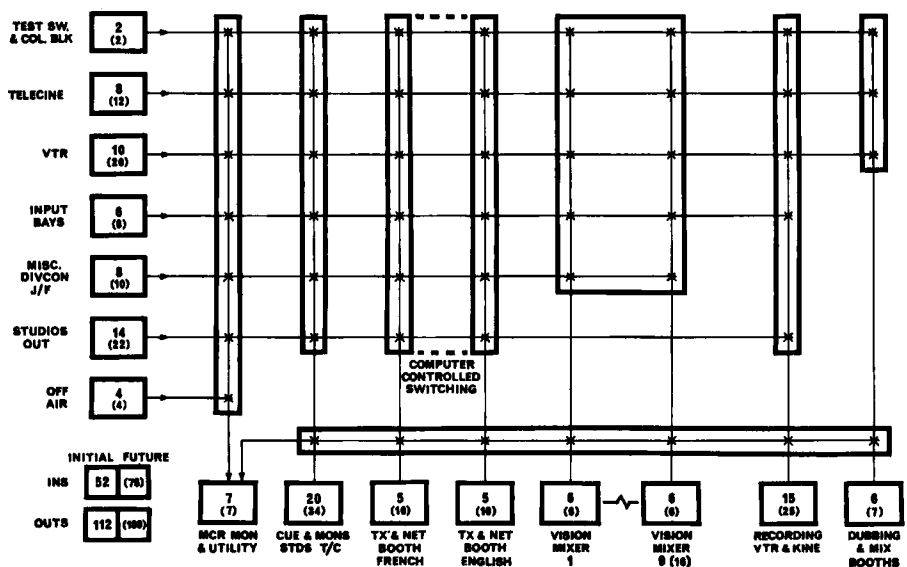

Fig. 1. Simplified block functional of the TV Routing Switcher.

Presented on 4 October 1971 at the Society's Technical Conference in Montreal by B. D. Baldry (who read the paper), G. A. Byrne and R. Savard, Engineering Headquarters, Canadian Broadcasting Corp., 7925 Cote Saint Luc Rd., Montreal 267, P.Q.

(This paper was received on 5 October 1972 and in final form on 12 January 1973.)



Fig. 2. Program Switcher: Shows approximately half of the Program Switcher, with video racks in the foreground, audio section at left.

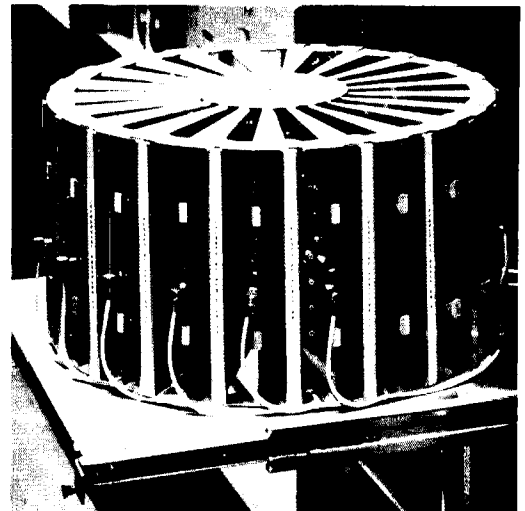

Fig. 3. Video Program Switcher: Radial Matrix Assembly.

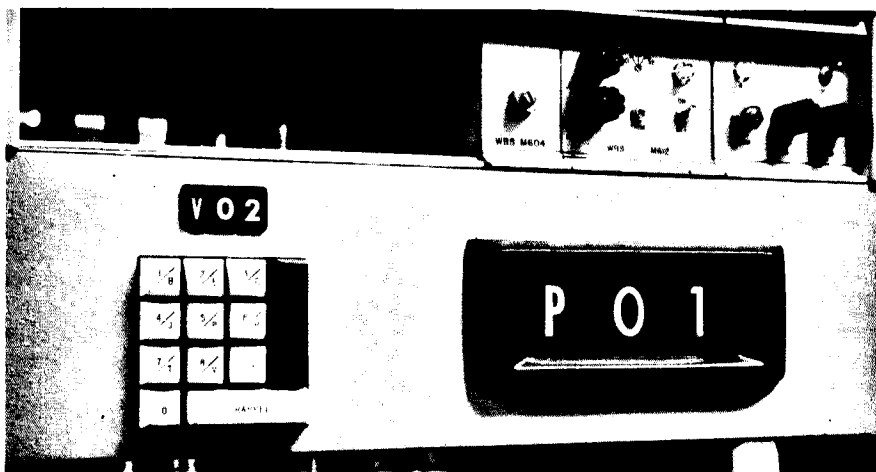

Fig. 4. Alphanumeric Cluster: Shows a readout indicating the existing selection PO1. The cluster has been used to key in VO2, now shown as the small verifier readout. Depressing the PRISE key would cause the large readout to change to VO2, confirming the accompanying video and audio selection.

cluster, and in this case the source identity is first keyed in, followed by the identity of the Vision Mixer input to which the source is to be assigned. A readout above the cluster confirms what has been selected. When the correct selection is verified the take button operates the audio-video portion of the Program Switcher and a readout on the appropriate monitor shows its source. Early thoughts on methods of implementing this type of control pointed to a total hard-wired logic approach with battery power failure protection. As the design developed it became apparent that a mini-computer could more readily perform the tasks of code translation and validity checking and provide a uniformity of interfaces between control panels, computer and switcher, coupled with a greater ease of system expansion and smaller size. Orderly power failure protection is also provided to protect the switching setup in the event of loss of primary power. Thus, each alphanumeric

cluster now becomes a terminal or peripheral of the computer.

The second portion of the TV routing system is the Control Assignment Switcher taking up another five racks of equipment. This routes control of any VTR, etc., to any remotely located control panel. Each studio Vision Mixer has an associated control panel for simultaneous control of two telecine chains and three VTRs, and these panels are provided with encoders which take the momentary pushbutton signals for machine control and convert them to digital commands transmitted over one pair of wires (Fig. 5). At each telecine chain and VTR there is an equivalent decoder which translates the digital command to operate the appropriate machine relay. Thus the machine control portion of the Control Assignment Switcher has to be capable of switching only one pair of wires which carry in digital form up to 32 separate commands. However, the analog controls of telecine functions are switched on a wire-for-wire basis because this was felt

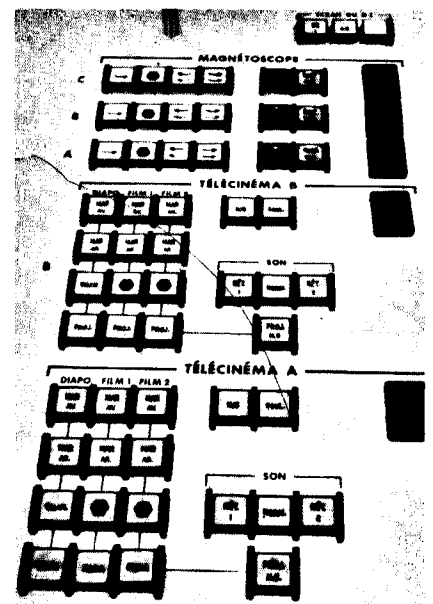

Fig. 5. Studio Remote Control Panel for VTRs and TCs: Control of two multiplexed TC chains and three VTRs is provided in each studio.

to be the most economical way at this time. All this is accomplished by use of sealed stepping switches which also serve to route the appropriate intercom and establish the correct pulse distribution where required. Provision has been made in the design of the Control Assignment Switcher for it to be controlled by a computer, such that a daily schedule could in the future be used to automatically set up the assignment of facilities throughout the plant, and an annunciator panel is provided at the Master Control console to indicate the status of all assigned telecines and VTR (Fig. 6).

The Pulse Assignment System is straightforward in that any studio may be assigned to one of a number of sync generator busses either for normal or genlock operation. Provision is made via

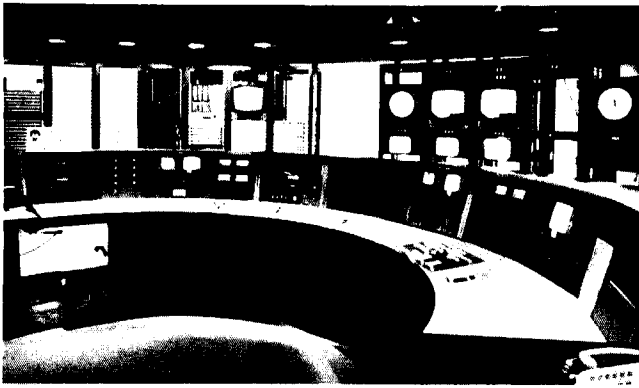

Fig. 6. General view of TV Master Control: At the center of the Console can be seen the annunciator panel for the Machine Assignment Switcher.

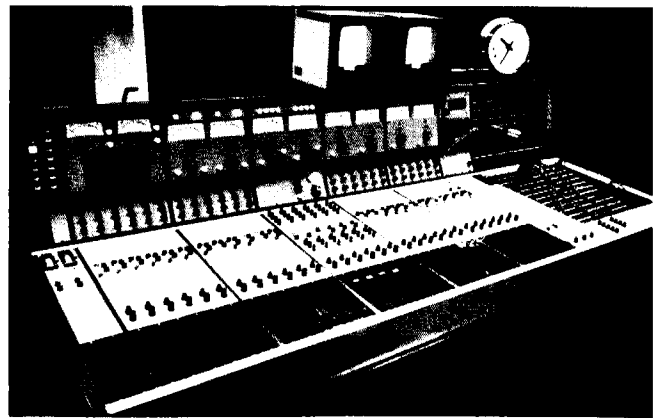

Fig. 7. Audio Production Console.

the Control Assignment Switcher for appropriate source equipment to pick up the same sync generator as that of the studio it is assigned to. The most novel feature is the manner of pulse distribution. Master Sync generators are provided which generate a color black signal only, which is distributed via a single level of switching and then at every source requiring pulses a slave generator is provided. This locks up to the selected color black signal and hence may be accurately timed and phased to a central reference point. With a switcher of this size, 10 busses by 72 outputs, the economy obtained by using single level switching far outweighed the cost of individual pulse generators and gave the additional benefit of simplifying timing and phasing problems.

Studio Vision Mixers

The nine studio vision mixers follow current Canadian Broadcasting Corp. practice functionally, having two sets of mix/effects busses with re-entry capabilities, a cut bus, an effects-key bus and a number of independently controlled preview busses for vision and lighting control, audio control, floor monitoring, etc. Of special note is the fact that the operating button signals from the Vision Mixers are digitally encoded and carried over a minimum number of wires and are unaffected by the very considerable distances involved, up to 800 ft (244 m) in the worst case. As mentioned previously, all the cameras assigned to a particular studio will be driven by a common slave generator and thus may be precisely timed to the Vision Mixer inputs. The remaining pre-selectable inputs which may have assigned a variety of VTRs, telecines, or remotes, will be equipped with auto-phasing units. It is the intention that initial timing of all the facilities will be within specified tolerances; however, it was felt that, over extended periods, variations of timing could take place both in the source equipment and in the routing equipment and so auto-phasers will act to cancel out

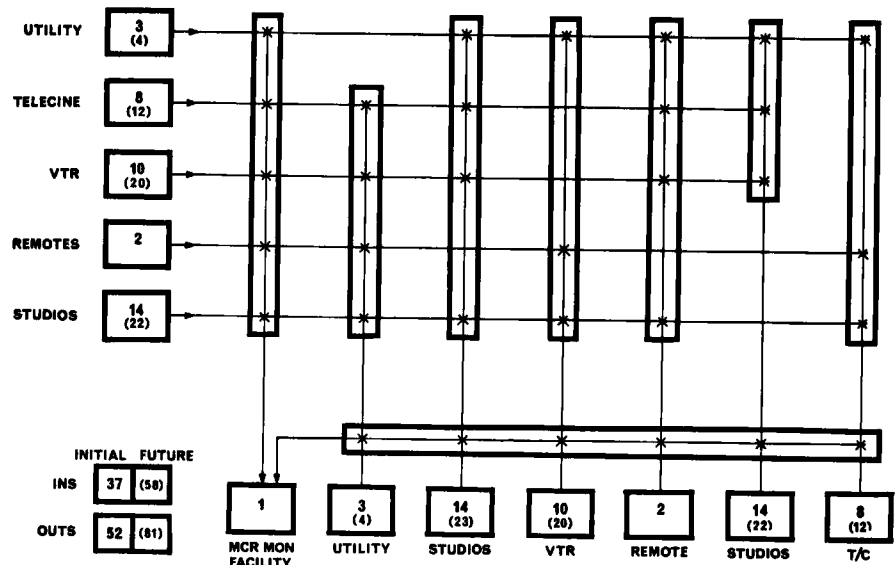

Fig. 8. Simplified block functional of the TV Intercom Switcher.

these variations and maintain the tolerances to the studio reference signal.

As mentioned previously, the two transmitter/network booth switchers form part of the main Program Switcher. These particular busses, however, will be controlled by two minicomputers and programmed from a punched card entry system. The daily log will be prepared on punched cards carrying duration time, real time, type of facility, mode of operation, type of transition, program title, etc. These are used to update the core memory, part of which is displayed on a picture monitor. The computer is programmed to perform all the necessary switching, machine control and transition selection to provide a smooth on-air program continuity. Each computer can handle two sets of program busses, one feeding the transmitter, the other the appropriate network, with override of all functions provided in case of equipment failure, or last-minute emergency programming.

TV Audio Consoles

In the interests of economy and flexi-

bility of usage all TV production studio audio consoles are designed identically to have 24 input channels when fully equipped, four auxiliary output channels, six sub-masters and two output channels (Fig. 7). Also provided are two echo send and receive channels.

Each input channel module is equipped with comprehensive features such as input sensitivity control; rumble filter; equalizer; multipoint take-off for echo, assignable to either of two echo send busses, together with solo and sound reinforcement take-offs. The sub-master channels have almost identical features to the input channels, additionally having pre- and post-fader assignment to the auxiliary channels. Jackfield facilities are provided for insertion of compressors, filters, special telephone effect switching, etc., into any selected channel.

Sound reinforcement facilities are being provided for all studios, the one for Studio 42 being the most elaborate. This studio has a permanent seating capacity of approximately 600 on two levels and the system must provide good quality to the audience without interference to the



Fig. 9. Live Camera CCU group; shown are three CCUs grouped with monitoring.

artists. A portable console to control the sound reinforcement is provided which may be operated from within the audience areas, or if required, moved to any other studio.

Sound-effects consoles are also provided for each studio. These have seven input channels and two outputs each and are designed to be transportable for use on remote pickups if required. Associated with these are turntables, tapes and cartridge tape units to facilitate the preparation of sound-effect material.

TV Intercom System

In a plant the size of Maison de Radio-Canada, the intercom requirements are very complex. The system can be considered in two sections. Firstly the normal studio, VTR or telecine matrixes, and secondly a central intercom routing switcher which connects these matrixes together as required. This approach enables intercom between points separated by over 800 ft (244 m) without the necessity of carrying control voltages over long distances (see Fig. 8).

The intercom routing switcher is controlled in one of two ways, either from the central master control position to establish intercom between outside feeds such as utilities or remotes and in-plant locations such as studios, VTR or telecine or, alternatively, it may be operated by the assignment switcher so that intercom for any VTR or telecine will automatically be connected to the appropriate studios for normal program preparation. In master control and at the equipment racks, complete monitoring is provided of all input and output circuits to allow the operator to either establish or test any intercom feed. An interrogate feature allows automatic cycling through

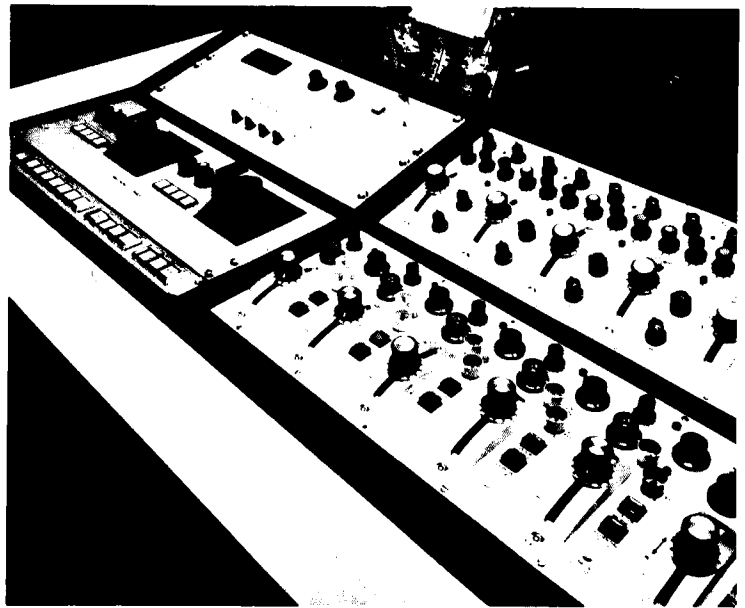

Fig. 10. Live and telecine camera remote controls: These are located in the Vision and Lighting Control Rooms; telecine controls are at left, cameras at right.

the routing switcher, displaying sequentially to the operator the assignment status of all manually assignable busses.

The studio intercom matrixes are fairly conventional in form, having the capability of linking key studio personnel to each other and their assigned facilities, telecine, VTR, etc. A privacy mode is provided for certain of the technical personnel so that setups and maintenance may be carried out without causing confusion on the general system. In addition, the studio matrixes have extensive paging facilities provided to enable artists and technicians to be called from make-up areas, dressing rooms, cafeterias, and corridors, etc.

Technical Clock System

The technical clock system is composed of a solid-state main master clock unit with automatic fail-safe change-over facilities in case of failure of the master unit, the main supply on the clock pulse amplifiers. The Master unit has a stability of one part in 10^9 per month and drives approximately 250 clocks in the TV and Radio technical and production areas. These clocks vary in size from 8 to 15 inches (20 to 38 cm) in diameter; some are illuminated, some not; and all are of a second jumping type with extra silent movements having a complete absence of backlash. A digital BCD output has also been provided to act as a time reference for the transmitter booth computers.

Live Camera Channels

The normal complement of cameras is as follows: Studios 43-47 have three cameras each, Studio 42 has four cameras and Studio 48 has two cameras. However, on occasion Studio 42 may

have its complement of cameras increased from four up to seven and Studio 45 from three up to six. The camera control units and encoders, in line with the general design concept, are located in a central area adjacent to the central equipment area (Fig. 9). At this point the CCUs are grouped by studios in two rows face-to-face for convenience of setup and monitoring, each camera group having monochrome picture and waveform monitoring and one color monitor shared between the cameras of each group. As mentioned earlier, each studio group of camera control units has directly associated with it a sync pulse generator, driven by the master color black signal. The generator will be locked to this signal and can then be phased so that the output of each studio arrives in correct time at the input to the Program Switcher. Those camera channels which are assignable between studios are handled a little differently to enable assignment, but the same end is achieved. In the Vision and Lighting control rooms directly associated with each studio there are located the Operating Control Panels (Fig. 10) for each camera which have on them an Iris and Master Black joystick, individual Black Levels for each color channel to compensate for drift, capping and setup controls. Also there is for each camera an Auxiliary Control Panel having a joystick type painting control. Waveform monitoring is provided for each camera including a match mode to aid in color matching the cameras in a studio to each other. Seated beside the studio video operator is the lighting operator and they maintain a close liaison to ensure that the resulting color pictures are of the best possible quality.

VTR and Telecine

The VTR operation is being set up on the basis of two-machine suites. Each of these suites is equipped with a production table which has facilities for laying voice onto the cue track of the machines for editing instructions. Adjacent two-machine suites have a sliding wall between them so that four VTRs may be under the control of one operator for a complex editing or dubbing session. A mix-booth is also provided in the VTR area which has full audio and video mix/effects facilities and the ability to add telecine inserts for packaging purposes. A total of nine VTRs will be installed, three new machines and the balance transferred from the existing facility. In all there are eight telecine chains, three transferred from existing

service and five new channels which are modified in details to equal the existing chain in colorimetry and monitoring facilities. Much has been done by the CBC in arriving at a uniform film reproducing system and the Maison de Radio-Canada chains will conform to this standard. Local controls are provided at the telecine chain which, after the projector, etc., are loaded, may be removed to the studio to which the chain is assigned, or to the appropriate CCU in the central CCU area. These controls are digital and analog and are handled as described in the Program Switcher section.

Conclusion

There are many other sub-systems in support of the major TV systems, such as

two film sound dubbing suites, five film screening theaters (one of 100 seats, one of 50 seats and three of 25 seats), six film evaluating rooms set up in accordance with Canadian Telecasting Practices CTP-1, and a number of small screening rooms in various departments. In addition, there are three kinerecorders, film processing and printing facilities as well as a 20-channel RF distribution system for house monitoring throughout the office complex, and two PABX for radio and TV technical telephones. All of these, together with the major system implementation, is representing a challenge to both CBC Engineering staff and the Suppliers now carrying out on-site installations.

Television Lighting Facilities of Maison de Radio-Canada

By TOM C. NUTT
and C. WILLIAM SHEARER

Lighting facilities in the seven TV Studios of Maison de Radio-Canada are described. These facilities are grouped with the video control equipment located in vision control rooms. Six of the studios are similar in design, layout and facilities provided. Power distribution to luminaires is via 162 outlets rated at 2-kW capacity and 81 at 5-kW. Four of the studios have their outlets and dimmers interconnected by slider (patch) power switching systems and the other two have dimmers rated at outlet capacity connected directly to the outlets. The seventh studio described has a production area of more than 5,000 ft.² (460 m²) and has a permanent seating arrangement for 668 (412 on the lower balcony and 256 on the upper balcony).

DURING THE past ten years the Canadian Broadcasting Corp., Engineering Division has designed and placed in operation 16 monochrome and 7 color TV studios.

The color conversion program commenced in 1965 when monochrome studios in Ottawa, Toronto and Montreal were converted. Simultaneously, the construction of the International Broadcast Centre for Expo '67 was supervised.

This design experience and the resulting operational feedback assisted in providing the requisite information required in the design of the lighting control systems and power distribution facilities for the television studios for the Maison de Radio-Canada project.

The original monochrome TV lighting control systems were similar in design and layout to theater lighting systems. However TV experience demanded that these systems evolve to an extent that masked their origin.

Presented on 4 October 1971 at the Society's Technical Conference in Montreal by Tom C. Nutt and C. William Shearer (who read the paper), Engineering Headquarters, Canadian Broadcasting Corp., 7925 Cote St. Luc Rd., Montreal 267, P.Q.
(This paper was first received on 5 October 1972 and in final form on 12 January 1973.)

In Fig. 1 is shown functional information for the most advanced monochrome system. Each of the two system masters, designated X and Y and the sub-preset masters, designated A and B in each preset, were followed by an emitter follower amplifier or impedance converter to reduce loading effects of following circuits and to maintain accurate and stable levels. The dimmers in the system were aligned to a linear light curve. This linear curve provided control scale readings between zero and ten which, when multiplied by ten, indicated the percentage of maximum light level; for example, a setting of 7 corresponded to 70% of maximum level. This curve and the action of the summing amplifiers feeding the dimmer control circuits provided dipless cross fading or a linear transfer from an outgoing lighting cue to an incoming cue.

In addition to the preset facilities, there were special-effects controllers directly connected to control busses or dimmers. These controllers are assigned to specific luminaires which require special monitoring such as individual key lights, etc.

There were two independent power sources for each console and circuit design is arranged so that the failure of

any one component cannot cause system failure.

Operating experience indicated that this system met all operational requirements with ease and provided the accurate repetition necessary for preset operation.

Discussion of lighting control facilities for color TV studios indicated that colored cyclorama lighting and associated lighting effects would demand more console control facilities. Each preset required additional switching to permit sub-division into more than the two groups of the existing monochrome system. Therefore, a five-position switch was provided for each preset controller permitting formation of one to five groups of controllers within a preset. Operation of three-position switches located near the sub-preset masters permitted each sub-master to control any combination of the five groups.

This control system design has proved to be adequate in two 6,000-ft² (560-m²) network color production studios; one in Montreal, the other in Toronto.

There are seven TV studios in the Maison de Radio-Canada, all with lighting and video control facilities in a vision control room. Thus, the video and lighting console operators are in direct communication and work with the same monitors to produce the final picture.

Six of these studios, numbers 43 to 48, are provided with walkway grids. Figure 2 is a view from above the grid during final assembly. Note the clear head room of a nominal 7 ft (2.3 m) above the grid. These walkway grids are installed 15 ft (4.6 m) above the studio floor. Figure 3 shows the appearance of