

tension on an aluminum frame. Each screen is equipped with an adjustable support, so that the screen may be used either free standing or hung from a wall. The screen support is adjustable, so that the screen can be locked to the wall surface at a specific angle to eliminate keystone. The new screens reflect projected light in an oval-shaped cone with a horizontal spread of about 110° and a vertical spread of about 30°. The screens are available in three sizes—48 by 48 in at a price of \$69.50; 36 by 48 in at \$49.50 and 24 by 32 in at \$39.50.

The Lectron solid-state control designed

for use with slide projectors in the 500- to 1000-W range, has been announced by Lectron Corp., 21839 S. Avalon Blvd., Carson, CA 90745. The control, providing surge-free starting and regulation, is reported to increase the life expectancy of the lamp to about twice that without use of the control. The control contains an air-gap disconnect as well as a fuse for protection against overload. Features include smooth, surge-free turn-on from zero to steady state; overvoltage regulation; pilot light indicator; and life expectancy in excess of 100 million cycles. The control contains 100 in³ and weighs 3 lb. The price is \$77.50.

CLASSIFIED ADVERTISING

First 3 lines \$10.00
Each Additional line \$2.00
per inch \$26.00

Equipment available \$500—Oscar Fisher Processall, model #G-12, 316 stainless steel, handles film or paper up to 12 inches wide, at speed 12 F.P.M. for each roll, good for black and white but not reversal. Daylight loading. L. B. Russell Chemicals, 14-33 31st Ave., Long Island City, NY 11106 Telephone (212) 721-8900.



employment service

These notices are published for the service of the membership and the field. They are inserted three months, at no charge to the member. The Society's address cannot be used for replies.

Positions Available

Optical and Special Effects Photographer. This is an unusual opportunity for a professional to supervise an Optical Department in one of the country's best and most progressive full service labs. If you are looking for a challenging career where you can use your experience and creativity, we have the equipment to provide it. Please write Scott King at WRS Motion Picture Labs, 210 Semple St., Pittsburgh, PA 15213 or call (412) 683-6300.

Designer/Engineer. To work with rapidly expanding Virginia instrumentation camera manufacturer in medical, aerospace, microfilm and surveillance fields. A knowledge of optics and electronics is required. Large film format, pulse and cine background would be desirable. A general knowledge of instrumentation equipment and data reduction techniques helpful. Send resume to: Arthur Dorman, Instrumentation Camera Corp., 97-45 Queens Blvd., Rego Park, NY 11374, (212)275-3400.

Video Engineers and Technicians. Fully experienced in maintaining color cameras, 2-in, 1-in. & ½-in VTRs using latest Tektronix test equipment. Excellent salaries for right men. Send resumes to: Phil Dewald, F&B/Ceco of Calif., Inc., 7051 Santa Monica Blvd., Hollywood, CA 90038, or Walter Druker, F&B/Ceco Inc., 315 W. 43rd St., New York, NY 10036.

Photo Equipment Technician. Arriflex Co. of America, importer of Arriflex professional motion-picture equipment, is seeking experienced technicians to service same. Offices in New York and California. Positions available at both locations. Excellent starting salary, fringe benefits, growth potential. In New York call (212) 932-4040. In Calif. (Burbank) call (213) 843-1883.

Positions Wanted

Grad Student. Currently attending USC-Cinema, seeks employment in TV-related industry. BA in theatre/cinema; MS in cinema. Experience in audio/visual communications, film, TV. Will relocate, will travel. Wm. B. Mc Govern, 2324 Scarff St. #2, Los Angeles, CA 90007. (213) 748-4466.

Director-Producer. Award-winning filmmaker presently seeks new assignments on free-lance basis. Also function as soundman—own Nagra IV, etc. Will travel. Chas. Salmore, 2341 Glendon Ave., Los Angeles, CA 90064, (213) 270-3526.

Production Generalist. Four years ETV production and TV production instructor; nine years nontheatrical motion-picture production; four years radio, TV, and motion-picture public relations for national service organization; four years A/V production, supervision, and consultation for state agency. Phased out in administration change; seeks new challenge building on richly varied past experience. Masters degree. Detailed information on request. Norman Ross, 3670 Moundford Ave., Decatur, IL 62526, (217) 877-0262.

Film Production or Promotion. Assistant Professor of Speech and Drama, experience in theater production facilities and phases of both theater and film studies and teaching, desires opportunity in a production organization, including writing and public relations. Robert L. Richey, 847 N. Main St., Lindsborg, KS 67456, (913)227-2127.

Journals Available/Wanted

These notices are published as a service to expedite disposal and acquisition of out-of-print Journals. Please write direct to the persons and addresses listed.

Exchange: USC Cinema Div. has an exchange-of-extra-journals program with libraries in colleges and industry. Anyone interested in exchanging duplicates for missing copies or donating Journals for this purpose should contact Herbert E. Farmer, Division of Cinema, University of Southern California, University Park, Los Angeles, CA 90007.

Available. Dec. 1945–Mar. 1952, plus 1936–1945, 1946–1950 indexes; 1946 and 1950 Membership Directories; Theatre Television (1949); High-Speed Photography, Mar. 1949 (2 copies) and Nov. 1949. John P. Lowe, Avery Hts. Dr., Holden, MA 01520.

angénieux

offers the widest selection of zoom lenses and interchangeable viewfinders including the most advanced automatic iris system for the professional motion picture industry

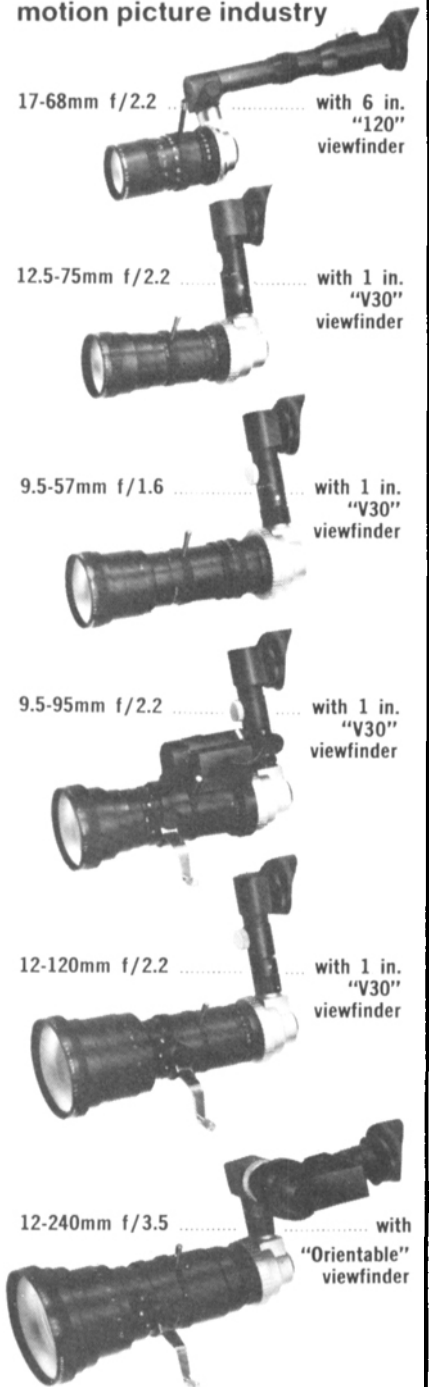

Available from leading camera manufacturers and their dealers throughout the world.

For further information and technical specifications call or write ...

angénieux corporation of america

440 Merrick Rd., Oceanside, N.Y. 11572 • (516) 678-3520
13381 Beach Ave. Venice, Calif. 90291 • (213) 821-5080