

## NEW MOTION PICTURE APPARATUS

*During the Conventions of the Society, symposiums on new motion picture apparatus and materials are held, in which various manufacturers of equipment describe and demonstrate their new products and developments. Some of this equipment is described in the following pages; the remainder will be published in subsequent issues of the Journal.*

### A MOBILE SOUND RECORDING CHANNEL\*

L. T. GOLDSMITH AND B. F. RYAN\*\*

The portable unit described herein is one of seven such units recently built for Warner Bros. Pictures, Inc., by RCA Manufacturing Company, and is aptly termed "a mobile sound recording channel," for, in contrast to the average location truck, nothing of the performance of a fixed studio channel has been sacrificed in achieving portability. The equipment is of the highest grade and is interchangeable with similar units in use in the fixed channels.

Fig. 1 shows the truck ready for recording, with the mixer case set up and the microphone connected. The body and cab are built on a standard four-speed, two-ton Ford chassis. The color scheme is red, blue, and white, with chromium strips to give the illusion of length. Actually, the wheel base is only 157 inches, and the overhang at the rear is small, so as to allow good maneuverability in woods and on mountain roads. All batteries are set low, resulting in a low center of gravity and good stability on curves and grades. The body is insulated with three inches of kapok, and the roof is painted with aluminum paint to reflect the heat of the sun.

Instead of a microphone boom, a two-sectioned jointed duralumin pole is provided to hold the microphone. This pole can be held by hand or mounted upon a lamp-stand, and has proved far superior to other types of boom on location. The microphone is insulated from the pole by rubber. Wind and rain screens are provided for the microphone so that recordings can be made under all but the severest conditions. Running shots, disk and film playbacks, and process projection work can all be handled as easily with this unit as with any fixed studio installation, so that it has actually proved itself a mobile recording channel.

Fig. 2 is a rear view, with the doors open. On the right are the large cable reels, operated by detachable handles from the inside of the truck. Sufficient cable is carried on the reels for recording at a distance of 1000 feet from the action. On the left is the plug panel for connections to the portable mixer and camera motors. All plugs are plainly marked and are poled so that it is impossible to

---

\* Presented at the Fall, 1937, Meeting at New York, N. Y.; received October 4, 1937.

\*\* Warner Bros. Pictures, Inc., Burbank, Calif.

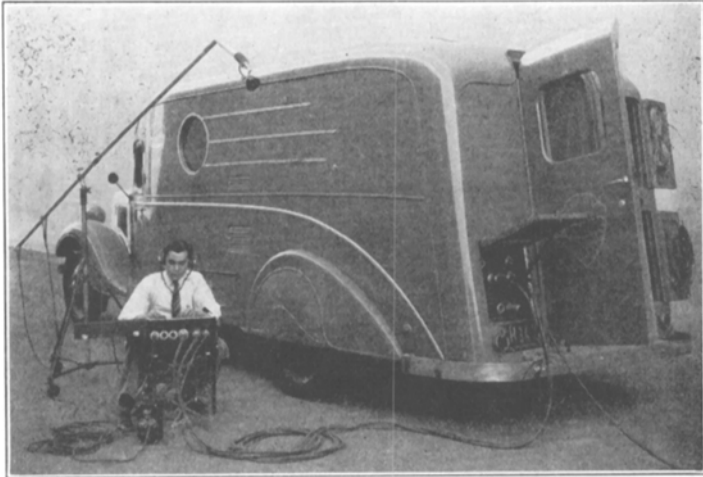

FIG. 1. Location truck set up for recording.

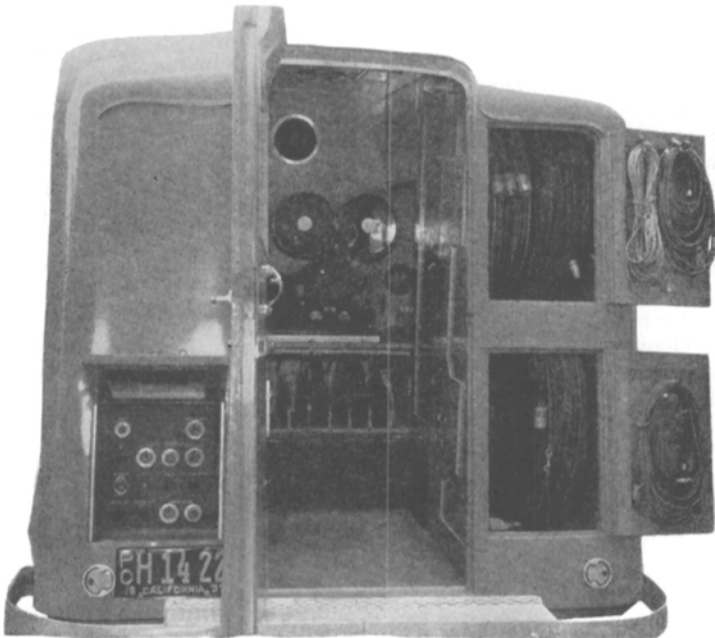

FIG. 2. Rear view of location truck.

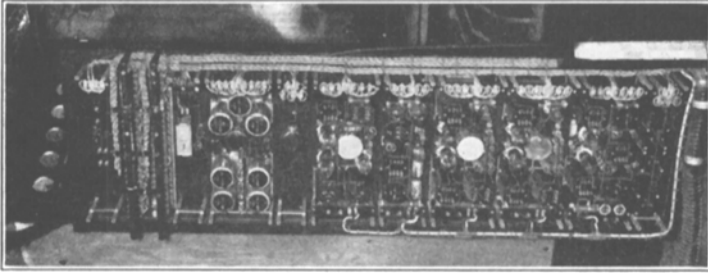

FIG. 4. Rear of amplifier rack.



FIG. 3. Interior of location truck.

make mistakes in connections. Despite the low height of the truck, the head room is six feet one inch. The top of the door follows the curve of the body, eliminating stooping when entering.

The body is divided into front and rear sections. Fig. 3 shows the interior of the rear compartment. On the left are the amplifier rack and the power control panel. In the center is the RCA ultraviolet light recording machine. Either



FIG. 5. Front compartment.

push-pull or standard bilateral shutter track may be made. The recording machine connections are brought to plugs so that machines for different types of recording can readily be substituted. Beneath the recorder is space for ten double film magazines. The compartment can be converted easily into a dark-room for loading and unloading magazines on location if desired.

The amplifier rack contains all the amplifiers, filters, and noise-reduction equipment necessary for recording. The rack is of duralumin, and the amplifier

units are mounted on standard 19-inch aluminum panels finished in black alumi-lite. All input and output connections are brought out to jacks, to provide ease in testing and locating trouble. Each unit is individually fused in both high- and low-voltage circuits. A special airplane-type 250-volt dynamotor driven from the 110-volt motor battery supplies the amplifiers through appropriate filters, eliminating all "B" batteries. The noise-level for normal recording gain of the complete amplifier system, with all rotating equipment in operation, is 65 db. below 100 per cent modulation. This is considerably lower than the noise-level of many permanent installations.

The power control panel is alongside the recorder and contains all controls in addition to those on the machine needed by the recordist during operation. At the top are the charge-discharge meters and the 110-volt d-c. voltmeter. Below these are the charge-discharge switches and the two end-cell switches for an additional 6 or 12 volts when the service is unusually severe. In addition to the 110-

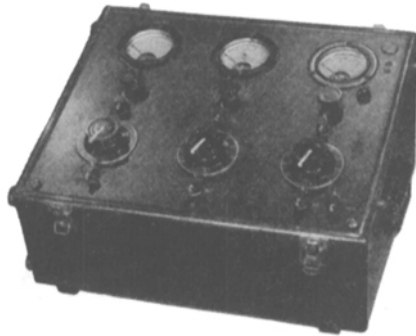

FIG. 6. Mixer case.

volt motor battery, there is an 8-volt amplifier battery and a 14-volt recording lamp battery. The truck can be used for two full days and nights of recording without recharging batteries, and the battery capacities are so chosen that all batteries are discharged in approximately the same time. Below the switches are the a-c. and d-c. voltmeters for interlock voltage and plate voltage and a large size speed indicator. Along the bottom of the panel are the starting switches and the lights and fan switches. Lights are of the tubular type, recessed in the ceiling on each side of the recorder, and an exhaust fan in the ceiling provides ventilation in hot weather. The lights and fan can be switched from the 110-volt battery to a 110-volt a-c. circuit if the latter is available from an outside source.

Fig. 4 shows the amplifier rack swung out for servicing. The equipment covers have been removed so as to show the workmanlike job of wiring. The rack wiring is of the highest grade airplane type, No. 16 stranded wire, and is led to the rack in a length of flexible conduit. High- and low-level circuits are in separate forms on the rack and cross-talk is reduced to a negligible quantity. Only three types of standard RCA tubes are used throughout the entire recording system.

The heavy wiring to the power control panel prevents swinging this panel out-

ward, as in the case of the amplifier rack. The service door is located at the rear of the panel on the left side of the body. All parts are stencilled and all wiring is in conduit and is color-coded. At the top is a work light and at the base are soldering iron outlets.

The front compartment of the truck, as shown in Fig. 5, contains all the rotating equipment and the small accessories used on the set. By locating such equipment forward, the stage helper need not disturb the recordist as he collects his mixer case, telephone set, microphones, *etc.*, and the recordist is left free to prepare his equipment for recording. The battery chargers are in the background. Auxiliary outlets are provided for the mixer case so that mixing can be done in the front compartment if desired. The windows can be lowered, and a ventilating



FIG. 7. Pre-amplifier and microphone.

fan and lights are provided. The same type of selsyn motor system is provided as is used in the studio. This has been found to be very desirable and allows playback and process projection equipment to be operated in synchronism with the cameras. The machine compartments are sound-proofed with lead and felt so that the truck is quiet enough to operate right on the set if desired.

Fig. 6 shows the mixer case. It is built of duralumin with a black alumilite finish, and is provided with a collapsible stand of the same material. Three mixing positions are available and facilities are provided to read and adjust heater and plate currents to the microphone pre-amplifiers. A high-speed extension volume indicator is supplemented by the latest type of high-quality monitoring head-phones. A telephone subset connects the mixer with the recordist and an extension connects with the stage helper at the microphone.

Fig. 7 shows the portable pre-amplifier and the type 630 microphone. The pre-amplifier has two stages of amplification and a gain of 48 db. It can be plugged into the line anywhere between the microphone and the mixer case. On

long microphone runs it is used at the microphone, to raise the speech level well above line noises caused by lighting cables or electrical interference of any kind on the set. A radio-frequency filter is incorporated in the circuit to prevent radio pick-up when recording near broadcast antennas and aboard ships. Fig. 8 shows the pre-amplifier with the cover removed. The tube shelf may be opened for ease of servicing.

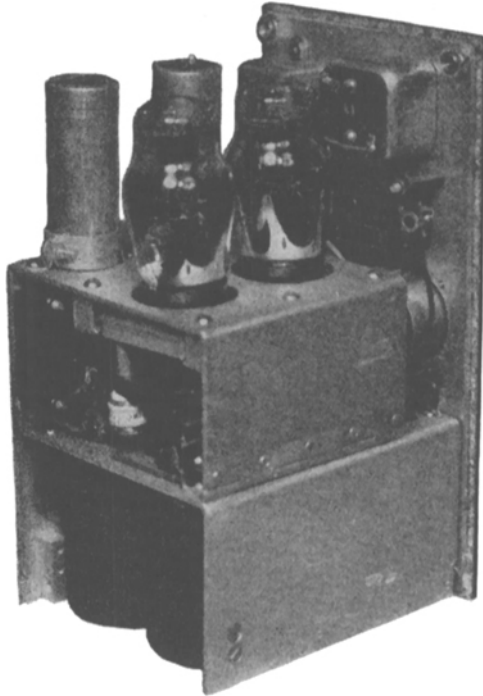

FIG. 8. Pre-amplifier, without case.

Fig. 9 is a block diagram of the recording circuit. For recording music, the frequency response is flat within  $\pm 1$  db. from 40 to 9000 cps. For recording dialog the low end of the characteristic is reduced 6 db. at 100 cps. by a dialog equalizer in the pre-amplifier, the response is sharply cut off below 100 cps. by an 80-cycle high-pass filter, and the high end is always cut off at 9000 cps. by the 9000-cycle low-pass filter. Upward equalization is available by means of a high-frequency equalizer ahead of the recording amplifier. In general, a gradual 3-db. rise is used from 1000 to 7000 cps.

The mixer amplifier and recording amplifier are two-stage amplifiers, each having a gain of 50 db. Two units are used for ease of inserting filters and to render the equipment interchangeable with fixed-channel equipment in which the mixer amplifier is in a tea-wagon console on the stage and the recording amplifier in a central recording building. The overall harmonic distortion of the recording sys-

tem is less than one per cent at an output of +22 db. above a zero power level of 6 milliwatts. This output level is 6 db. above 100 per cent modulation of the recording galvanometer.

The motor circuit consists of a 220-volt, 3-phase, 60-cycle, 1.75-kva. converter, driven by a 110-volt storage battery supplying interlock voltage to a 3-phase distributor driven by a 1/8-hp. 110-volt d-c. motor. As many as eight cameras can be interlocked with the recording machine and distributor. Normally the motor

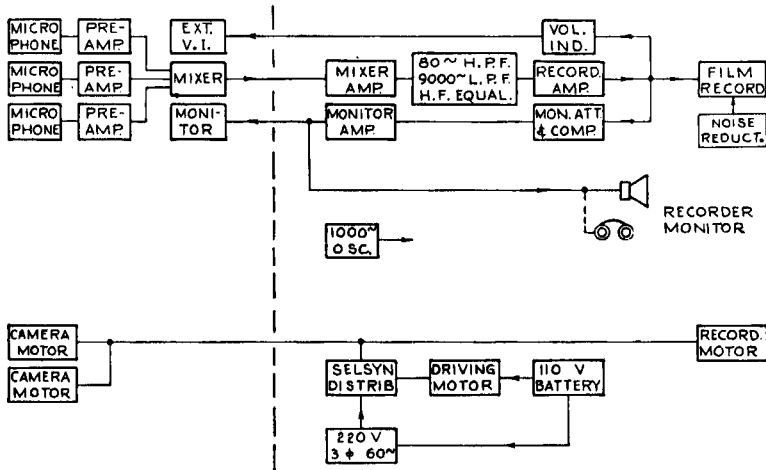

FIG. 9. Diagram of recording circuit.

speed is held at 1200 rpm. by a flywheel and butterfly type of control on the d-c. motor. The control can be cut out, however, and rheostats used to vary the speed from 900 to 1400 rpm. for undercranking or overcranking the cameras. A synchronizing circuit is provided that fogs the film in the camera and opens the bias circuit of the recorder when the system is up to speed. A limited power supply at 110-volts a-c. for playback and public-address amplifiers is available from the converter through a 3-phase 220/110-volt transformer.