

Testing of the Grand Alliance HDTV Transmission Subsystem

By Jules Cohen and Victor Tawil

An 8-VSB transmission subsystem was selected by the Grand Alliance and approved by the FCC Advisory Committee on Advanced Television Service as a component of the HDTV system intended to substitute for the NTSC system now used for television broadcasting in North America and other parts of the world. Selection was made on the basis of laboratory testing. To determine the suitability of the system for terrestrial broadcasting and cable distribution under real-world conditions of propagation, tests were conducted in the vicinity of Charlotte, N.C., employing both VHF channel 6 and UHF channel 53. The system was found to meet expectations, somewhat exceeding the performance of NTSC, even though the average effective radiated power (ERP) for the HDTV system was 12 dB below the peak visual ERP of the NTSC system. The results of the tests are discussed in this paper.

The Grand Alliance, a consortium formed by AT&T, David Sarnoff Research Center, General Instrument Corp., Massachusetts Institute of Technology, North American Philips Corp., Thomson Consumer Electronics, and Zenith Electronics Corp., proposed the use of the eight-level, vestigial side band (8-VSB) transmission subsystem after comparative testing of 8-VSB and 16-state quadrature amplitude modulation (16-QAM) at the Advanced Television Test Center (ATTC) and CableLabs. A 16-VSB system for use in cable television systems was proposed also. The Advisory Committee on Advanced Television Service (ACATS) concurred in the recommendation.

In the spring of 1994, a prototype 8-VSB transmission subsystem was delivered to the Charlotte, N.C., advanced television test site for testing in the terrestrial broadcasting environment pursuant to procedures developed by the Systems Subcommittee Working Party Two (SS/WP-2) Field Testing Task Force. Additionally, a

16-VSB prototype was made available for cable television tests. Since only the transmission subsystem was available for testing, modulation of the advanced television (ATV) signal was with pseudorandom noise only. The NTSC signal, employed for comparison purposes, was modulated with picture and sound.

The primary objective of the field testing program is to evaluate the performance of the transmission subsystem under real-world conditions of multipath and other propagation phenomena. An important part of that evaluation is a comparison of the advanced television (ATV) system with the NTSC system, which has provided domestic television to North American viewers for 50 years. Stated otherwise, can the 8-VSB transmission system provide satisfactory picture and sound where NTSC reception is satisfactory or, even better, might the newer system provide reception in locations where NTSC service is not satisfactory? Contrary to the gradual degradation of NTSC performance as signal strength decreases or interference increases, digital transmission reception above the threshold of visibility of interference (from either noise or other stations) can be expected to be an almost exact replication of what was trans-

mitted; then, when the threshold is reached, picture and (likely) sound as well, are lost.

Both VHF and UHF performance of the system were deemed necessary. The Federal Communications Commission (FCC) granted experimental authority to operate on VHF channel 6 and UHF channel 53, based on a study indicating that use of these channels presented little likelihood of causing interference to, or receiving substantial interference from, any existing television broadcast operation. As will be noted here, the use of channel 6 presented an unexpected opportunity to observe problems of interference to cable reception. This paper describes the facilities employed, the test procedures used, the analysis method, and the experimental results.

Field Test Plan

The SS/WP-2 established a Field Testing Task Force to deal with field testing issues. A procedure for field testing was developed by that task force and submitted to the SS/WP-2 parent body for approval. Implementation of the plan is described in the following paragraphs.

An initial task was the selection of a suitable transmitting site. The objective in site selection was to permit observation of system performance under varying conditions of propagation. Terrain in the site vicinity would need to range from relatively smooth earth to that with sufficient irregularity to assure that some receiving locations, although within nominal line-of-sight for smooth earth, would be obstructed. In addition, some receiving locations would be in a community of substantial size, other locations would be in smaller communities, and still others in a rural environment. Fortunately, a site meeting those requirements was available near Charlotte, N.C.

Presented at the SMPTE 136th Annual Technical Conference in Los Angeles (paper no. 136-27) on October 14, 1994. Jules Cohen is with Jules Cohen & Associates, P.C., Washington, DC 20036; Victor Tawil is with the Association for Maximum Service Television, Inc., Washington, DC 20036. Copyright © 1995 by the Society of Motion Picture and Television Engineers, Inc.

At the field testing site in Charlotte, a 1,337-ft tower and transmitter building were made available by Lodestar Charlotte, Inc., and the former owner of the tower, Journal Broadcasting of Charlotte, licensee of WCNC-TV. The availability of the tower and building is of prime importance, but the area also provides a number of other advantages. Weather in the Charlotte vicinity provides decidedly different conditions with seasonal changes but is sufficiently mild so that outdoor measurements can be conducted throughout the entire year. A variety of terrain conditions in the area permits consideration of terrestrial broadcasting performance over paths ranging from relatively smooth to sufficiently irregular to produce many obstructed receiving points. The city is of such size that urban reception conditions can be explored, and smaller communities in the vicinity permit the exploration of what may be termed a suburban environment. In addition, a number of technically diverse cable systems serve the area and were made available to CableLabs for its study of transmission subsystem performance using working cable systems.

Transmitters, transmission lines, transmitting antennas, a field truck, translator, and a substantial amount of test equipment were loaned to the project. The transmitter building houses two transmitters: a Comark UHF transmitter with inductive output tube (IOT) output stage operating on channel 53, and an LDL Communications, Inc., solid-state VHF transmitter operating on channel 6, together with associated test equipment. Zenith provided an 8-VSB modulator for use when either transmitter is delivering an ATV signal. An omnidirectional, top-mounted TFU-24G UHF antenna was provided by Dielectric. Just below the UHF antenna is a single-bay, omnidirectional VHF panel antenna from Harris Corp. In addition, Andrew Corp. provided a directional UHF antenna, which is side-mounted on the tower.

For NTSC operation, peak visual ERP used was 10 kW at channel 6 and 500 kW at channel 53. ATV average ERP was 0.63 kW for channel 6 and 31.6 kW for channel 53,

each 12 dB below NTSC peak visual ERP. The 12-dB value was determined using the planning factors recommended by Planning Subcommittee Working Party 3 (PS/WP-3) to achieve ATV and NTSC equivalent service.

The field truck, loaned by Harris Corp., is complete with AC generator and extendible mast. Installed equipment includes a consumer-type Delhi Model VU-932, all-band receiving antenna, field strength meters, NTSC receiver with switchable ghost canceller, vector signal analyzer, spectrum analyzer, Tektronix demodulator, personal computer (PC) for both control and collection of data, waveform monitor, D-3 videotape recorder (VTR), VM700 video measuring set, bit error rate (BER) measuring equipment, noise generator, amplifiers, attenuators, splitters, and cabling. The Zenith 8-VSB demodulator with associated computer and test equipment provided the capability of reading signal-to-noise ratio (SNR) at both the input and output of the equalizer, equalizer tap energy, and segment error rate. For communications with the transmitter and elsewhere when necessary, the field truck is equipped with both a broadcast auxiliary transceiver and cellular telephone.

Block diagrams showing the interconnection of the transmitter building equipment and the field truck equipment are shown in Figs. 1 and 2, respectively.

Basic testing included measurements and observations at 199 locations. Of the 199 locations, 128 were along eight radials extending to 55 miles (88.5 km) from the transmitter. The radial directions were selected to provide a range of terrain conditions. The remaining locations were in two large grids with one-mile (1.6-km) spacing and three small grids, or clusters, with one-half mile (0.8-km) spacing. One grid and one cluster are located in Charlotte; the second grid and second cluster are located in the smaller community of Rock Hill, S.C. The third cluster is located approximately 2.5 miles (4.0 km) from the transmitter, selected to provide information on performance of the antennas at relatively large depression angles.

Transmitter and field truck calibrations were carried out at the start of each day's work, and critical parameters were again checked at the end of the day. Transmitter and field truck calibration include: NTSC and ATV power, frequency, visual-to-aural carrier ratio (NTSC), linearity, differential gain, intercarrier phase modulation (ICPM), ATV peak-to-average ratio, ATV pilot carrier frequency, transmitter noise floor, adjacent channel roll-off, carrier-to-noise ratio (CNR), ATV equalizer tap settings, field truck system net gain, and field truck noise floor.

At each test location, field strength was recorded on both channels 6 and 53 while moving the field truck over a 100-ft path with antenna erected at 30 ft above ground. As noted later, channel 6 measurements had to be curtailed at a minority of the sites to avoid interference to reception on cable channel 6. After completing the 100-ft run, the field truck was returned to the center of the path for measurements and observations at a fixed site. To avoid receiver overload, attenuators were set in strong signal areas to provide suitable input level. (The function of the attenuator setting is comparable to the automatic gain control [AGC] of a television receiver.) NTSC peak sync level, noise floor, CNR level over the 6-MHz band, and video SNR were measured. The NTSC picture impairment rating, using the CCIR five-point grading scale, was determined both with and without ghost cancellation and comments were noted relative to the impairment characteristics. A spectrum analyzer "snapshot" and co-channel interfering signal level (if any) were recorded, as well as channel characterization data using equipment provided by the Institute of Telecommunication Science (ITS) of the Dept. of Commerce National Telecommunications and Information Administration (NTIA).

ATV data collected includes equalizer SNR at the input and output of the equalizer, equalizer tap energy, input signal level, pilot level, BER, segment error rate, noise floor, and margin to the BER (3×10^{-6}) previously determined in the laboratory to correspond to the threshold of visibility. Margin

UHF RF Transmission System

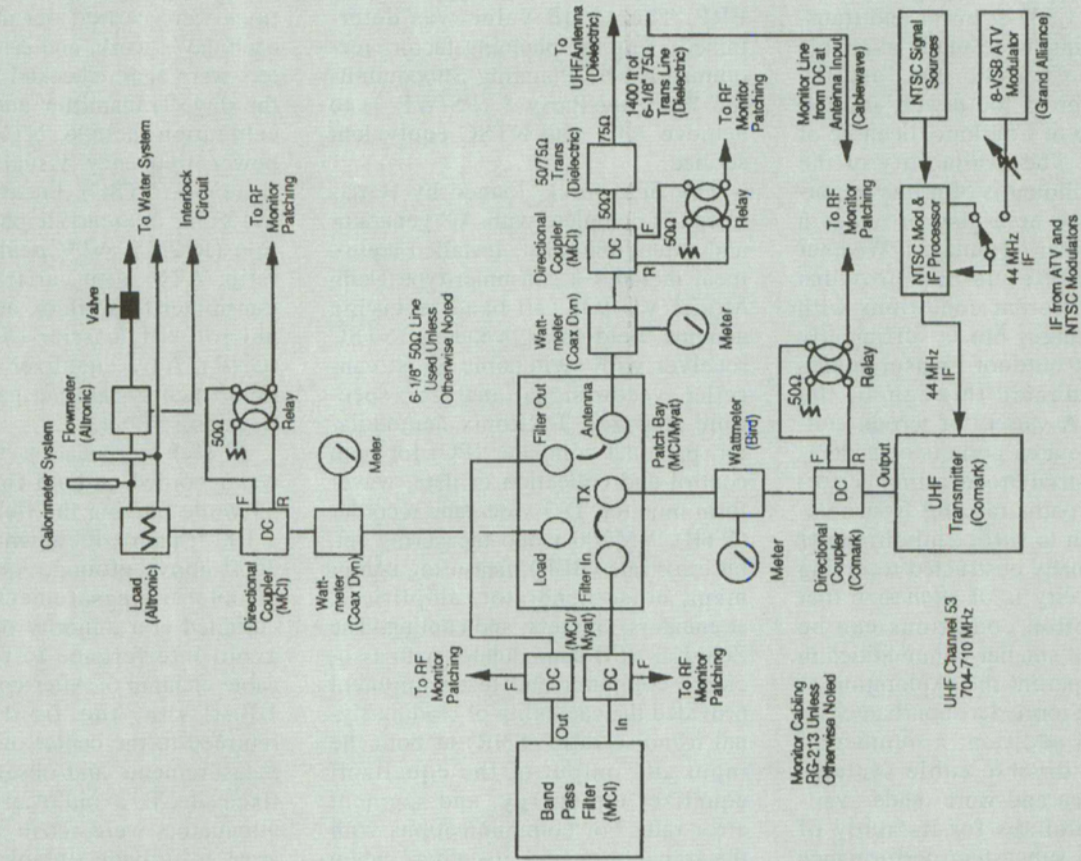

VHF RF Transmission System

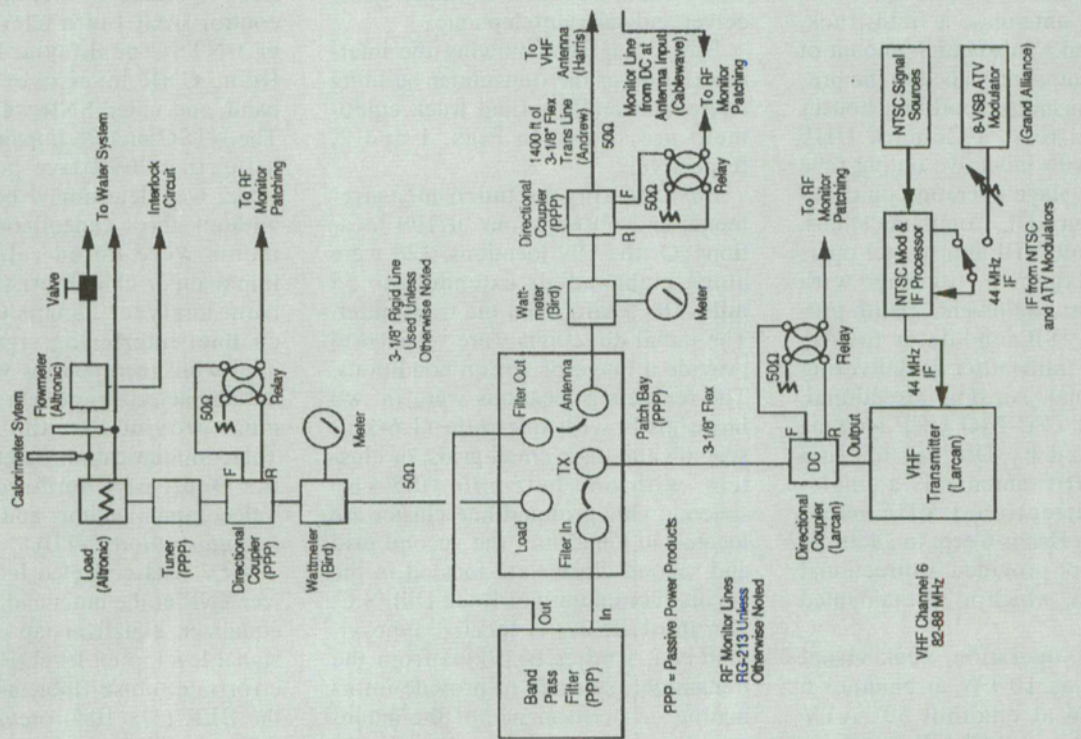

Figure 1. Signal sources and RF power monitoring.

TECHNICAL PAPER

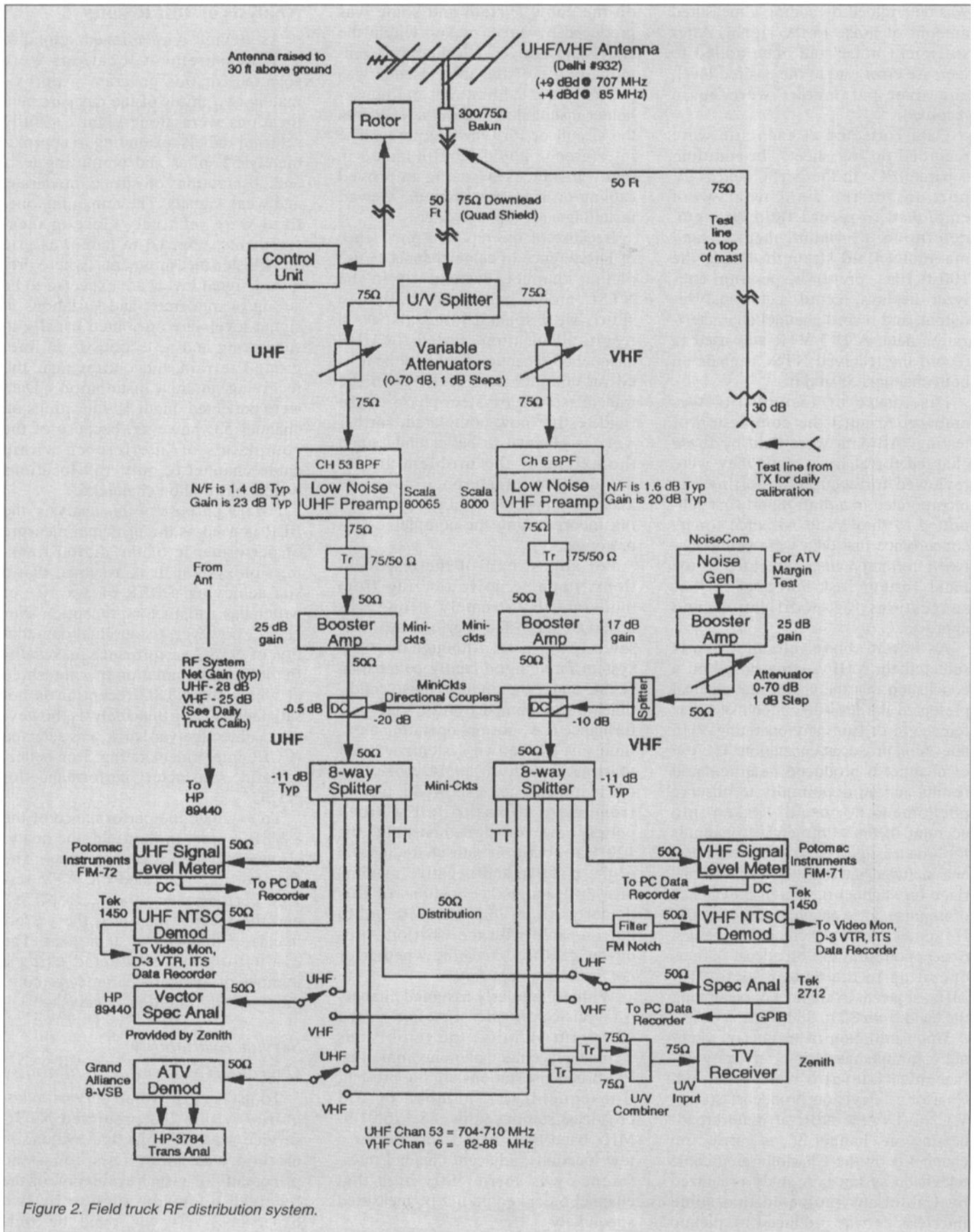

Figure 2. Field truck RF distribution system.

was determined by adding a measured amount of noise to the signal. After sufficient noise had been added to increase error rate to the desired level, equalizer parameters were again recorded.

Data collected at each site were recorded on log sheets. In addition, separate PCs in the NTSC and ATV portions of the field truck were employed to record field strength, determine minimum, median, and maximum field strength during the 100-ft runs, preserve spectrum analyzer displays, record vector analyzer output, and record channel characterization data. A D-3 VTR was used to record the received NTSC signals on both channels 53 and 6.

Disclosure of test results was embargoed until the completion of testing. All data were held by those charged for analysis until they were reviewed for accurate reporting and incorporated in a draft report first submitted to the Grand Alliance for its concurrence that data were being analyzed correctly, then submitted to the Field Testing Task Force for review, suggestions for modification, and approval.

As noted above, channel 6 was selected for VHF testing based on a conclusion that the use of that channel presented the least likelihood of interference to or from any operating VHF television broadcasting station. The use of channel 6 produced unanticipated results and an opportunity to observe phenomena not usually taken into account in the allotment of channels for broadcast purposes. Those phenomena included interference to cable carriage on channel 6; a high prevalence of impulse noise originating from a 60-Hz source; and interference to channel 6 reception from FM broadcast stations operating in the band 88.1 to 91.9 MHz, adjacent to channel 6, occupying the band from 82 to 88 MHz.

Upon initiation of testing on channel 6, complaints of interference within cable channel 6 were received. Charlotte television broadcast station WCNC-TV, the NBC affiliate broadcasting on channel 36, is carried on channel 6 by the Charlotte area cable television systems. A study organized by CableLabs indicated that some interference was produced by pickup

on the cable system and some was produced by direct pickup within the television receiver, but the most common source of the interference was probably the cabling that the householder installed to connect a VCR into the circuit or for other purposes. The interference could be eliminated in many instances by using improved cabling or, if permitted by the viewer, installing a set-top converter.

Because of the reported prevalence of interference to cable channel 6, use of that channel, particularly in the NTSC mode, had to be limited to short, well-spaced intervals. As a result, all locations tested for UHF channel 53 reception could not be tested on channel 6 as well. With the transmission subsystem phase of the field testing now completed, further work is planned to better understand the extent of the problem and to decide how interference might be avoided during the final phase of testing incorporating the complete ATV prototype.

For almost half of the test locations, impulse noise ranging from moderate to extremely strong was observed and NTSC performance was severely impaired. Although the ATV system fared significantly better than NTSC under the impulse noise conditions, a true comparison of VHF performance (i.e., normal operating environment) by the two systems was not feasible. Spectrum analyzer display of the impulse noise showed it to vary from sharp spikes to fairly broad pulses; however, all demonstrated the 120-Hz repetition rate characteristic of the positive and negative maxima of a 60-Hz signal. Locations of particularly strong impulse noise are to be compared with the Charlotte-area power grid to determine whether or not correlation appears.

With no regularly assigned channel 6 television broadcast station in the Charlotte vicinity, the inhibitions against placement of noncommercial FM broadcast stations are not present. Consequently, a number of FM broadcast stations in the 88.1 to 91.9-MHz band exist near Charlotte. At a few locations, adjacent channel interference was sufficiently high that channel 6 data could not be measured adequately.

Analysis of Test Results

As previously mentioned, a total of 199 measurement locations were selected for this program. Approximately two-thirds of the measurement locations were along eight carefully selected radials, extending to approximately 55 miles and permitting tests and observations on strong, moderate, and weak signals. The remaining one-third were relatively close-in measurements, referred to herein as grid and cluster measurements, where predicted signal levels are expected to be strong or moderate, and variations in signal levels are attributed usually to shadowing and reflections from foreground terrain and clutter near the receiving antenna installation. Data were collected on all 199 locations on channel 53; however, because of the complaints of interference within cable channel 6, only 169 locations were measured on channel 6.

For the purpose of this analysis, the BER is used as the principal measure of performance of the digital transmission system. It is assumed that a site achieving a BER of 3×10^{-6} or better has satisfactory reception. For NTSC, however, the gradual degradation of NTSC performance makes difficult the determination of a threshold at which the NTSC reception is not satisfactory. For this analysis, however, a subjective yardstick was selected (CCIR impairment rating 3 or better) to define satisfactory performance for NTSC.

To evaluate the performance of the 8-VSB system in the field, the analysis was divided into two parts. The first portion examined the ATV service performance relative to NTSC, and the second examined the performance of the ATV system itself. The evaluation was conducted using a number of standard parameters commonly used in field test analysis.

Service Availability

Overall NTSC Service Availability

To assess the overall service availability within the predicted NTSC service area, a subjective evaluation method was used. This consisted principally of visual evaluation of the received television picture by two expert observers, who rated the over-

all picture quality using a CCIR impairment scale and Expert Commentary and Observations (EC&O) to evaluate audio degradation.

To rate the signal quality and impairment level, each expert observer evaluated the image and sound quality, then arrived at a rating by consensus. Assessment was made to the nearest half-step on the five-point scale, an acceptable practice in CCIR studies. Table 1 presents the impairment statistics for both channels (6 and 53) for all the measured locations. In all of the tables shown, the combined grid, cluster, and radial measurements were included in the tabulation of the impairment statistics, and the sample size is 169 sites for channel 6 and 199 for channel 53.

The statistics in Table 1 reveal that picture impairments were far more frequent in VHF than UHF. This unanticipated result is believed to be attributable to the prevalence of high impulse noise within the service area, the presence of co-channel interference from distant stations, low-level interference from cable installations on channel 6, and/or the interference to channel 6 reception from close-by noncommercial educational FM stations.

Overall ATV Service Availability

Unlike NTSC, the overall service

availability of the ATV system within its predicted service area can be determined with great accuracy, since the ATV picture is lost below a certain threshold level. This threshold level was previously determined to correspond to a BER of 3×10^{-6} . Table 2 presents the percentages of all the ATV measurement sites that are less than and greater than the threshold level.

A review of the ATV service availability statistics in Table 2 reveals that the overall service availability is higher for UHF than for VHF. Here again, these unanticipated results are believed to be attributable to the prevalence of high impulse noise within the service, the presence of co-channel interference from distant stations, low-level interference from cable installations on channel 6, and/or the interference to channel 6 reception from close-by noncommercial educational FM stations.

Comparison of Overall NTSC and ATV Service Performance

As stated earlier, CCIR grade 3 or better was selected as the criterion for satisfactory NTSC reception, while a BER of 3×10^{-6} or less is considered as satisfactory reception for ATV. Table 3 presents the percentage of locations, NTSC and ATV, where satisfactory reception was achieved for both channels.

The service performance statistics in Table 3 show that the ATV service performance statistics for channel 53 are moderately higher than for NTSC and substantially better than NTSC for channel 6. The data also show that the service availability for both NTSC and ATV is far better on channel 53 than channel 6. Here again, the prevalence of high impulse noise within the service area, the presence of co-channel interference from distant stations, low-level interference from cable installations on channel 6, and/or the interference to channel 6 reception from close-by noncommercial educational FM stations are believed to produce the unanticipated results.

Comparison of ATV and NTSC Service Availability for Grid and Radial Measurements

As noted earlier, the grid and cluster measurements were collected primarily to evaluate signal level variations usually attributable to shadowing and reflections from foreground terrain and clutter. By separating the data into grids and radials, ATV and NTSC service performance under these propagation conditions can be determined and compared. Tables 4 and 5 present the service availability, NTSC and ATV, for the grid and radial measurements of channels 6 and 53, respectively.

Tables 4 and 5 show that service performance for the grid measurements for ATV is somewhat better than for NTSC. Apparently, the ATV system is capable of dealing adequately with signal variations from location-to-location (i.e., location variability).

Comparison of ATV and NTSC Service Availability vs. Distance

To evaluate service availability under different signal level conditions, (i.e., strong, moderate, and weak), ATV and NTSC measurements were grouped in 10-mile increments and sorted by increasing distance. Tables 6 and 7 present a comparison of the service availability versus distance between NTSC and ATV on channels 6 and 53, respectively. The data in Tables 6 and 7 illustrate

Table 1 — Overall Impairment Assessment of NTSC Measurement Sites

CCIR Impairment Scale	Channel 6 (%)	Channel 53 (%)
5 Imperceptible	2.4	3.5
4 Perceptible, but not annoying	13.0	52.3
3 Slightly annoying	24.2	20.6
2 Annoying	27.2	14.5
1 Very annoying	33.2	9.1

Table 2 — Overall Service Availability of ATV Measurement Sites

ATV Service Availability	Channel 6 (%)	Channel 53 (%)
BER < 3×10^{-6}	81.7	91.5
BER > 3×10^{-6}	18.3	8.5

that the service performance versus distance is moderately better for ATV than NTSC, with a significant improvement occurring between 30 and 50 miles.

ATV System Performance

The data collected for ATV included a number of parameters that are useful not only in evaluating ATV service availability but also in determining the performance of the ATV system under various interference and impairment conditions. For example, equalizer tap energy statistics show how hard the equalizer is working to correct for varying signal levels and multipath conditions; ATV margin data tell how far the signal level may vary before ATV reception is lost; and changes in ATV noise floor, CNR, etc., provide the performance of the ATV system under various impairment conditions (co-channel, impulse noise, multipath, etc.). Of these parameters, margin data are most significant from a service viewpoint. Data relative to margin follow.

ATV margin is the measure of how far signal level can fall before the picture and sound are lost to the viewer. Since signal level at the receiver varies with location, time of day, season, and meteorological factors, the magnitude of the margin is a direct indicator of service reliability. Of course, signal level variability affects NTSC as well as ATV; therefore, an interesting parameter is the amount of ATV margin corresponding to the NTSC impairment rating.

To determine the ATV margin statistics corresponding to the various CCIR impairment ratings obtained from the NTSC service availability analysis, measurements at locations where ATV reception was satisfactory ($BER < 3 \times 10^{-6}$) were grouped according to the corresponding NTSC CCIR impairment ratings at the same locations. Then the median ATV margin and standard deviation were determined for each corresponding NTSC impairment rating. Tables 8 and 9 present the margin statistics for channels 6 and 53, respectively. (Channel 53 margin standard deviation for CCIR rating 1 is considered unreliable because of the small sample size, $n = 5$).

Table 3 — Relative Service Performance of NTSC and ATV

Service Performance	NTSC		ATV	
	Ch. 6 (%)	Ch. 53 (%)	Ch. 6 (%)	Ch. 53 (%)
Locations with satisfactory reception	39.6	76.3	81.7	91.5
Locations without satisfactory reception	60.4	23.7	18.3	8.5

Table 4 — ATV and NTSC Service Availability for Grid and Radial Measurements (Channel 6)

Measurement Locations	Number of Sites Measured	NTSC Sites CCIR 3, 4, & 5	ATV Sites BER < 3×10^{-6}
Charlotte grid and cluster	33	21	32
Rock Hill grid and cluster	9	3	8
Radial	127	43	98
Total	169	67	138

Table 5 — ATV and NTSC Service Availability for Grid and Radial Measurements (Channel 53)

Measurement Locations	Number of Sites Measured	NTSC Sites CCIR 3, 4, & 5	ATV Sites BER < 3×10^{-6}
Charlotte grid and cluster	33	28	31
Rock Hill grid and cluster	33	27	31
Close-in cluster	5	5	5
Radial	128	92	115
Total	199	152	182

Table 6 — Relative Service Performance for NTSC and ATV vs. Distance (Channel 6)

Distance (miles)	Number of Sites Measured	NTSC sites CCIR 3, 4, & 5	ATV Sites BER < 3×10^{-6}
0 to 9.9	27	18	26
10.0 to 19.9	38	26	37
20.0 to 29.9	33	14	31
30.0 to 39.9	28	4	25
40.0 to 49.9	28	5	16
50.0 to 55.9	15	0	3
Total	169	67	138

Table 7 — Relative Service Performance for NTSC and ATV vs. Distance (Channel 53)

Distance (miles)	Number of Sites Measured	NTSC Sites CCIR 3, 4, & 5	ATV Sites BER < 3 x 10 ⁻⁶
0 to 9.9	32	28	31
10.0 to 19.9	38	37	37
20.0 to 29.9	51	45	50
30.0 to 39.9	34	20	31
40.0 to 49.9	28	18	24
50.0 to 55.9	16	4	9
Total	199	152	182

Table 8 — ATV Margin Statistics vs. CCIR Impairment Rating (Channel 6)

CCIR Impairment Scale	No. of ATV Sites BER < 3 x 10 ⁻⁶	ATV Margin (dB)	
		Median	Std. Dev.
5 Imperceptible	4	43.7	4.51
4 Perceptible, but not annoying	22	38.2	7.40
3 Slightly annoying	41	25.6	9.73
2 Annoying	43	16.9	7.23
1 Very annoying	28	15.0	8.0

Table 9 — ATV Margin Statistics vs. CCIR Impairment Rating (Channel 53)

CCIR Impairment Scale	No. of ATV Sites BER < 3 x 10 ⁻⁶	ATV Margin (dB)	
		Median	Std. Dev.
5 Imperceptible	7	41.2	8.26
4 Perceptible, but not annoying	104	32.4	9.77
3 Slightly annoying	40	19.9	11.06
2 Annoying	26	7.7	7.7
1 Very annoying	5	19.7	14.13

Conclusion

For the entire sample of 169 for VHF and 199 for UHF, satisfactory VHF NTSC reception was found at only 39.6% of the locations, compared to 81.7% for ATV reception. Satisfactory UHF NTSC reception was found at 76.3% of the locations, compared to 91.5% for ATV. The relatively poor performance of the VHF signals relative to UHF is believed to be attributable to the prevalence of high impulse noise within the service area, interference from distant co-channel stations, the presence of low-level interference from cable use of channel 6, and/or interference to channel 6 reception from close-by noncommercial educational FM stations.

ATV performance was somewhat better than NTSC performance at all distances from the transmitter. For the entire range of distances, and for all sites where observations and measurements were made, 82% of the locations demonstrated satisfactory ATV results on channel 6, contrasted with 40% for NTSC. On channel 53, it was shown that at 91% of the sites ATV reception was expected to be satisfactory, compared to 75% for NTSC. At the outermost portions of the radials, beyond 50 miles, 2 of a total of 15 sites demonstrated satisfactory reception for ATV on channel 6, but none of the 15 had NTSC service with a CCIR impairment grade of 3 or better. For the same points beyond 50 miles, 9 of the 16 sites had satisfactory UHF ATV reception, compared to only 3 of the 15 sites with satisfactory NTSC reception.

Acknowledgments

The field testing project was well served by many dedicated persons. Especially to be acknowledged for their contributions are: Edmund Williams, project manager; Lanny Nass, field truck supervisor; Peyton Hines, transmitter supervisor; and Zenith engineers Richard Citta, Leif Otto, and Gary Sgrignoli. Public Broadcasting Service (PBS) provided management services, and the Association for Maximum Service Television, Inc. (MSTV) provided the data analysis.

The ATV margin statistics in Tables 8 and 9 show that, where the NTSC signal has a CCIR impairment rating of 3, the median ATV margin is 25.6 dB with standard deviation of 9.73 dB for channel 6, and margin and standard deviation for channel 53

of 19.9 dB and 11.06 dB, respectively. These figures provide ample ATV margin for locations where NTSC has a CCIR rating of 3. Furthermore, channel 6 also exhibited acceptable margin for locations where NTSC had a CCIR rating of 2.