

Approaches to Planning and Deploying MRC's Innovative Dual (Analog and Digital) Carrier Microwave System

By David Glidden

Microwave Radio Communications' (MRC) TwinStream radio is the first dual carrier radio for transmission of uncompressed legacy NTSC plus ATSC signals in a single 25-MHz radio frequency (RF) channel. Featuring a proprietary, patent-pending approach to microwave system design, the TwinStream radio is ideal for studio-to-transmitter links (STLs), transmitter-to-studio links (TSLs), and satellite backhaul requirements. MRC has worked closely with major network broadcast groups to provide the TwinStream radio for the November 1998 digital television (DTV) sign-on requirements. MRC's support of these demanding new applications is the latest in its long history of providing market innovations for television broadcasting. The TwinStream radio also is ideal for digital and analog programming feeds to cable headends and digital and analog newsgathering backhauls.

As television broadcasters deploy the infrastructure for their new digital television (DTV) channels, a pressing issue is the availability of radio frequency (RF) channels to support the studio-to-transmitter link (STL). One approach that early adopters have used is to compress the analog component signal using MPEG-2 techniques, and then multiplex that datastream (typically 15 to 20 Mbits/sec) with the ATSC (Advanced Television Standards Committee) transport stream (at 19.39 Mbits/sec). The combined transport stream is readily accommodated within a 44.736 Mbit/sec DS3 microwave link. Microwave Radio Communications (MRC) offers the DAR45 microwave radio system and the QM4 modems to upgrade fixed link heterodyne-digital/analog radios for these applications.

Another approach is to use previously underutilized spectrum for either the ATSC or the NTSC STL, such as the

17.7 to 19.7-GHz band. MRC offers the DMR-18 digital or analog microwave radio for these applications, as well as the DAR20 microwave radio, which provides a dedicated 19.39 Mbits/sec (plus "wayside" DS1 channel) in the 2, 7, and 13-GHz bands.

Each of these approaches is valid, but the compressed NTSC approaches entail increased system cost, complexity, and latency (video and audio processing delays). The additional RF channels approach is straightforward, but less conserving of RF spectrum.

Addressing these concerns, MRC has developed an innovative dual carrier radio system, the TwinStream Analog and Digital Microwave Radio System. Through a thorough system design using the latest filtering, frequency conversion, microwave sources, and modulation approaches, MRC has created a radio system that can be deployed within existing 25-MHz channels (at 6.8 to 7.1 or 12.7 to 13.2 GHz) and carry both NTSC and ATSC programming in their native transport stream formats (composite analog for the NTSC, 19.39 Mbits/sec for the ATSC). In addition, the 19.39 Mbit/sec modem also incorporates a DS1 (1.544 Mbit/sec) data channel that can be used for highly com-

pressed video, data broadcasting, second audio programming (SAP), an aural STL, local area network (LAN) traffic, or multiple voice channels.

Unlike some possible "add-on" approaches that assume that existing analog STLs can be retuned lower in the same channel band, tightly filtered, and then have a digital radio combined at RF in the waveguide, the MRC TwinStream solution is completely engineered. With the TwinStream, both RF chains (analog and digital) with their modulators or demodulators can be completely enclosed within one three-rack-unit-high transmitter or receiver.

Two Channels through the TwinStream Transmitter

As a total system design, the TwinStream incorporates both the analog (NTSC) and digital (ATSC) RF paths in a single RF shelf. The transmitter can be equipped with both analog and digital modulators, or accept a direct intermediate frequency (IF) connection from a separate modulator, or as a drop and insert if used as a multi-hop configuration.

In MRC's patent-pending design (Figs. 1 and 2), the IF signals from the analog and digital modulators are offset in frequency, and then mixed with separate local oscillators to create the specified output frequency. Each signal is then amplified and passed to the RF combiner, where the two channels are mixed and then fed to a single waveguide connection to the transmit antenna. Unlike add-on techniques, the TwinStream requires only normal waveguide connections and a single polarity antenna.

Receiving the TwinStream Signal

With the TwinStream receiver, both the analog (NTSC) and digital (ATSC) circuitry can be contained within a

Presented at the 140th SMPTE Technical Conference (paper no. 140-18), in Pasadena, CA, October 28-31, 1998. David Glidden is with Microwave Radio Communications, Chelmsford, MA 01824. An unedited version of this paper appears in *DTV Reality Check—The First Year*, SMPTE, 1998. Copyright © 1999 by SMPTE.

APPROACHES TO PLANNING AND DEPLOYING MRC'S INNOVATIVE DUAL (ANALOG AND DIGITAL) CARRIER MICROWAVE SYSTEM

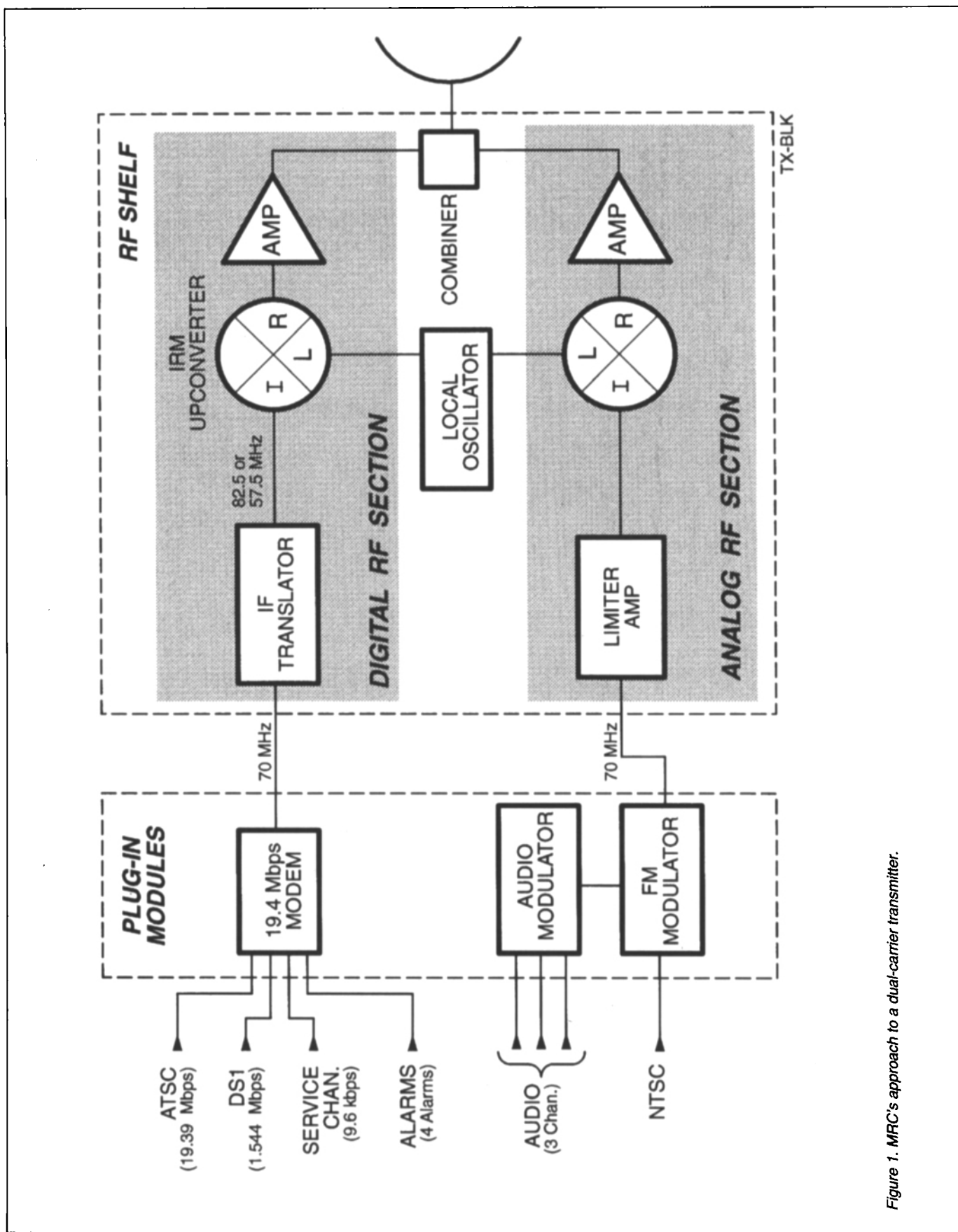

Figure 1. MRC's approach to a dual-carrier transmitter.

APPROACHES TO PLANNING AND DEPLOYING MRC'S INNOVATIVE DUAL (ANALOG AND DIGITAL) CARRIER MICROWAVE SYSTEM

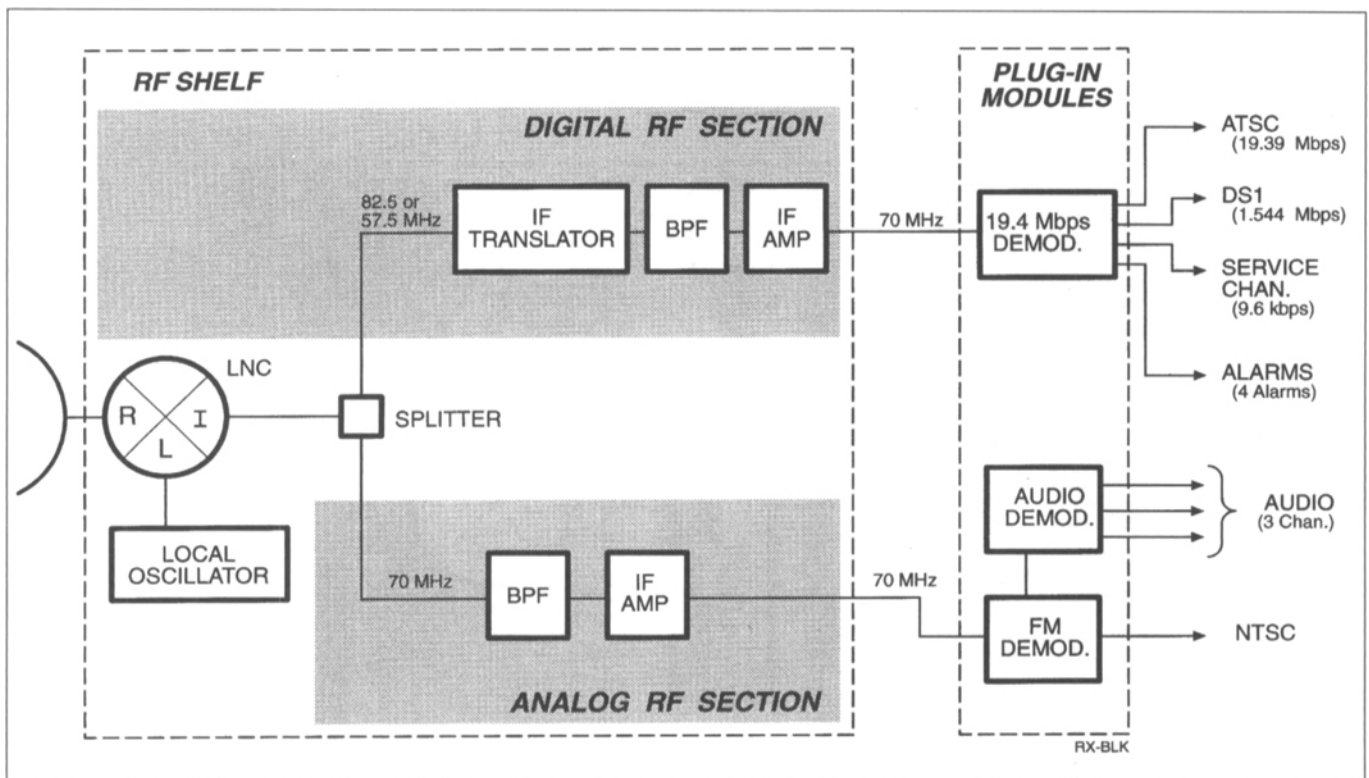

Figure 2. MRC's approach to a dual-carrier receiver.

single radio shelf. The receiver can be equipped with both analog and digital demodulators or accept a direct IF connection from a separate demodulator if used as a drop and insert radio in a multi-hop configuration.

From the receive antenna (Fig. 2), the two-channel RF signal is routed to the radio through waveguide, and then enters the low noise converter (LNC). The output of the LNC is split and sent to two IF sections, one analog and one digital. The digital IF, which had been offset in the transmitter from the analog IF, is then converted to a normal IF of 70 MHz before feeding the digital demodulator. Both the analog and digital IF channels are filtered and amplified prior to being demodulated by separate analog and digital demodulators.

Each of these modems then output a standard transport stream: analog NTSC and 19.39 Mbit/sec ATSC, for feeding the analog and digital broadcast transmitters. In addition, the digital demodulator outputs a 1.544 Mbit/sec (DS1) channel that can feed a radio transmitter or provide other voice or data traffic to the transmitter site.

System Gain Considerations in Developing System Link Budget

Planning for any new microwave system installation includes developing the system link budget for the microwave path. When the TwinStream radio is replacing an existing analog microwave system, it is important to analyze each element of the RF chain, including waveguide and antennas. It is also important to model the digital signal to ensure that the 19.39 Mbit/sec ATSC transport stream will have sufficient system gain.

Compared with the analog part of the radio link, the ATSC transport stream is modulated by 16-level quadrature amplitude modulation (16QAM) techniques, requiring a more linear signal than the analog channel. With the reduced power output created by linearizing the power amplifier and the reduced receiver sensitivity of a digital design, the TwinStream (consistent with any digital radio design) offers ~8 dB less system gain than the analog channel. Typical approaches to overcoming this reduced system gain include increasing antenna sizes, upgrading antenna and waveguides to

minimize voltage standing wave ratio (VSWR) losses, and adding a diversity receive system. It should be noted that the digital signal is usable up to its threshold, whereas an analog signal may not be. This must be accounted for when considering the reduced system gain of the digital design.

Using the TwinStream for Satellite and Electronic News Gathering (ENG) Backhauls

As television stations start their transition to digital broadcasting, the studio-to-transmitter link is just one area where the innovative dual-carrier TwinStream radio makes sense. Where the network programming satellite receive site is not co-located with the TV studio, it may be necessary to combine both NTSC and ATSC programming feeds on the same TSL or backhaul link.

There are three different scenarios in which the TwinStream can be used for this requirement:

1. Configure the TwinStream identically as for the STL, that is, with the analog NTSC carrier and a 19.39 Mbit/sec ATSC carrier. This scenario, of course, would require either network

transport of the 19.39 ATSC transport stream or placement of an ATSC encoder at the transmitter site to reduce a higher bit rate network program stream to the 19.39 Mbit/sec transport stream rate.

2. Convert the "analog" carrier of the TwinStream to a 45 Mbit/sec (DS3) digital carrier by the addition of the QM4 16QAM modulator and demodulator, with corresponding linearization of the 45 Mbit/sec carrier RF channel. In this scenario, the network program feed of the ATSC programming at DS3 rates would be transmitted through the broader, 45 Mbit/sec RF channel. The analog NTSC programming would be encoded and compressed, using a product such as the MRC MediaMux MPEG-2 encoder, and placed on the narrower 20 Mbit/sec RF channel.

3. Use the "Analog + DS3" version of the TwinStream, with a full 44.736 Mbit/sec datastream on the narrower digital RF channel, rather than the 19.39 Mbit/sec datastream. In this configuration, a higher order modulation rate (128QAM) is used, at a reduced system gain. For this reason, great care must be used in profiling the digital link performance for this option.

The TwinStream is an ideal "evolutionary" approach to digital ENG as well. Due to pending changes in the 2-GHz broadcast auxiliary band, broadcasters are anticipating converting to digital modulation techniques as a way to accommodate narrower RF channels. During a transition phase from analog to digital ENG, it may be desirable to have both analog and digital newsgathering taking place simultaneously. The TwinStream, then, is the ideal way to backhaul analog and digital ENG signals from a remote central receive site.

Other potential applications for the TwinStream include feeding both ATSC and NTSC programming channels to cable headends, translators, and to TV studios or transmitters in an adjacent market.

Planning for a Digital Future: Upgrading from Analog Plus Digital to Fully Digital

The TwinStream is designed to provide reliable service for years to come,

which means that a time may come when the analog carrier portion of the radio link is no longer needed. At that point, the TwinStream user will have three major options for adapting the TwinStream to a fully digital environment:

1. Remove the analog radio and use the TwinStream as a 7.5-MHz wide STL for the DTV channel only.

2. Replace the analog modulator and demodulator with digital modems, with some adjustment to the RF signal chain to linearize the power output and eliminate the AM limiter. This second DTV channel can be used as a backup, to feed a second DTV channel, or for other yet unplanned digital transport requirements.

3. Replace the digital modems on both sides of the radio with a wider bandwidth modem, such as the MRC 45 Mbit/sec QM4 modem. This approach could be used to transport a less compressed digital video contribution stream prior to creating the ATSC distribution transport stream of 19.39 Mbits/sec.

As a comprehensive STL solution, the TwinStream offers more than a migration to DTV transport today. It provides an evolutionary approach to DTV standards today and in the future.

Why TwinStream Is a Better Approach to Analog Plus Digital

When the FCC allocated one new DTV channel for each existing NTSC channel, it did not create additional RF spectrum to support microwave STLs. With the TwinStream, the 19.39 Mbit/sec ATSC transport stream, a DS1, and a service channel can be modulated and transported alongside a conventional analog video stream within a standard 25-MHz STL channel. Because the dominant RF component of the TwinStream is the analog carrier, the TwinStream is licensable under standard analog STL procedures for the 6.8 to 7.1-GHz and 12.7 to 13.2-GHz broadcast auxiliary bands.

Of course, there are alternatives to the TwinStream:

1. Digitize and compress the analog NTSC programming for multiplexing, through a product such as the MRC MediaMux, with the ATSC transport stream, at increased cost over the

TwinStream solution.

2. Retune an existing analog FM radio and add a new 19.39 Mbit/sec interface radio through exacting filtering and waveguide combining, at increased complexity and risk over the TwinStream approach.

3. Lease fiber-optic services for the DTV STL, with increased, recurring operating costs over the TwinStream radio.

Depending on the implementation strategies and requirements of the individual broadcaster, each of these alternatives to the TwinStream may make sense. For the overwhelming majority of broadcasters, however, the TwinStream offers outstanding value and a low-risk way of adding DTV programming to an existing analog microwave path.

THE AUTHOR

David Glidden is vice-president and general manager for broadcast video products at Adaptive Broadband Corp. (formerly California Microwave, Inc.) in Billerica, Mass. He has served in marketing, product-line management, and business development roles, since 1991, for the MRC business unit and its predecessor company, Microwave Radio Corp. Before joining MRC, Glidden was a partner in a technology-focused marketing consulting firm in Massachusetts and New Hampshire, and a marketing manager for electronics firms in Arizona, California, and Washington.

Glidden started his career in television production management with the U.S. Army Signal School, American Forces Television-Germany, and Nebraska Public Television. He holds a master's degree in business administration from Arizona State University, a master's degree in public administration from the University of Nebraska, and a B.S. in speech degree from Northwestern University.
