

# Automatic Luminance Tuning for High Intensity Xenon Lamp Consoles in Motion Picture Film Projection

By Mark C. Regel

*This paper details a method of automatically aligning high intensity xenon lamps, in three motorized axes within lamphouse reflectors, to optimize luminance distribution on motion picture screens. The existing methods of adjusting luminance distribution, visual or spot-metering, are highly operator dependent and often produce less than optimum results. In addition, the somewhat tedious process of spot-metering often leads to a compromise in lamp alignment, between flat and scope formats being used. The automatic method of alignment, detailed within this paper, incorporates solid-state electronics and charge-coupled device (CCD) optics to provide quick, repeatable and optimal luminance distribution in any format and includes compensation for the vertical angle between the projector to screen light path and the screen-to-audience light path.*

Modern film print stock used in general cinema has been optimized to produce the best quality color reproduction at a luminance of approximately 16 fL. If less than optimum luminance is obtained, the screen may display a picture with color that appears dull and washed-out. On the other hand, if excessive or inconsistent luminance is achieved, some viewers may notice a change or flicker in the brightness level. Thus, it is important that the screen luminance is optimum and consistent across the entire screen area.

A number of factors may detract from this optimum level of luminance distribution, including misalignment of the lamp housing, with respect to the projector optics; variations between the characteristics of replacement lamps and those originally supplied; positioning of the projector, with respect to the viewing audience; and changes between film formats.

Historically, adjustment of the light source has been performed manually, either through a visual inspection of the projection screen or use of a

reflected light spotmeter. In either case, these manual adjustments require skilled personnel, precise equipment, and significant time. In cases where projection screens possess directional characteristics, the task of tuning the light source is complicated by the vertical separation of the viewing position of the audience from the light source position where adjustments are usually made.

The previous case is an example of a condition that remains relatively stable for the life span of the bulb; the changing of film formats presents a more challenging problem. As most light sources used in film projection produce a beam of light with a circular cross section, some of the lamp's energy is blocked by the aperture plate (Fig. 1). However, since the height-to-width ratio of the two most common 35mm film formats (flat and Cinema-Scope) is different, the best luminance distribution can only be obtained by adjusting the

bulb position with every format change. In practice, a compromise bulb position is usually selected, but as the size of cinema screens continues to increase while the maximum film operating temperature remains comparatively constant and visual detracting from using high-gain screens continues to be an issue, the need exists for a simple, fast, and reliable method to optimize the light source.

## Details

The UltraFocus lamp alignment system, jointly developed by Christie Inc. and USL, quickly and accurately measures the luminance distribution of light on the cinema screen so that the position of the lamp can be adjusted automatically to obtain the best distribution. This is achieved by using a light receiver aimed at the screen from within the auditorium or in the projection booth of a theater (Fig. 2); an analyzer and control unit (ACU) to determine the luminance levels and generate control outputs; and a motorized lamp positioning system. The light receiver incorporates a CCD camera that typically has a zoom lens with at

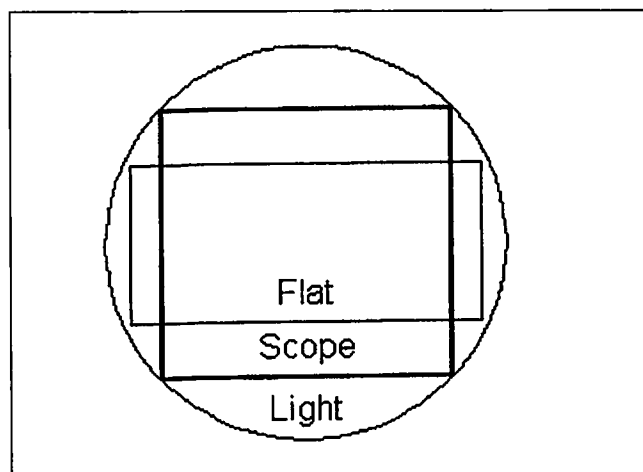

Figure 1. Film formats.

Presented at the 140th SMPTE Technical Conference (paper no. 140-44A), in Pasadena, CA, October 28-31, 1998. Mark C. Regel is with Christie Inc., Cypress, CA 90630. An unedited version of this paper appears in *DTV Reality Check—The First Year*, SMPTE, 1998. Copyright © 2000 by SMPTE.

## AUTOMATIC LUMINANCE TUNING FOR HIGH INTENSITY XENON LAMP CONSOLES IN MOTION PICTURE FILM PROJECTION

least a 4:1 zoom ratio. A separate photoelectric cell is collinearly mounted with the CCD camera to detect light reflecting from the screen.

While the projector light source is constant, the light emitted from the projector is not. The projector shutter interrupts the light path, twice for each frame for approximately two 10-msec pulses of light or at a rate of 48 Hz. In

order for each light pulse emitted from the projector to be entirely captured by a field scan of the light receiver, the receiver includes components that synchronize the field scan and the pulse train of the light source. Thus, the receiver is able to scan the screen at the same rate and phase as the light pulses emitted by the projection equipment (Fig. 3).

The receiver contains a sync and scanning pulse generator, which determines the rate and phase of each field scan of the receiver. While CCD cameras, such as the one used in the UltraFocus light receiver, usually employ crystals as a timing reference, the crystal in this system has been replaced by a reference oscillator as the basic timing block for the sync generator. This facilitates locking the camera into the same phase as the projector.

To achieve synchronization, after the photoelectric cell detects the light pulses from the screen, the pulses are amplified and filtered. The amplifier and filter have a frequency response that is sharply peaked at the frequency of the light pulse train emitted from the light source, to discriminate against light variations at other frequencies. This frequency is normally set at 48 Hz and facilitates discrimination against light variations at 60 Hz and 120 Hz.

To achieve optimal synchronization, the output of the amplifier and the filter are fed into a pulse shaper that converts the essentially sinusoidal output of the amplifier filter into a square

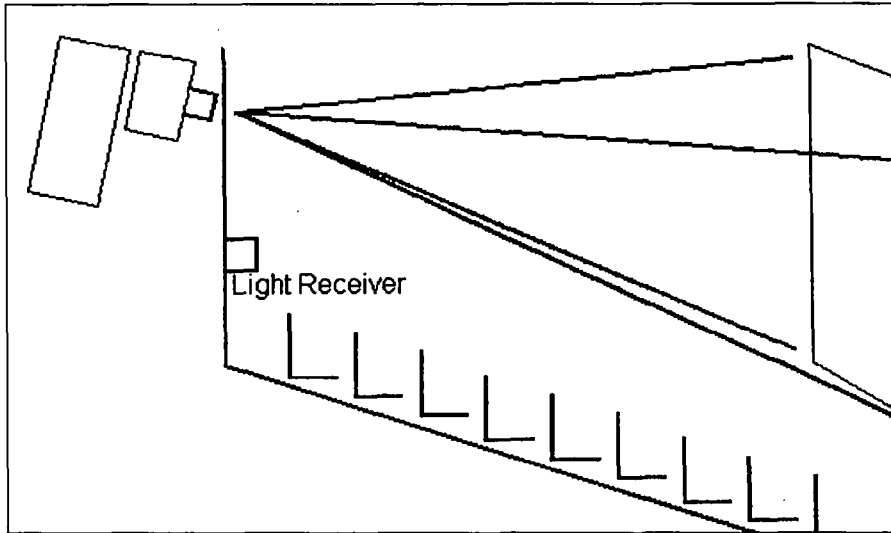

Figure 2. Equipment layout.

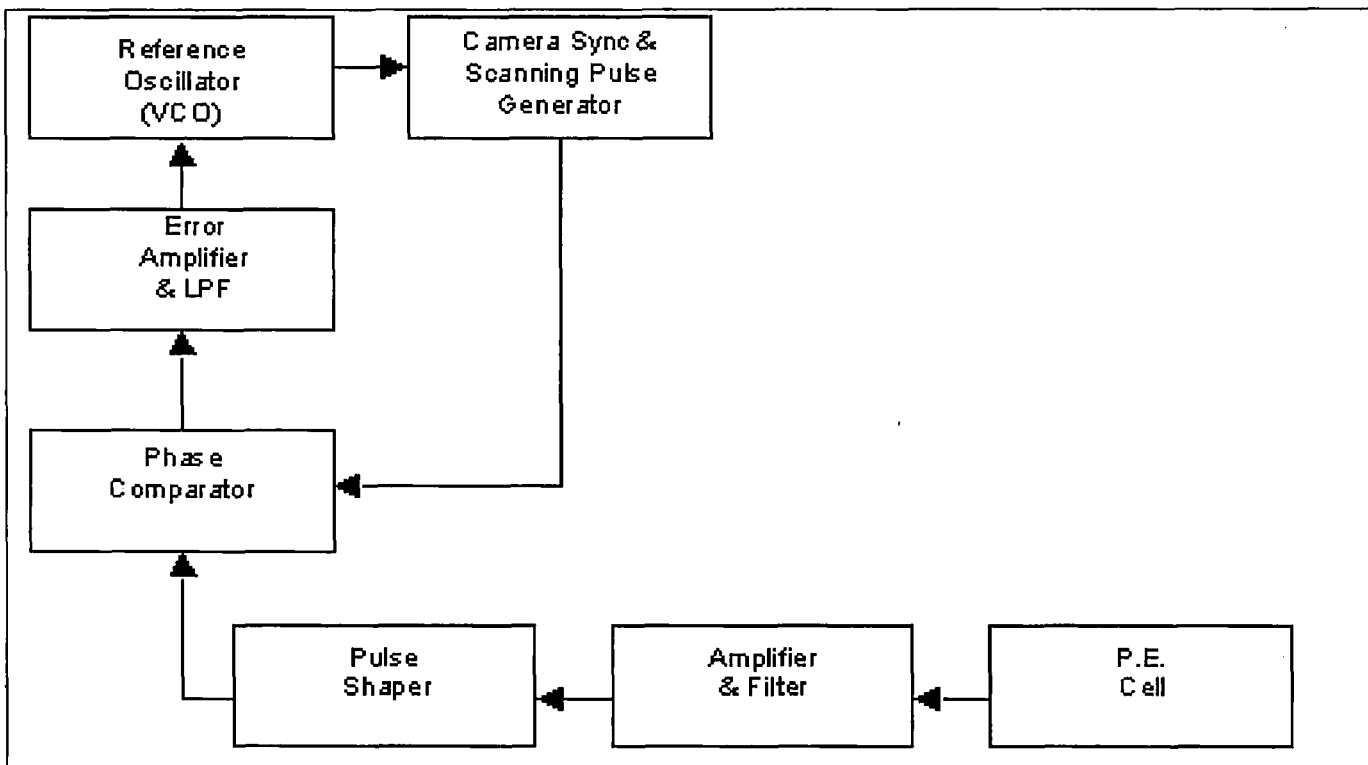

Figure 3. Synchronization block diagram.

## AUTOMATIC LUMINANCE TUNING FOR HIGH INTENSITY XENON LAMP CONSOLES IN MOTION PICTURE FILM PROJECTION

wave compatible with the input requirements of the phase comparator.

If a phase difference is detected, the phase comparator generates an error signal, which is amplified and filtered. This is then fed into the reference oscillator to vary the phase and/or frequency of the reference oscillator until the signal produced by the sync generator is phase-locked at the same rate and phase as the light pulses generated by the projector. Thus, when each light pulse of a 48-Hz train is emitted from the projector, it will be entirely captured by a field scan of the camera.

While it is preferable that the light receiver be synchronized with the light pulses reflecting off the screen, the ACU can also be used effectively without the light receiver being synchronized with the light pulses. If synchronization does not exist, the light receiver will also detect the time period between light pulses. Since luminance readings vary whenever the phase of the light receiver and the light pulses are out of sync, peak readings would have to be made, and the measurement process would be much slower.

The ACU captures and stores individual image frames detected by the receiver and can also measure and store selected pixel values within a frame. It is also able to average a number of pixel values within a selected area of an image. In addition, it corrects systemic errors such as variations in sensitivity of the light receiver and aberrations within the camera lens.

To close the control-loop, the projector lamphouse or console must be fitted with a motorized lamp position control system. This control system must be able to move the lamp relative to the fixed optical components such as the reflective mirror. In addition to being able to alter the light distribution in the horizontal (X) and vertical (Y) planes, the lamp position must be moveable in the Z or focus axis. A relay driver interface capable of activating the motor control relays in response to low-level control signals from the ACU must be provided.

### Operation

When measuring screen luminance, the projector and lamp are operated normally, except that the projector

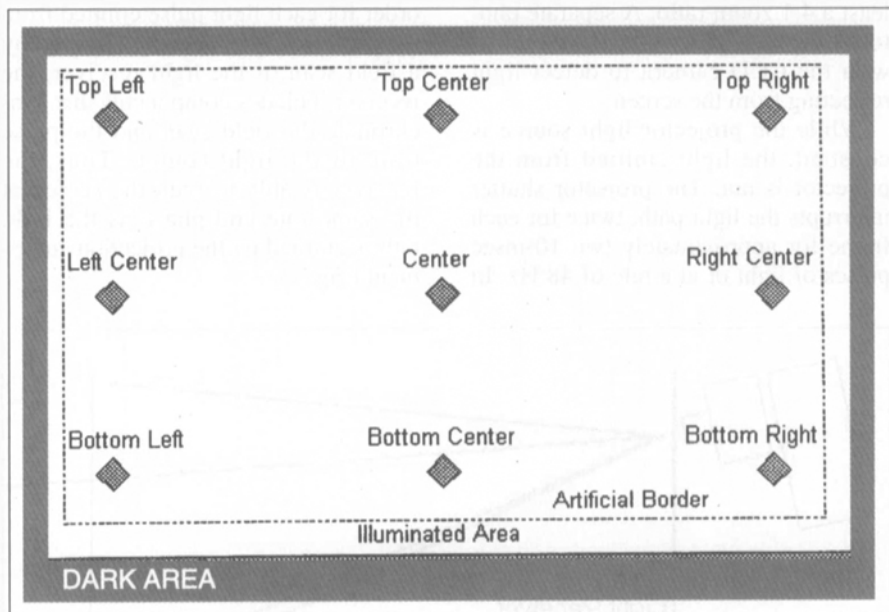

Figure 4. Screen borders and measurement points.

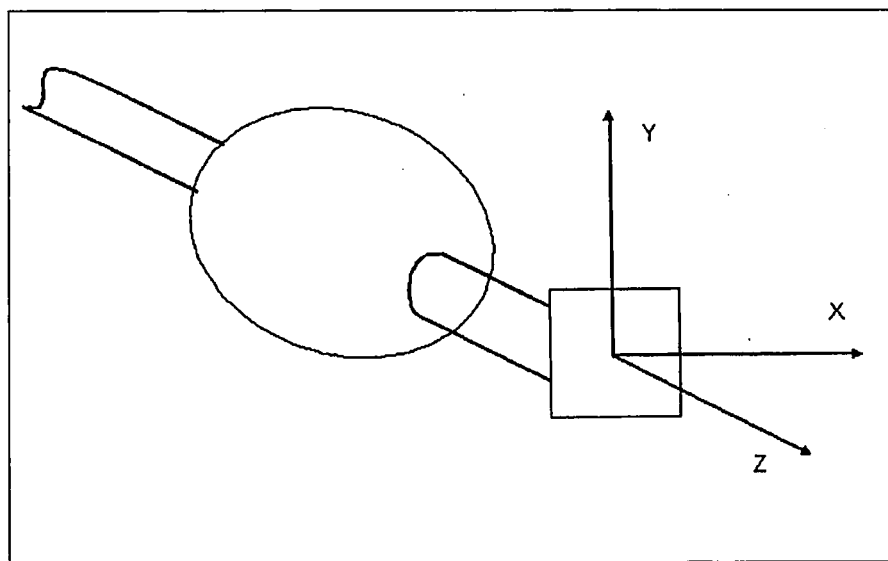

Figure 5. Motorized lamp adjustment.

does not contain any film. The extremely high level of energy generated by the lamp will heat the projection lens rapidly and may fracture it; therefore, any adjustment to the lighting source must be made quickly and for all three axes concurrently.

The CCD camera is mounted on the rear wall of the audience area of the theater and the zoom lens is set so that the camera overscans the theater screen. Processing electronics in the ACU detect the horizontal and vertical edges of the screen in the camera

image by constructing a histogram of the luminance values for the entire image. The histogram will detect two areas where the occurrence of the luminance values are concentrated. One is the dark area, where the luminance values represent image information from the low reflect area outside the screen boundary. Another is the light area, where the luminance values represent image information from the illuminated screen. The ACU then spatially analyzes the data to determine the screen boundaries and the

## AUTOMATIC LUMINANCE TUNING FOR HIGH INTENSITY XENON LAMP CONSOLES IN MOTION PICTURE FILM PROJECTION

luminance distribution on the screen.

Specifically, an artificial border is established within the screen image. Usually it is 5 to 10% smaller than the screen image to avoid severe light variations that may occur near the edges of the screen. All luminance measurements are made within these artificial borders.

The portion of the screen image within the artificial borders is divided into a selectable number of measurement points. Typically there are nine points located at predetermined distances from the screen border and the screen center: center, center top, center bottom, left, left top, left bottom, right, right top, and right bottom (Fig. 4). These points are assigned an average reference value according to previously measured illumination intensities. The ACU analyzes the screen luminance pattern by measuring the voltage of each pixel detected by the camera against a reference voltage, which is the voltage produced by a black level. Once this analysis is complete, the ACU generates control signals which are then transmitted to motorized lamp position actuators in the lamphouse or console (Fig. 5).

To center luminance distribution on the screen, the focus control in the lamp housing is adjusted until the luminance pattern shows significant darkening around the edges. The first moments of luminance of each of the scan lines are then taken horizontally and vertically repeatedly. They are then averaged to determine the horizontal and vertical location of the brightest area of the luminance pattern. This location is compared to the known actual physical center of the screen rectangle so that an error signal is generated to drive the X and Y motors in the lamp housing. This process is repeated until the luminance pattern is centered on the screen and there is only a slight fall-off in luminance (25% or less) near the corners.

To control the quality of the luminance, the system measures two parameters: total luminance, that is, the

total of all luminance values for the screen, and the corner-to-center ratio, that is, the average luminance in the corner regions of the screen divided by the total average luminance in the center of the screen.

A reference value is determined by a weighted average of the total luminance and corner-to-center ratio. Luminance distribution is adjusted by moving the focus motor until a very flat luminance distribution is achieved. The motor is then moved in the direction that produces progressively brighter and less flat luminance distributions. During this period, the reference value is continuously observed and compared with previous ones to locate a peak value. Once the peak value is ascertained, the location of the lamp for optimal luminance distribution has been obtained.

The centering and luminance distribution processes are somewhat user adjustable. For example, in image centering, the user can select a vertical offset to the nominal center location, to allow for differences between the point of view of the light receiver and the actual position of the movie audience when viewing a screen with

directional reflective characteristics. Depending on individual preference, the user can choose between several settings to maximize either the brightness or luminance distribution on the screen or to account for variations in projection angles and/or surface gain.

The software in the ACU contains predetermined compliance criteria that must be satisfied in order to terminate the system operation. If the criteria are not satisfied within a predetermined amount of time, the system will time-out, requiring the user to restart the software or physically reevaluate the system.

### Conclusion

The UltraFocus system automatically aligns high intensity xenon lamps within lamphouses or consoles. It achieves this by utilizing a CCD camera, light-pulse train synchronization, and three-axis motorized lamp actuators, providing optimal luminance distribution on motion picture screens in a rapid, reliable, and repeatable fashion. The system ensures that the movie-going public enjoys the highest quality image reproduction and visual cinema experience possible.

---

### THE AUTHOR

**Mark Regel** received master's degrees in business and technology, a graduate diploma and graduate certificate in industrial management, and a bachelor's degree in engineering.

As a project recovery specialist, Regel successfully concluded projects in defense, aerospace, petrochemical, heavy industry, and manufacturing sections.



He was the special projects engineering manager for Mobil Oil Australia Ltd. prior to joining Laservision (Australia) Pty. Ltd., where he managed the design, installation, and commissioning of theme park attractions around the globe.

In April 1998, Regel was recruited by Christie Inc. and relocated to Los Angeles, CA to manage the electronic projector group.

---