

The Technology of Enhanced Color Saturation

Kodak Ektachrome 100D color reversal film/5285

By David L. Long

The technology behind the enhanced color reproduction of Kodak Ektachrome 100D color reversal film/5285 will be outlined. Attention will be given to both the chemical and photophysical design considerations incorporated into the technology, as well as some of the benefits offered to its users.

Kodak Ektachrome 100D color reversal film/5285 was introduced to the motion picture market in December 1999. Its release marked the culmination of a number of years of work on the part of researchers in both Kodak's Color Reversal and Entertainment Imaging R&D groups. The design concept was to create a highly saturated color reversal film at an EI100 speed without compromising flesh and neutral reproductions.

A total of three films incorporating the high color technology have been introduced by Kodak: Professional Ektachrome film E100VS for the professional still photography market, Elite chrome extra color 100 film for the consumer still photography market, and Ektachrome 100D color reversal film for the motion picture market. A summary of general performance attributes of the three films can be found in Table 1. Table 2 shows the characteristic curve comparisons between camera positive 100D film and camera negative Eastman EXR 50D film/5245 printed to a positive on Kodak Vision color print film/2383 (the only fair sensitometric comparison of a negative film and a positive film requires the negative be printed).

This is an expanded version of a paper presented at the 142nd SMPTE Technical Conference (no. 142-30), in Pasadena, CA, October 18-21, 2000. David L. Long is with Eastman Kodak Co., Rochester, NY 14650. Copyright ©2001 by SMPTE.

Photographic Color Reproduction: The Basics

Before any discussion of the color enhancing technology incorporated into 100D film can begin, some background into the basics of color rendition theory in photographic systems are presented, starting with the very elementary representation of the photographic process in Fig. 1. This figure is designed generically to describe either a negative or positive image capture film, though more detailed differences between the two will be discussed later.

Here, the three primary components of visible light (red, green, and blue) reflected from a scene are captured in the red, green, and blue-sensitive layers of a silver halide photographic film; this process is known as latent image generation. The latent image consists of small silver particles formed within a silver halide crystal as a consequence of the reaction of silver halide with visible light. Once the film is developed through appropriate processing chemistry, the red, green, and blue-layer latent images are converted chemically into subtractive photographic dyes, cyan, magenta, and yellow, respectively. These three dyes are chosen because they are the spectral complements (or opposites) of the three primary additive light colors. The term subtractive refers to

Table 1—General Performance Attributes of the EKTACHROME 100D Film

Speed	True EI100
Best-Fit Gamma	1.6-1.7 (positive sensitometry) compared to 1.8-1.9 for a print from EXR 50D Film/5245
Sharpness	Acutance higher than any EI100 speed reversal product and similar to AMT ratings of an EXR 50D print
Grain	Comparable to other EI100 speed reversal products and advantaged over the EXR 50D print by 4.5 grain units
Reciprocity	No filter corrections required for exposures from 1/10,000 to 10 seconds
Raw Stock Stability	Comparable to any Kodak motion picture capture product
Color	High saturation of scene colors with accurate treatment of neutrals and flesh tones

Table 2—Characteristic Curve of EKTACHROME 100D film/5285 versus EXR 50D film/5245 printed on KODAK Vision Color Print Film/2383

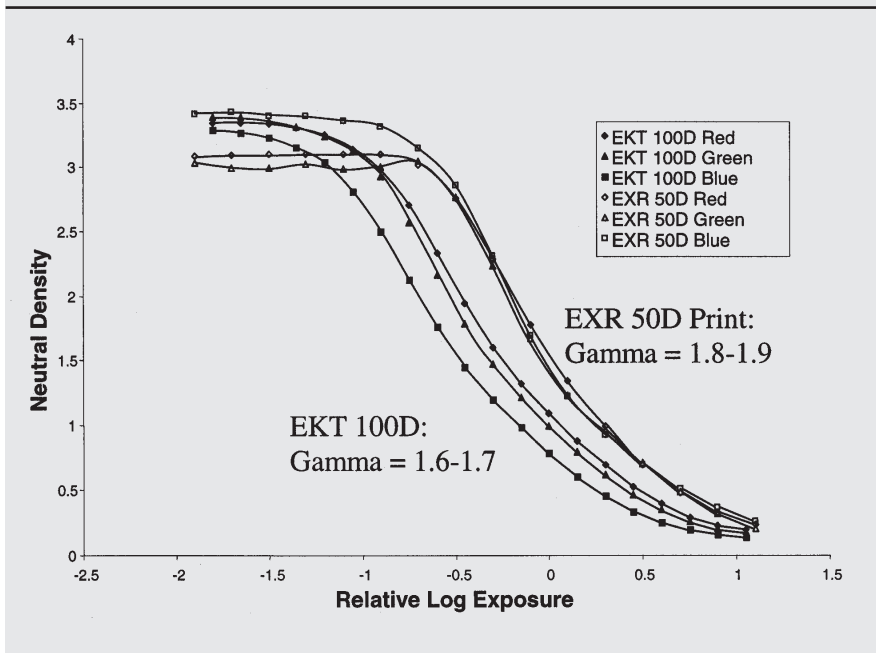

the action of the dyes removing certain spectral transmission from a white light source in order to modulate color.¹

In a negative-acting film, red light captured in the red-sensitive layer of the film will produce cyan dye; similarly, green light will induce magenta dye formation in the green-sensitive layer, and blue light will induce yellow dye formation in the blue-sensitive layer. A bleach step in the chemical processing must also be included to remove developed silver from the film, because a by-product of the dye-formation reaction is elemental silver at all of the latent image sites; a fix step completes the processing, removing unexposed silver halide from the film and stabilizing it against further exposure.

The subtractive complementary dyes in the capture negative are transferred or “printed” to a receiver piece of film, which is also negative acting. For example, imagine taking a picture of a red square. The red square is imaged in the red sensitive layer of the capture film and consequently cyan dye is formed in that layer. In printing, a white light is shone through the capture negative and onto a receiver film (the color print film). The cyan dye in the cap-

ture film absorbs its complement (red light) from the white source leaving only green and blue light incident upon the receiving film. These two colors of light will produce magenta dye and yellow dye, respectively, in the receiving film.

When this piece of film is projected using a standard white light source, the magenta dye absorbs its complement, green, and the yellow dye absorbs its complement, blue, from the projector source. What remains is only red light hitting the screen. As a result, what was a red

square in the scene appears as a red square now on screen.

In a positive film like 100D, the process is a bit more complicated. With no printing step involved, the red square must be imaged directly on the original piece of capture film as yellow and magenta dye, if it is to appear red when projected. In the reversal process, the red, green, and blue lights are still imaged in red, green, and blue-sensitive film layers; however, now instead of dye being formed in the layer that was specifically exposed at image capture, dyes are formed in the layers that were not exposed.

The secret lies in the processing chemistry. The first step in the reversal process takes the latent image signal and turns it into a negative black-and-white image (with relative exposure yielding a proportional amount of “black” silver); no dye is produced in this step. With that image formed, a second stage creates latent image in the unexposed portions of the film and turns this new image into colored dyes via the same route already described for color negative material. Consequently, any area of the film that was exposed to light has the black silver image but no dye, and any area that was not exposed to light has dye present (plus the aforementioned elemental silver by-product). The final stage of the chemistry removes all of the silver and silver halide from the film, leaving only dye in those areas not exposed.

In summary, the red square images

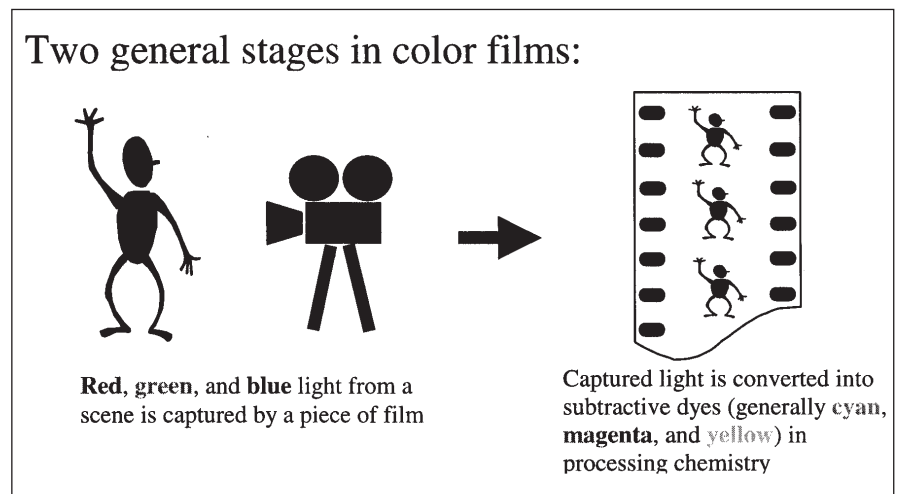

Figure 1. A simple representation of image capture.

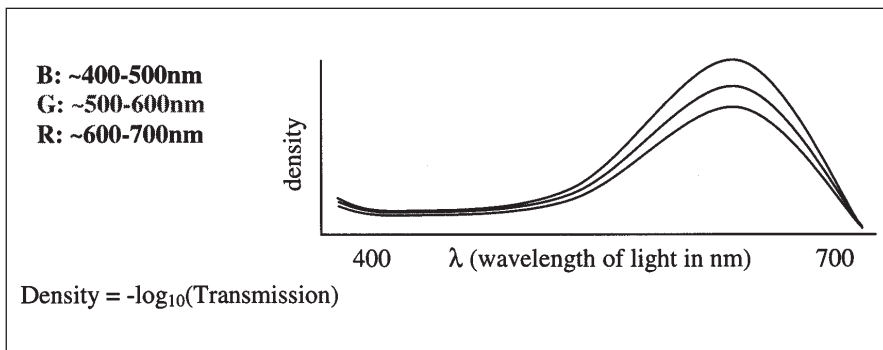

Figure 2. Typical spectral dye density curve for a photographic dye.

in the red layer of the film, but the reversal development process creates dye in only the unexposed green and blue layers (magenta and yellow dye).²

Photographic Color Reproduction: The Details

The two-stage picture of image formation described above is admittedly simplistic. The actual photo-physics involved in rendering the total visible color palette are decidedly more complicated. Still, the more in-depth details of color reproduction may be understood within the context of the two simple steps above, exposure and dye formation.

The Impact of Image Dyes

As already mentioned, subtractive dyes are intended to modulate color by controlling the transmission of specific spectral regions of the visible light scale. By considering the spectral modulation characteristics of each of the three dyes incorporated into a film (cyan, magenta, and yellow), we can begin to derive the range of colors that can be reproduced with these dyes, a concept known as color gamut.³

Color gamut calculations involve characterizing the specific spectral profile of each of the dyes in a film system and determining the colors that can be rendered with a given combination of those imaging species. The gamut of reproducible colors will include everything from the pure dyes, to combinations of only two of the three dyes, to various combinations of all three. The important point is that a dye system's color gamut is measured independent of how the dyes come to exist on a

piece of media. It is rather the theoretically ideal space of colors that can be represented by any mixture of the dyes.

To characterize the color of an individual dye, its spectrophotometry or spectral dye density must be determined. This is simply a measure of a dye's ability to transmit light at each of the wavelengths in the visible spectrum. Figure 2 represents a typical set of spectral density curves for a cyan dye.

Each curve offers information on how much light is absorbed by the dye in each of the three principal regions of the white light spectrum (blue at ~400 to 500 nm, green at ~500 to 600 nm, and red at ~600 to 700 nm). The three curves are also meant to represent the measurement at three different concentrations of dye; with more dye present, the density expectedly increases. It is important to note, however, that the increases at each wavelength are not proportional; in other words, real photographic dyes can change their transmission profile (and hence their color) depending on their concentra-

tion, something that has definite color reproduction consequences in a film system.

Once the spectrophotometry is measured, a set of calculations similar to those outlined by Hunt adhering to the CIE¹ standards will yield three color metrics: L*, a descriptor of a color's luminance or "lightness" from black to white; a*, a measure of a color's hue along a red-cyan axis; and b*, a measure of a color's hue along a yellow-blue axis. With these three terms, any color stimulus directly viewed by the eye can be described in terms of its hue and its lightness. The CIELAB color metrics are designed to establish a measurement of space that is approximately linear in perceived color differences. In other words, any two scene colors (or film dyes) mapped into the CIELAB coordinate system will henceforth be represented by a calculable difference in psychophysically perceived color.

Though this example refers to dye color characterizations, the CIELAB calculations allow the measurement of the color of any visible object with a specific spectrum. In order to calculate CIELAB coordinates for a real color patch in a scene, the illuminating source spectral power output is cascaded with the reflectivity of the scene patch to give the spectrum of light incident upon the eye. This spectrum is integrated with the eye's color-matching functions (a mathematical representation of the eye's spectral sensitivity) and converted into perceptual color metrics, L*, a*, and b*.

Returning to the discussion of pure photographic dyes, the CIELAB

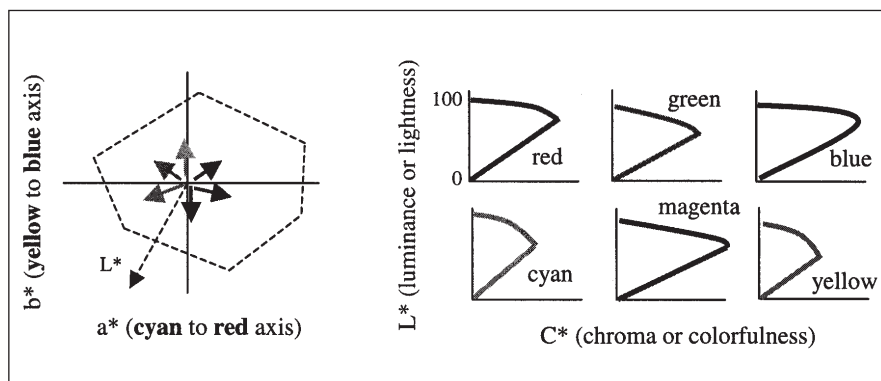

Figure 3. CIELAB color gamut representation of a theoretical photographic dye set.

color gamut for a dye set is established by calculating the $L^*a^*b^*$ locus for every possible combination of our dyes. The color gamut space is consequently three-dimensional, because three parameters are used to describe each color. Figure 3 shows one example of the way in which the CIELAB color gamut of a film can be represented. Even though CIELAB is a three-dimensional coordinate space, it is convenient to think of the color gamut in terms of the 2 two-dimensional plots shown.

In Fig. 3, the left plot shows three-dimensional color gamut projected onto the $a^* b^*$ hue plane. Every color perceivable by the eye is represented by some position on this plot (with the center representing the neutral tone scale); the L^* axis is shown perpendicular to the page on this plot just for proper perspective. The area within the dotted lines is the hue gamut of the dye system.

The diagram on the right in Fig. 3, shows color gamut from the perspective of the third CIELAB dimension, L^* . Here, the six primary hue directions (red, green, blue, cyan, magenta, yellow) from the $a^* b^*$ plot are chosen and a trace of L^* versus C^* is made (L^*C^* gamut). C^* is a measure of chroma or "colorfulness" and is exactly the linear difference between the origin gray and the actual hue coordinates on the $a^* b^*$ plot. This makes sense as the colorfulness can be thought of as the difference from gray for a specific lightness value.¹

The right plot, displays a characteristic triangular gamut for L^* versus C^* for each of the six primary hues. Any color at $L^*=0$ goes to zero chroma, because the definition of $L^*=0$ is absolute black (a shade of gray). The same argument explains why all of these plots also converge to zero chroma at $L^*=100$ (where the color is by definition a reference

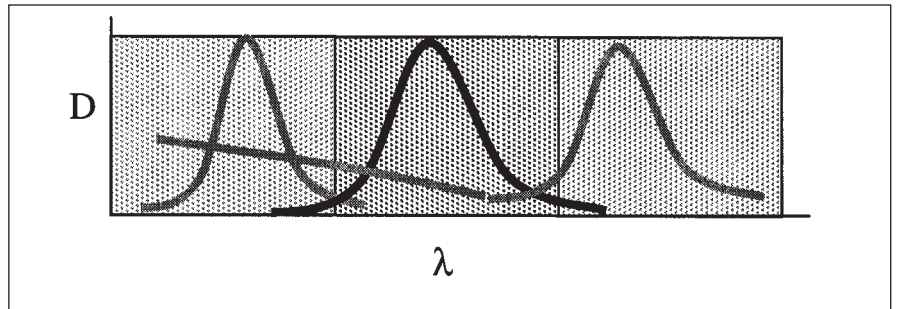

Figure 5. Typical spectrophotometry of real photographic dyes vs. block dyes.

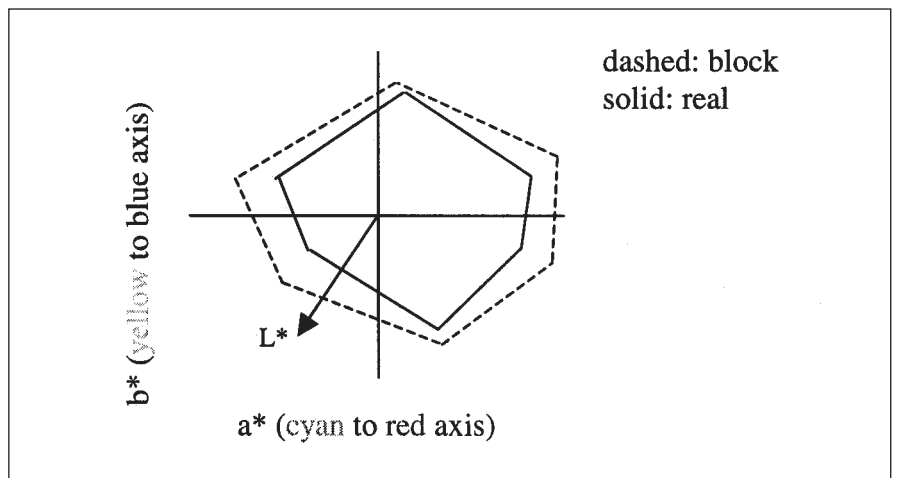

Figure 6. Example of the CIELAB hue gamuts of real and block dyes.

white). In between $L^*=0$ and $L^*=100$, however, the C^* plots form triangles as the hue colorfulness reaches some maximum at an intermediate lightness value. As stated earlier, the spectral dye density curve shapes of real dyes will change as a function of dye concentration. The nonlinearities in each of the triangular plots can be attributed to this change in "color" as a function of dye amount.

A final point needs to be made on image dye contributions to color reproduction. The subtractive photographic system has been described as one where cyan dye is intended to modulate only red light, magenta dye

only green light, and yellow dye only blue light.⁴ Figure 4 shows a spectrum of ideal "block" dyes. Figure 5 represents the spectrophotometry of a real dye set complete with the characteristic overlapping absorption patterns versus the block dye set.

Figure 6 compares the CIELAB hue gamuts of block dyes and real dyes. Hunt has shown that a set of "block" dyes built with optimized spectral densities can produce cleaner eye responses than a set of real dyes with overlapping absorptions. Because real dyes tend to modulate light across broader spectral zones, they create color "cross-talk" through unwanted absorptions. As a result, colors rendered with real dyes appear less colorful than they might for block dyes and the gamut of reproducible chromas is reduced. Again, this conclusion is predicated on the block dyes being chosen as ideal with respect to interactions with the eye.

To this point, the discussion has centered on the eye's response to a

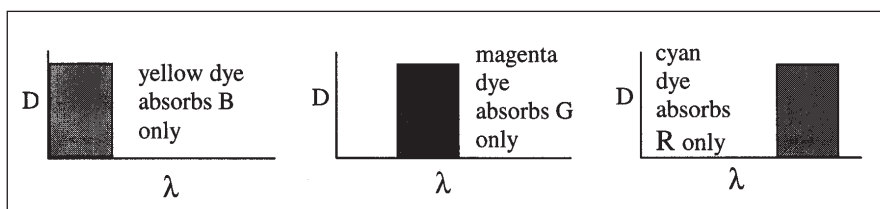

Figure 4. Sample spectra of three block photographic dyes.

color stimulus and the color space calculations used to characterize that response. As such, the most accurate color gamut calculations are intended for systems that are directly viewed by the eye (the capture film in a positive system or the receiving print film in a two-stage negative system). For a negative capture system, how the receiving film "sees" the dyes in the capture film must be described specifically. In fact, the color gamut that can be achieved with a piece of receiving color print film is not an entirely comprehensive measure of the colors that can be reproduced with that of print film. Rather, the color gamut of a two-stage negative system depends on both the dyes of the receiving film and the dyes of the capture film; consequently, the classic calculated receiving film gamut must usually be adjusted, in practical cases, to account for these influences.

The principal conclusion to draw from this analysis is that dye spectrophotometry is one of the key determinants of the color gamut that can be achieved with a typical photographic film.¹ Though the interactions of dye and eye are complicated in theory, comprehensive color space calculations developed to date have allowed systems to be modeled and understood in terms of true perceived color rendition.

The Impact of Exposure

As mentioned previously, the palette of colors that can be reproduced by a photographic product is a function of both the image dyes incorporated into the film and the photophysical features of the exposing process within the film. It is certainly important to discuss color gamut maps for film dye sets; however, the process by which light is converted into those dyes must be acknowledged. It is quite conceivable that a comparison of two films will find one to have a truly superior dye set represented in a much broader color gamut map than the other. It is also conceivable that the same film may not be able to image those superior dyes in a pure form and can therefore not fully utilize the advantaged spectral dye densities. In this case, the color space truly repro-

ducible within the film may actually be smaller (as a consequence of color contamination) than the second film with the inferior dye set.⁵

Three photographic design features describe the influence of the exposure stage of the image chain on color reproduction: spectral sensitivity, sensitometry, and image-modifying chemistry.² Spectral sensitivity dictates the amount of exposure to be recorded by each of the three layers in a film as a function of the incident wavelength of light.

Ideally, the red-sensitive layer has its peak sensitivity in the red portion of the spectrum; likewise the green-sensitive layer is most sensitive to green light and the blue-sensitive layer is most sensitive to blue light. Though this peak requirement may be well represented in real photographic films, there is still some degree of overlapping sensitivity among layers at the spectral boundaries as illustrated in Fig. 7.

The consequence of this overlap is illustrated with an example: any green light intended to expose only the green layer of the film may, as a function of specific spectral sensitivities, actually expose the red and the blue layers also, producing unwanted cyan and yellow dyes (a process known as punch-through). For "pure" spectral colors imaged by a film, rendering multiple dyes will usually reduce the chroma or colorfulness compared to a single dye (imagine a yellow color represented by yellow and magenta dyes rather than by yellow dye only). This should make further sense as it, in fact, takes approximately equal amounts of all three dyes in order to produce a true neutral (defined as zero chroma).

Color contamination is a result of the addition of the punch-through

dyes to the intended image dyes.⁶ Not only are real image dyes not perfectly cutting with respect to the eyes, as explained earlier, but real photographic products will not image the single dyes anyway. In a positive system, this comes into play as unwanted image dyes can be produced as a consequence of scene exposure. In a negative system, the phenomenon here is actually seen twice: first, when exposure to the capture film causes unwanted dye formation (due to the capture film spectral sensitivity); and second, when exposure through the capture image dyes causes unwanted exposure in the receiving film (because of the relationship between the receiving film spectral sensitivity and the capture film spectral dye densities).

The second exposure feature influencing color rendition is sensitometry (the amount of dye produced as a function of incident exposure). As spectral sensitivity dictates the punch-through exposure in a film, sensitometry will dictate how much unwanted dye that exposure will generate.²

Image-modifying chemistry is the last piece in the color reproduction puzzle. This feature, also designated interlayer interimage effects (IIE), represents the sum of attempts made by film designers to account for various unwanted spectral absorptions of image dyes and unwanted punch-through exposures recorded by multi-layer films. If spectral sensitivities and dye inefficiencies contaminate color reproduction, shrinking the reproducible color palette, IIE is the mechanism available for attacking the unwanted dyes and removing the unwanted absorptions.

Figure 8 shows one use of IIE in a

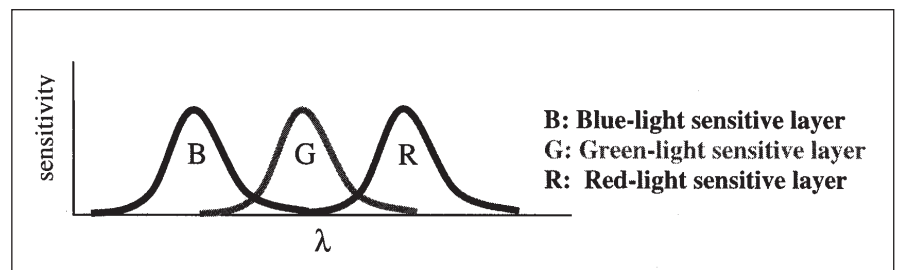

Figure 7. Typical spectral sensitivities of a photographic film.¹

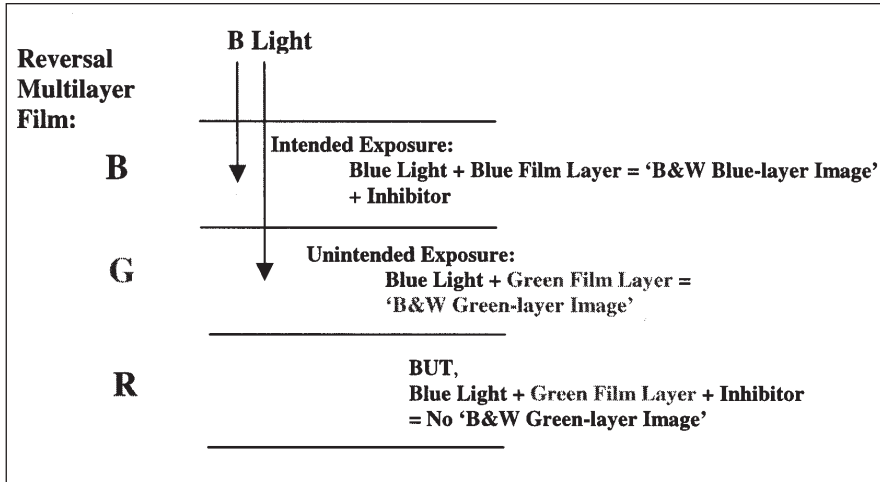

Figure 8. Example of IIE in a multilayer film.

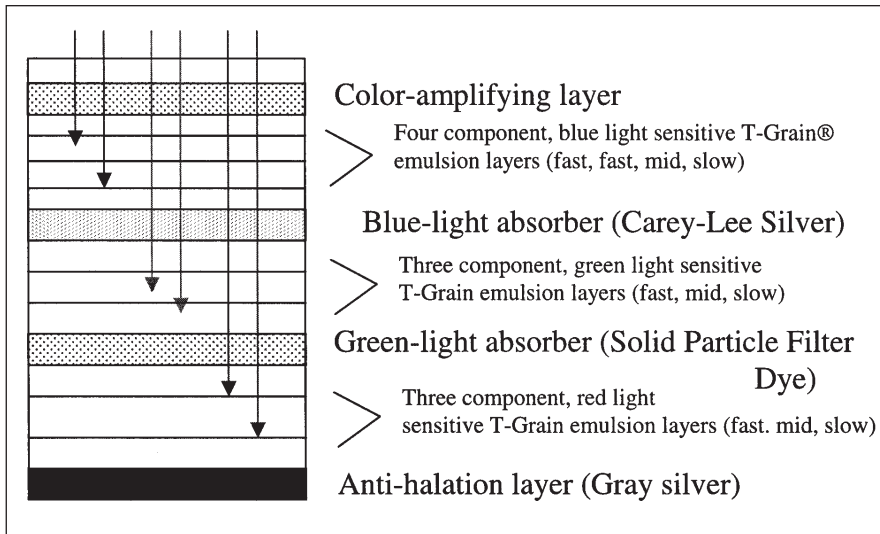

Figure 9. Layer structure of Ektachrome 100D film.⁷

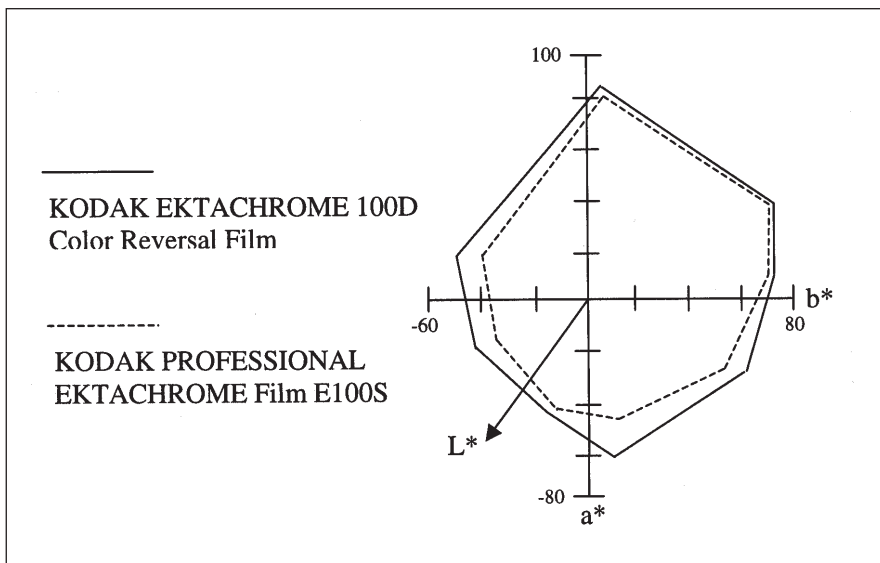

Figure 10. CIELAB color (hue) palette comparison of 100D and E100S film.

reversal film. In this example, blue light has exposed the blue layer of a film as intended but has also exposed the green layer of a film, producing unwanted "black-and-white green-layer image" via punch-through. (It is especially important to clarify that this is a reversal film system: where "black-and-white image" is recorded, there is no dye formed; and where "black-and-white image" is not recorded, dye is formed.)

To combat the punch-through problem, chemistry has been added to the blue layer such that when "black-and-white blue-layer image" is formed, an inhibitor molecule is released. That molecule can travel into the green layer and actually stop the reaction producing "black-and-white green-layer image" thereby preventing unwanted dye formation.²

This type of image modification approach can re-enlarge the color palette of a film, however, the techniques employed cannot solve all contamination problems. In a similar mechanism in negative capture films, IIE can be used to control unwanted negative dye formation (IIE is usually not used as extensively in the second-stage receiving films).

The Color Technology of 100D Film

The basic concepts associated with photographic color reproduction have been explained, and the technologies actually built into 100D color reversal film to effectively enlarge its color palette can be now addressed. Rather than concentrate on new image dye technologies, the scientists in the Kodak color reversal R&D labs determined there was more opportunity for enhancing color saturation in 100D film by manipulating exposure inefficiencies. New design techniques were incorporated to control the spectral sensitivity and interlayer interimage effects within the film.

In Fig. 9, the primary color control technologies are illustrated. The first layers to note are the Carey-Lee Silver blue-light absorber and solid particle filter dye green absorber placed above the green and red-sensitive emulsion layers, respectively. By

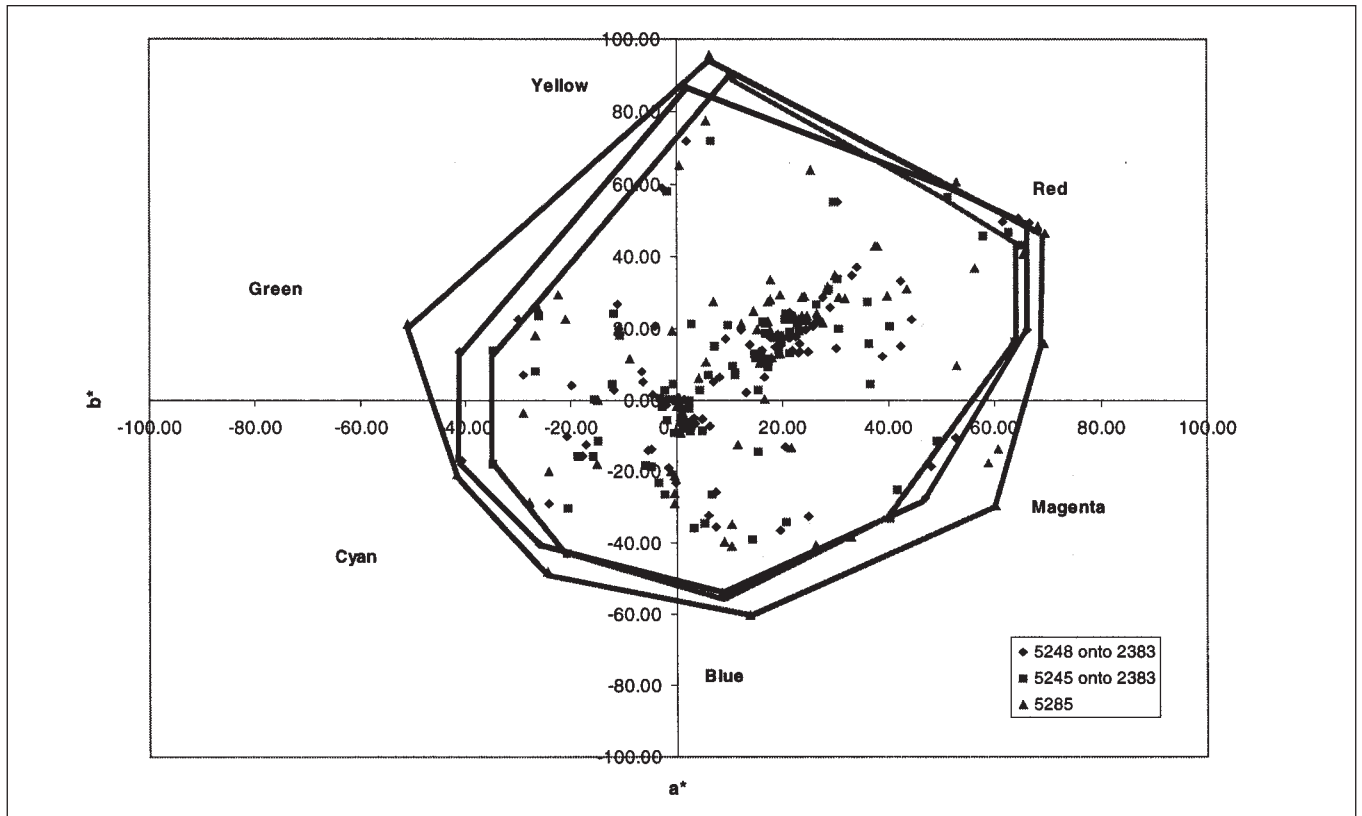

Figure 11. CIELAB color (hue) palette of 100D/5285 vs. EXR 100T/5248 and EXR 50D/5245, each printed onto Kodak Vision color print film/2383.

carefully controlling the properties of these two layers, the color reversal design team was able to sufficiently eliminate unwanted absorption of blue light by the green and red layers and unwanted absorption of green light by the red layer, effectively narrowing the spectral sensitivity bands for the respective layers (as compared to negative films) and cleaning up punch-through concerns.

The real improvement in color palette realized in 100D film, however, comes from the addition of a new layer to the top of the film structure. This color-amplifying layer improves color saturation by means of interlayer interimage effects and is the novel technology employed in the film. This layer is comprised of a slow, spectrally sensitized emulsion together with a very fine coating of silver halide. Upon exposure and black-and-white chemical development, this layer undergoes solution physical development, a process by which the silver ions within the fine emulsion are transported to the larger developing slow emulsion. As silver

ions are lost from the fine silver halide particles, halide is released into the film to act as an inhibitor in other layers.

The use of halide as an agent of IIE is classic; however, the mechanism introducing inhibitor from the new film layer is patented technology.⁷ By modulating dye formation in adjacent layers of the film, the new color-amplifying layer affects the amount of unwanted light absorption present in specific rendered colors. The added bonus is that sharpness is also greatly enhanced by the IIE reaction (just as it would be in any film incorporating this inhibitor-type chemistry).

A plot of 100D film's color (hue) palette is compared to the preceding Kodak reversal color technology (Fig. 10). Practical picture testing against properly exposed and printed motion picture negatives also shows a color palette advantage for the 100D film, though this must be qualified against the fact that a good color timer can often oversaturate specific colors in a scene when willing to sac-

rifice overall color and tone reproduction accuracy. This said, the total range of color saturation available with 100D film across the entire visible spectrum has been found to be larger than that for the classic motion picture negative system (Fig. 11).

All of the color enhancements in 100D film are balanced carefully against proper neutral and flesh tone reproductions. A specific benefit is the ability to offer a high level of color saturation at a true EI100 speed while concurrently reproducing flesh and neutral tones quite accurately. All of these features combine to provide the cinematographer with an excellent tool for capturing and reproducing a new look in the motion picture market.

Market Applications

The introduction of Ektachrome 100D film has prompted a number of questions about its motion picture applications. As a positive original film, it is most easily used for telecine transfer of commercials and television shows. Because the color

enhancement technology in the film is centered on controlling unwanted dye formation, it will produce colors that are more saturated not only to the eye, but also relative to a telecine's input spectral sensitivity. Of course, within the telecine environment, color manipulation is a key factor. Still, it would require some time to take another film and produce the colors that can be seen with 100D film right out of the camera (as well as some likely increase in noise).

A positive 100D film image can also be incorporated into feature productions via the use of a digital intermediate path wherein the images are scanned, interpolated, and recorded as a negative set of densities on color intermediate film. In this case, the integrity of the original captured positive can be maintained through the systems and then output to a distribution film.

Finally, the most exciting aspect about reversal motion picture films is cross-processing. A set of unique looks can be achieved by sending images on 100D film through an ECN-2 negative process. The impact on both tone scale and color reproduction place tremendous control in the hands of the cinematographer to achieve a look not available by other means.

Conclusion

Controlling unwanted dye formation through chemical interlayer interimage effects enables Kodak Ektachrome 100D film to reproduce the widest color palette of any 100 speed reversal film, exceeding the practical limits of the motion picture negative system. Thus, 100D film offers cinematographers a new tool for manipulating color, style, and look in their finished products.

Endnotes

1. R.W.G. Hunt, *The Reproduction of Colour, 5th ed.*, Fountain Press, England, 1995.

2. T. H. James, Ed., *The Theory of the Photographic Process, 4th ed.*, MacMillan, New York, 1977.

3. Several techniques have been developed over the years to define human perceptible color space in terms of meaningful metrics. As this paper is not intended to be a tutorial on those measures and techniques, the reader is encouraged to check the Hunt¹ references for more details in this area. With respect to our discussion here, the color metric of choice will be the CIELAB color space (Commission International de l'Eclairage LAB).

4. As it turns out, the eye's spectral response to light is not as clear-cut as has been insinuated thus far. The three color-sensing cones, which enable us to perceive visible colors, do not absolutely differentiate red, green, and blue light, but are rather characterized by some degree of overlapping sensitivity (especially the red and green cones). Consequently, the eye's definition of red, green, and blue light is somewhat convoluted in spectral space. Rather than spend too much effort clarifying this point, it is sufficient to summarize that the interaction of spectral dye densities and the spectral responses of the three cones of the eye will dictate the dye system's color gamut.

5. The concept of color palette is a much better tool than color gamut for comparing positive and negative systems. In the positive system, the image dyes incorporated can be converted into a classic CIELAB color gamut (independent of exposure effects), but negative film dyes can only be defined in an "effective gamut" dependent on the spectral sensitivity of the receiving film. As it contains a dye set meant to be directly viewed, the receiving film is eligible for classic CIELAB representation, but this would ignore the influence of the negative dye properties on the actual amount of receiving film dyes that can be produced in printing stages. In essence, the two-stage negative system is the perfect example of how exposure conditions can and will cause color gamuts and color palettes to differ in

realistic photographic applications.

6. Some spectral sensitivity overlap is not always detrimental. It is, in fact, quite necessary for correctly reproducing some difficult color transitions (teals, oranges, etc.) and is used in conjunction with other chemical manipulations to enhance hue accuracy in films.¹ Still, when not properly checked, the consequence of this type of spectral punch-through will be a loss of apparent saturation in reproduced images.

7. Keath Chen, "Reversal Photographic Elements Comprising an Additional Layer Containing an Imaging Emulsion and a Non-Imaging Emulsion," U.S. Patent #5,932,401, 1999.

THE AUTHOR



David Long joined Kodak in 1997 as a member of the Manufacturing Research and Engineering Organization. In 1998, he moved into his current role as product development engineer with the Professional Motion Imaging Division. His primary responsibilities include new product development and image science and systems integration for the motion picture product platform.

Long came to Kodak from the University of Texas at Austin where he earned his B.S. in chemical engineering; he is also a graduate of Kodak's Image Science Career Development Program.
