

# New Members

The following members have been added to the Society's rolls since the September 1976 *Journal*. Also listed are those regretfully reported as deceased since then. The designations of grade are the same as those used in the Directory. An up-to-date list of the Sustaining Members appears on the outside cover of each month's *Journal*. The members listed below complete the Society's roll as of December 10.

The *Directory For Members* shows the geographic membership distribution within each Section.

Honorary (H)	Life Fellow (LF)	Life Member (LM)	Fellow (F)
Active (M)	Associate (A)	Student (S)	

## Deceased:

Byron L. Allison (M)	Samuel H. Barbour (M)	J. Richard Butler (M)
Helge Olof Bylund (A)	Leo Chase (LM)	Nick Culic (A)
Robert B. DiMurro (A)	William J. Folsom (A)	Eric A. Herren (A)
Hal Hornstein (M)	Bernard R. Kantor (F)	Dan D. Monaco (M)
N. K. Peach (A)	Edward R. Schinke (M)	Nirmal C. Sen Gupta (A)
Raymond J. Sharples (M)	Glenn R. Simmons (A)	Howard W. Town (F)
Milton W. Willenson (M)	William Wintringham (F)	

## ATLANTA SECTION

**Abercrombie, Joe M.**, Engrg. Supvr., WSB-TV. Mail: 4424 Lake Ivanhoe Dr., Tucker, GA 30084 (M)

**Byars, Jay W.**, Electronics Engr., Ampex Corp. Mail: 2161 Pinehurst Rd., Snellville, GA 30278 (A)

**Clarine, Jeffrey N.**, Regional Mgr., Philips Audio Video Systems Corp. Mail: 867 Rockbridge Rd., Norcross, GA 30071 (A)

**Couch, James F.**, Mot. Pic. Prodn. Supvr., Ga. Dept. of Natural Resources. Mail: 1075 N. Hairston Rd., 29H, Stone Mountain, GA 30083 (M)

**Freeman, J. Michael**, TV Applications Consult., Applied Video Concepts, Ltd. Mail: 6643 E. Lake Hill Dr., Raleigh, NC 27609 (A)

**George, Eugene W.**, Res. Physicist, Teledyne Brown Engineering. Mail: 2608 Gamma Circle, Huntsville, AL 35810 (M)

**Gordon, William D.**, Chf. Photographer, WFMY-TV. Mail: Rt. 9, Box 514, Greensboro, NC 27409 (M)

**Grateau, Jr., Kent H.**, Chf. Engr., Mobile Image Atlanta, Inc. Mail: 1834 Cashmere Ct., Lithonia, GA 30058 (A)

**Harrington, Ronald P.**, Asst. News Mgr., Jefferson Pilot Broadcasting Co., 1 Julian Price Pl., Charlotte, NC 28208 (M)

**Holes, Cheyney M.**, Filmmaker, Cedarside Productions. Mail: Rt. #1, Box 78-A, Hurdle Mills, NC 27541 (M)

**Hughes, Larry A.**, Systems Engr., Signal Engineering & Sales Inc. Mail: 2575 J Mountain Lodge Circle, Birmingham, AL 35216 (M)

**Jones, Steven M.**, Video Operations Mgr., Holiday Inn Univ., 1150 E. Goodman Rd., Olive Branch, MS 38654 (M)

**Kruger, Helen N.**, Sales Engr., Amperex Electronic Corp., P.O. Box 98156, Atlanta, GA 30359 (M)

**Marshall, Rebecca N.**, Scriptwriter, Ga. Dept. of Natural Resources. Mail: 980 Briarcliff Rd., N.E., Atlanta, GA 30306 (A)

**Morris, Walter H.**, Sr. Techn., WAGA-TV. Mail: 2242 Greenway Dr., Decatur, GA 30032 (M)

**Nobles, Dan**, Sr. Techn., WAGA-TV. Mail: 559 Hammett Dr., Decatur, GA 30032 (M)

**Swinyer, Arch**, Video Systems Consult., Gray Communications Consultants. Mail: 2971 Womack Court, Atlanta, GA 30340 (A)

## AUSTRALIA SECTION

**Bowden, Barry V.**, Supvr., Sound, Australian Film Commission. Mail: 14 Correys Ave., Concord, N.S.W., Australia 2137 (M)

**Brown, Barry C.**, Managing Dir., Sound On Film Pty Ltd. Mail: 63 Mimosa Rd., Turrumurra N.S.W., Australia 2074 (M)

**Carter, John**, Prodn. Mgr., Film Australia. Mail: 65 Duffy Ave., Thornleigh, N.S.W., Australia 2130 (M)

**Daggett, Donald G.**, Dir. Sound on Film Pty Ltd., 50 Atchison St., St. Leonards, Sydney, N.S.W., Australia 2065 (M)

## CHICAGO SECTION

**Auerbach, David F.**, Southern Illinois Univ. Mail: 753 LaCross, Wilmette, IL 60091 (S)

**Badiyan, Fred**, Sight & Sound Productions, Inc.,

6315 Penn Ave. So., Minneapolis, MN 55423 (A)

**Basley, Bernard E.**, Columbia College. Mail: 1957 N. Dayton, Chicago, IL 60614 (S)

**Beierle, Richard D.**, Bismarck Jr. College. Mail: 815 N. 17 St., Bismarck, ND 58501 (S)

**Breen, Myles P.**, TV Studio Coordinator, Northern Illinois Univ. Mail: 1908 Margaret La., DeKalb, IL 60115 (M)

**Buchanan, Evelyn A.**, Columbia College. Mail: 5337 S. Hyde Pk., Bldg. 401, Chicago, IL 60615 (S)

**Camerini, Michael**, Univ. of Wisconsin. Mail: 3925 Plymouth Circle, Madison, WI 53705 (S)

**Campbell, Joseph H.**, Univ. of Iowa. Mail: 528 N. Gilbert, Iowa City, IA 52240 (S)

**Cicora, Dr. Walter S.**, Section Mgr., Research, Zenith Radio Corp. Mail: 403 S. Knight, Park Ridge, IL 60068 (M)

**Craig, Kathleen M.**, College of DuPage. Mail: 5540 Walnut, Apt. 31C, Downers Grove, IL 60515 (S)

**Deutsch, William F.**, Engr., Arthur Anderson & Co. Mail: 636 Devonshire La., Crystal Lake, IL 60014 (A)

**Erikson, Gregory A.**, Southern Illinois Univ. Mail: 4737 S. Harding, Chicago, IL 60632 (S)

**Erickson, Rae A.**, Project Engr., Wilding Co., 500 N. Michigan Ave., Suite 1900, Chicago, IL 60611 (A)

**Feaster, Jack A.**, Chf. Video Engr., Computer Creations Corp. Mail: 1970 Brookmeade Dr., South Bend, IN 46614 (A)

**Ferraro, Michael P.**, Dir. of Photographic Services, Pettibone Corp. Mail: 5838 N. Sacramento, Chicago, IL 60659 (A)

**Flannery, Kenneth F.**, AV Equipment Coordinator, Iowa State Univ. Mail: 128 N. Hyland #1, Ames, IA 50010 (A)

**Futrelle, Robert P.**, Asst. Professor, Univ. of Illinois, Genetics & Dev., 515 Morrill Hall, Urbana, IL 61801 (M)

**Germain, David L.**, Dir., German Prof. Communication Serv., 3964 Shaw Blvd., St. Louis, MO 63310 (A)

**Glazier, Gregory K.**, Sound Engr., Maritz Laboratories Inc. Mail: 3031 Ewing Ave., S. Apt. 138, Minneapolis, MN 55416 (A)

**Gleissner, Bernard F.**, Engrg. Supvr., KCMO-TV. Mail: 5620 Beverly La., Mission, KS 66202 (M)

**Hecker, Thomas W.**, Chf. Engr., Arthur Andersen & Co. Mail: 1811 Lancashire Ct., Schaumburg, IL 60194 (M)

**Hess, Robert B.**, Purchasing Agent/Prodn. Asst., United Learning Corp. Mail: 2315 E. Olive St., Apt. 2-J, Arlington Heights, IL 60004 (M)

**Hirsch, Robert O.**, Vice Pres., Hirsch Broadcasting Co., 324 Broadway, Cape Girardeau, MO 63701 (M)

**Hopkins, James P.**, Plastic Surgeon, 6700 Troost, Suite 212, Kansas City, MO 64131 (M)

**Hoyt, Howard R.**, Asst. Chf. Engr., Chicago City Colleges. Mail: 401 W. Webster, Chicago, IL 60614 (M)

**Jones, Ernest T.**, Owner-Mgr., Corn Husker Film Proc. Lab., 1817 Vinton St., Omaha, NB 68108 (M)

**Kirby, Don D.**, St. Video Engr., 3M Co. Mail: 809 W. Cope, St. Paul, MN 55113 (A)

**Klimek, Thomas F.**, Pres., Computer Creations Corp. Mail: 1609 E. Cedar St., South Bend, IN 46617 (A)

**Larkin, Richard D.**, Prodn. Asst., Sedelmaier Film Productions Inc. Mail: 4426 Washington St., Downers Grove, IL 60515 (A)

**Lindwall, Martin A.**, 2147 Ridge Ave., Evanston, IL 60201 (A)

**Lobacz, Nicholas**, Machine Maint. Techn., Douglas Film Inds. Mail: 1521 N. Lorel St., Chicago, IL 60651 (A)

**Paddock, Jr., Charles E.**, Chairman, Paddock Film Productions, 9101 Barton, Overland Park, KS 66214 (M)

**Payne, William F.**, Stephens College. Mail: 301 N. Williams St., Columbia, MO 65201 (S)

**Penkalski, Ervin**, 3788 N. Humboldt, Milwaukee, WI 53212 (A)

**Randell, Ronald**, Mot. Pix Tec. Sales Rep., Agfa-Gevaert, Inc. Mail: 918 Washington St., Evanston, IL 60202 (M)

# THE END OF HALF OF YOUR CAMERA PROBLEMS

No two motion picture assignments are exactly alike. So it follows that no one camera or lens is right for every assignment. Which in part explains the enormous proliferation of cameras and lenses that has taken place over the last several years. Well, whatever the format,

whatever the camera, whatever the lens, whatever the accessory, you can be sure of one thing—Camera Mart's got it. In stock and in depth. And whether you buy it from us or rent it from us, chances are it'll cost you a lot less than you thought.



# THE END OF THE OTHER HALF.

But getting the right gear is only half the answer. The other half is *where* you get it. In effect, the *people* you get it from. Does the place maintain a full staff of factory-trained technicians? Are they fanatic about checking and re-checking every piece of gear—however small—before it leaves the premises? Are they familiar enough with motion picture problems to suggest another, even more suitable piece of equipment than

you originally specified? And, if by some remote possibility the equipment should fail, do they stand ready to rush out, day or night, rain or shine, with a replacement? If you're dealing with Camera Mart, the answer to all the above is an emphatic yes. But why take our word for it? Everybody's making claims these days. Check for yourself. Just ask someone—anyone—who's ever dealt with us.

CAMERA MART 456 West 55 Street New York, N.Y. 10019

You make sense. Tell me more about how Camera Mart can solve both halves of my camera problems.

NAME \_\_\_\_\_ TITLE \_\_\_\_\_

COMPANY \_\_\_\_\_

ADDRESS \_\_\_\_\_

CITY \_\_\_\_\_

STATE \_\_\_\_\_ ZIP \_\_\_\_\_

© 1974, Camera Mart



**CAMERA MART**  
THE CAMERA MART INC

456 W. 55th St., New York, 10019 (212) 757-6977  
SALES-SERVICE-RENTAL

**Ranogajec, Zvonko B.**, Independent Filmmaker, Branko Rano, Inc., 4745 N. Beacon St., Chicago, IL 60640 (A)

**Rene, Robert L.**, News Photographer, WAFB-TV, Mail: P.O. Box 1801, Baton Rouge, LA 70821 (M)

**Reynolds, Vernon O.**, Producer, R. R. 2, Jubilee Hills Dr., Brimfield, IL 61517 (A)

**Ruh, Henry B.**, Asst. Chf. Engr., WFUI-WTIV, Indiana Univ., Radio-TV Bldg., Bloomington, IN 47401 (M)

**Shiver, J. Arthur**, Chf. News Photographer, KSLA-TV, Mail: P.O. Box 4103, Shreveport, LA 71104 (M)

**Speck, William N.**, Engrg. Supvr., 3M Co. Mail: 467 Wagner St., Roseville, MN 55113 (M)

**Stoll, Michael H.**, Industrial Sales Mgr., Crown International, Inc. Mail: 1821 Grant St., Elkhart, IN 46514 (M)

**Zwiec, Joe**, Distribution Supvr., Learning Corp. of America, 4600 W. Diversey, Chicago, IL 60639 (A)

**Thomas, Jr., Charles J.**, Mktg. Mgr., Bell & Howell Co. Mail: 410 Wilmot Rd., Deerfield, IL 60015 (M)

**Ure, David**, Projectionist, Catholic Television Network, Mail: 1525 W. Birchwood, Chicago, IL 60626 (M)

**Zastrow, Eugene S.**, Asst. Technical Dir., Univ. of Wisc. Mail: 1713 Hickory Dr., Madison, WI 53705 (M)

### DALLAS-FT. WORTH SECTION

**Ashby, Linda J.**, NTSU-Denton, Mail: 1004 W. Mulberry, Apt. C, Denton, TX 76201 (S)

**Apsey, Mike**, Mot. Pic. Soundman, Rt. 6—Box 573, McKinney, TX 75069 (M)

**Cook, James E.**, Audio Visual Dir., A.C.E. Schools, Inc. Mail: 3206 Sheridan, Garland, TX 75041 (M)

**Falkiewicz, Richard D.**, Eastfield College, Mail: 9825 Starlight, Apt. 267, Dallas, TX 75220 (S)

**Groebe, James L.**, Trinity Univ. Mail: 11122 W. Ricks Circle, Dallas, TX 75230 (S)

**Parker, Daryl E.**, Broadcast Products Mgr., Martin, Zienkosky, Browne & Assoc. Mail: 7028 Pinon, Ft. Worth, TX 76116 (M)

**Pate, Sam**, Vice Pres., Mktg., Delcom Corp. Mail: 4527 E. 49 St., Tulsa, OK 74135 (M)

**Pfeiffer, Philip**, Cameraman—Gaffer, 5631 Mata-lice, Dallas, TX 75206 (M)

**Pouliades, Peter C.**, North Texas State Univ. Mail: P.O. Box 9572, NT Station, Dallas, TX 76203 (S)

**Powell, John A.**, Forte Recording Equipment Co. Mail: 2500 Glacier, Irving, TX 75062 (M)

**Roberts, Tom**, Sales Engr., Delcom Corp. Mail: 7439 S. Yale #144, Tulsa, OK 74136 (M)

**Todd, Colleen A.**, Scriptwriter, Tulsa Films. Mail: 8128 E. 16 St., Apt. 119, Tulsa, OK 74112 (A)

**Wood, Bob**, Assoc. Audio Visual Dir., A.C.E. Schools, Inc. Mail: 1533 Town Bluff, Garland, TX 75040 (M)

### DETROIT SECTION

**Bryan, Bill**, Equipment Maintenance Prodn. Mixer, Special Recording Inc. Mail: 5297 Newport, Detroit, MI 48213 (A)

**Klueck, Gary G.**, TV Operations Engr., WXYZ-TV, Mail: 14440 Hazelridge, Detroit, MI 48205 (A)

**Lord, Michael A.**, Grand Valley State College, Mail: 3030 Lake Michigan Dr., NW, Grand Rapids, MI 49504 (S)

**Raznik, Joseph D.**, Broadcast Engr., University of Michigan, Mail: 2108 Glencoe Hills Dr., Apt. 11, Ann Arbor, MI 48104 (A)

**Troll, Leonard E.**, Engr., WGVC-TV, Mail: 18501 R Drive N., Marshall, MI 49068 (A)

**Waskul, Pamela D.**, Tape Inspection, NET Television Inc. Mail: 210 N. Washington #10 Ypsilanti, MI 48197 (A)

**Williams, Huey J.**, Oakland Community College, Mail: 29 Salmer Apt. 8, Pontiac, MI 48053 (S)

### FLORIDA-CARIBBEAN SECTION

**Appleson, Patrick G.**, Pres., Pat Appleson Studios Inc., 171 N.E. 166 St., N. Miami Beach, FL 33162 (M)

**Cripe, Jesse H.**, Dir. of Broadcast Services, Univ. of FL, Mail: 2701 NW 23 Blvd., Apt. B-18, Gainesville, FL 32605 (M)

**Dubs, Philip M.**, Regional Mgr., Microtime, Inc., 9771 NW 24 Ct., Sunrise, FL 33313 (M)

**Huff, Theodore A.**, System Engr., Perry Cable Television Co. Mail: 1829 N.W. Pine Tree Way, Stuart, FL 33494 (M)

**Kelly, James M.**, Lab. Mgr., Russell Film Labs, Mail: 6859 Bakersfield Dr., Jacksonville, FL 32210 (A)

### HOLLYWOOD SECTION

**Alexander, Alnz**, Columbia College, Mail: 6071 Hargis St., Los Angeles, CA 90034 (S)

**Alexander, Joseph**, Technical Dir., Hollywood Film Co., 956 Seward St., Hollywood, CA 90038 (M)

**Babalola, Collins O.**, Columbia College, Mail: P.O. Box 48292, Los Angeles, CA 90048 (S)

**Barton, Larry E.**, Electronic Engr., Tyler Camera Systems, Mail: 16059 Temecula St., Pacific Palisades, CA 90272 (A)

**Blaney, Robert A.**, Los Angeles City College, Mail: 5205 Beckford Ave., Tarzana, CA 91356 (S)

**Boegner, Ray F.**, Lamp Engr., Optical Radiation Corp., 6352 N. Irwindale Ave., Azusa, CA 91702 (M)

**Burton, Robert R.**, Columbia College, Mail: 6871 Pacific View Dr., Hollywood, CA 90068 (S)

**Cameron, Bill**, Engr., KHJ-TV, Mail: 1914 Lasita Place, San Pedro, CA 90732 (A)

**Clark, Dave S.**, Baylor Univ. Mail: 1010 W. Gold Ave., Hobbs, NM 88240 (S)

**Clement, Rico**, Columbia College, Mail: P.O. Box 3902, Hollywood, CA 90028 (S)

**Coe, Peter T.**, Pres., Berkey Colortran, Inc., 1015 Chestnut St., Burbank, CA 91502 (M)

**Cole, Larry S.**, Century City Photography, 1834 Overland Ave., Los Angeles, CA 90025 (M)

**Davis, Richard M., MD**, 2222 Santa Monica Blvd., Santa Monica, CA 90404 (M)

**DeMattos, Carlos D.**, Vice Pres., Treasurer, Matthews Studio Equipment Inc. Mail: 4226 Escondido Dr., Malibu, CA 90265 (A)

**Deppe, Harold W.**, Maintenance Supvr., Univ. of Arizona, Mail: 7501 E. Lester Circle, Tucson, AZ 85715 (A)

**Dickson, Thomas S.**, Studio Projectionist, Major Motion Picture Studios, Mail: 3517 Warner Blvd. #12A, Burbank, CA 91505 (A)

**Dietenhofer, James C.**, Western States Refining Corp., 18555 E. Valley Blvd., Industry, CA 91744 (A)

**Dorfman, Sheldon R.**, Columbia College, Mail: 2742 Maxson Rd., El Monte, CA 91732 (S)

**Fluster, Barry K.**, Gen. Mgr., Media Fabricators, 5071 W. Washington Blvd. Los Angeles, CA 90016 (M)

**Fodor, Imre**, Design Engr., Ryder Magnetic Sales Corp. Mail: 11442 Dellmont Dr., Tujunga, CA 91042 (M)

**Galbreath, Kirk**, Pasadena City College, Mail: 147 N. Michigan Ave., #1, Pasadena, CA 91101 (S)

**Hetland, Harvey D. D.**, TV Engrg. Instructor, Pasadena Area Community College, Communications Dept., 1570 E. Colorado Blvd., Pasadena, CA 91106 (A)

**Hicks, P. Richard**, Telecommunication, 465 W. Washington, Pasadena, CA 91103 (A)

**Hall, Clifford D.**, U.S.C. Mail: 11570 Hartsook St., North Hollywood, CA 91601 (S)

**Hanrahan, Bruce**, Asst. Film Editor, Universal City Studios, Mail: 11926 Hartsook St., North Hollywood, CA 91607 (A)

**Hardt, Gary R.**, Pres., Magnetic Products Corp., 15444 Cabrillo Rd., Van Nuys, CA 91406 (M)

**Huffaker, Allan**, Pasadena City College, Mail: 125 Fano St., Arcadia, CA 91006 (S)

**Hughes, Rosalie L.**, CA State Univ. Mail: 1215 Dunning Dr., Laguna Beach, CA 92651 (S)

**Irwin, Steve**, West Coast Field Service Engr., Datatron, Inc. Mail: 1865 Port Margate, Newport Beach, CA 92660 (A)

**Joffe, Moe**, 7259 Willoughby Ave., Los Angeles, CA 90046 (M)

**Johnson, Gary R.**, TV Techn., Arcadia Unified School District, Mail: 835 Fairview Ave., Apt. 5, Arcadia, CA 91006 (A)

**Klages, Kevin W.**, Film Techn., Film Service Laboratories, Inc. Mail: 11220 Haskell Ave., Granada Hills, CA 91344 (A)

**Krieg, Paul**, Columbia College, Mail: 4835 Mary Ellen Ave., Sherman Oaks, CA 91423 (S)

**Lamphear, Marc**, Pasadena City College, Mail: 346 Markham Pl., Pasadena, CA 91105 (S)

**Leaman, E. J.**, Producer-Director, MP & TV, Univ. of Calif. Mail: 223 W. Valerio St., Santa Barbara, CA 93101 (M)

**Mallory, Charles S.**, Plant Supt., Mitchell Camera Corp. Mail: 1301 Norton Ave., Glendale, CA 91202 (M)

**Martin, James R.**, Mot. Pic. Editor, U.S. Air Force, Mail: 1501 Gochwind S.W., Albuquerque, NM 87105 (A)

**Martinez, Victor**, Pasadena City College, Mail: 11063½ McGirk Ave., El Monte, CA 91731 (S)

**Masten, William N.**, Cameraman, Self Empl., 5545 Allott Ave., Van Nuys, CA 91401 (A)

**Norwood, Kim C.**, Pasadena City College, Mail: 2758 Keystone St., Burbank, CA 91504 (S)

**Pfeiffer, Scott**, Pasadena City College, Mail: 423 S. San Marino Ave., Pasadena, CA 91107 (S)

**Roberts, Marvin A.**, Sun Laboratory Systems, 7645 Densmore Ave., Van Nuys, CA 91406 (M)

**Robey, Donald W.**, Columbia College, Mail: 1227 N. Genesee #1, Hollywood, CA 90046 (S)

**Rogers, Donald C.**, Technical Dir., Samuel Goldwyn Studio, Sound Dept., 1041 N. Formosa Ave., Los Angeles, CA 90046 (M)

**Scott, Thomas E. III**, Broadcast Service Engr., Sony Corp. Mail: P.O. Box 326, Calimesa, CA 92320 (A)

**Sharifpour, Soleiman**, Columbia, Mail: 3554 Mentone Ave. #1, Los Angeles, CA 90034 (S)

**Sherman, Robert**, Assoc. Producer, Goodson-Todman Productions, Mail: 1555 Rising Glen Rd., Los Angeles, CA 90069 (A)

**Smith, David M.**, Calif. State Univ. Mail: 307 S. 3 St., Alhambra, CA 91801 (S)

**Starkweather, Melinda**, Pasadena City College, Mail: 580 Buena Loma, Altadena, CA 91001 (S)

**Teeman, Richard N.**, Photographer II, L. A. County Sheriff Dept., 501 N. Main St., Los Angeles, CA 90012 (M)

**Trotter, Michael D.**, Columbia College, Mail: 1555 N. Bronston, Apt. #101, Hollywood, CA 90028 (S)

**Turang, Paul J.**, Supvr. Chf. Engr., Hollywood Turf Club, Mail: 3014 McNab Ave., Long Beach, CA 90808 (A)

**Wada, Tomoo**, Mgr., Sony Corp. of America, 700 W. Artesia Blvd., Compton, CA 90220 (A)

**Ward, Steven A.**, Asst. Prodn. Mgr., Video Systems Network, Inc. Mail: 256 S. Robertson Blvd., Beverly Hills, CA 90211 (A)

**Weite, Chuck**, Television Workshop, Mail: 8045 Sepulveda Blvd. #24, Van Nuys, CA 91402 (A)

**Wells, William**, Chf. Design Engr., United Audio Visual Corp. Mail: 5228 Mountain View Dr., Las Vegas, NV 89102 (A)

**Woodka, Richard**, Technical Dir., Metromedia, Inc. Mail: 3939 Veselich Ave., #122, Los Angeles, CA 90039 (A)

**Zolle, Willi H.**, Pres., Specialized Industries, Inc. Mail: 595 Moreno Ave., Los Angeles, CA 90049 (M)

### HOUSTON SECTION

**Blachly, William E.**, Consulting in Sound Recording & Reproduction Sound by Blachly, 2307 Northland Dr., Austin, TX 78756 (A)

**Boyd, John L.**, Plant Mgr., Fox-Stanley Photo Products, Inc. Mail: P.O. Box 1105, Conroe, TX 77301 (M)

**Cook, Phillip G.**, District Mgr., Bell & Howell Co. Mail: 12030 Meadowdale, Stafford, TX 77477 (M)

**Dickensheets, Kenneth R.**, Assoc. Consl., Boner Assoc., Conslts. in Acoustics, 1508 Hardouin, Austin, TX 78703 (M)

**Griffin, Alfred C.**, Med. TV Coordinator, Gaylor College of Medicine, Mail: 2107 Sheridan, Houston, TX 77030 (M)

**We know there are  
other processing labs  
in the world  
as good as we are.**

**Surely.**

PROCESSING • SOUND • PRODUCTION SERVICES • PRINTING • SPECIAL SERVICES • RENTAL • SALES • REPAIRS

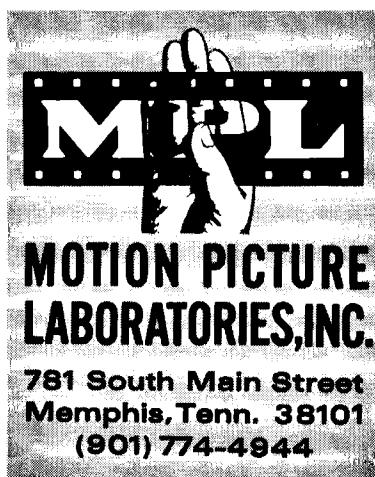

MOTION PICTURE LABORATORIES, INC., Piedmont Division, 2517 South Boulevard, Charlotte, North Carolina 28203, (704) 525-5416  
MOTION PICTURE LABORATORIES, INC., Suite 940, 1120 Connecticut Ave. N.W., Washington, D. C. 20036, (202) 659-3528  
CINE-CRAFT LABORATORIES, 8764 Beverly Boulevard, West Hollywood, California 90048, (213) 652-7357



# QUINN MARTIN



*How do you produce a TV show that gets a seventy-three share? What's the secret of producing one series after another, running season after season, while others have trouble surviving thirteen episodes?*

*For the answers to these and other questions, we've gone to the same source as the networks—to Quinn Martin.*

*Quinn, how did you get started in the film business?*

I started out as a film editor, became a writer, then a producer.

*What was your first major success?*

The first critical success I had was a film for television called "Bernadette," but the show that probably played the most important part in my career was "The Untouchables."

When I formed my own company in 1960, one of our first shows was "The Fugitive." It became the number one show, won an Emmy for "Best Dramatic Show," and was critically acclaimed. So I would say, for me, even though "The Untouchables" was the show that gave me a big start, "The Fugitive" is the one I'll always have in my heart because it cemented the company's name as a producer of quality products.

*I remember the original two-hour "Untouchables." Part Two, which played a week later, got one of the highest ratings ever, as did the last episode of "The Fugitive."*

*What changes have you noticed in production methods from those shows and the ones you have on the air now?*

If I made any mark in this business, it was to force television off the sound stages and back lots. People were horrified at my wanting to shoot on real locations. Now it's a common practice for us to shoot five out of seven days on locations. We average about forty setups a day.

This has been made possible by the improvements in camera equipment and film.

One of the reasons I accepted doing this interview is I have no problem doing it. I don't normally do these kinds of things, but I like Eastman Kodak Company. They're always there. You know you're dealing with a company that is constantly working, upgrading the product, researching new ones.

When their new, fine-grain Eastman color negative II film 5247 came out, "Streets of San Francisco" was one of the first series to use it. We thought it would be perfect for the dramatic documentary look we wanted. Frankly, I wasn't too happy with it then because we had problems with backgrounds changing colors. We called in a Kodak consultant, got together at the lab, and after doing a lot of tests, we ironed out the problems. Kodak kept improving it and now I think it's probably the finest stock I've ever seen.

*Have you ever used videotape?*

No, I've never worked with tape. It may become a reality some day for action adventure shows, but I feel the equipment has to improve some more. Also, I like the subtle way with which lighting can be handled on film. I still like to paint through my cinematographer.

*I notice your desk is covered with scripts. What are some basic things you look for?*

Scripts that deal with human emotions, that don't write down to people. I believe you have to give people credit for their level of understanding. If they don't understand it intellectually, they'll understand it emotionally. Whatever success we've had comes from the attitude that people deserve better.

One of our TV movies, "Attack On Terror," was about the three civil rights workers killed in the South in 1965.

It wasn't a popular subject, but we felt it should be done. As it turned out, it was one of the highest rated shows of the year.

*You have three series running—"Cannon," "Streets of San Francisco," and "Barnaby Jones"—as well as four pilots, some "Movies of the Week," and other projects in the works. How do you manage to supervise it all?*

In essence, I run a benevolent dictatorship. Everybody has a say in the company. But in the final analysis, I have the responsibility to the network, so I have to make the final decisions.

But we get good ideas from everybody. I surround myself with good people—that's another secret. You should always try to get the best people. You can't learn anything from someone who is dumber than you are. Then you set a climate that they can work well in.

I have a positive viewpoint. I think anybody that has talent and is willing to work hard can make a mark in this business. The Horatio Alger myth still exists in America.

*Like Quinn Martin, Eastman Kodak Company surrounds itself with good people—specialists who can give you the facts about products like Eastman color negative II film 5247. They'll be glad to demonstrate what it can do for you. So give your local Kodak rep a call.*

*And, for a free copy of this and other interviews, send for our booklet.*

*Write: Eastman Kodak Company, Department 640F, Rochester, N.Y. 14650.*



**EASTMAN KODAK COMPANY**  
Atlanta: 404/351-6510/Chicago: 312/654-5300  
Dallas: 214/351-3221/Hollywood: 213/464-6131  
New York: 212/262-7100/San Francisco:  
415/776-6055/Washington: 202/554-5808.

**Lam, Henry W., Jr.**, Pres., Record Plating Corp. Mail: Box 22801, Houston, TX 77027 (M)  
**Reighard, Patton B.**, Univ. of Texas at Austin. Mail: B-207 Colorado Apts., Lake Austin Blvd., Austin, TX 78703 (S)  
**Teoh, Albert, Mgr.**, 2121 Pech No. 6, Houston, TX 77055 (A)  
**Triche, Jr., Richard J. Mgr.**, Video Group, Cameron Iron Works. Mail: 2239 Fairgreen, Missouri City, TX 77459 (A)  
**Watters, Lee D.**, Trinity Univ., 715 Stadium Dr., Bx 1923, San Antonio, TX 78784 (S)  
**Yeager, Paul N.**, KUHT-TV, Ch. 8, 4513 Cullen, Houston, TX 77004 (A)

### MONTREAL SECTION

**Adams, Robert S.**, Concordia Univ. Mail: 164 Mt. Vernon #4, Ville St. Pierre, P.Q., Canada (S)  
**Chauvin, Gilles**, TV Maintenance Mgr., Canadian Broadcasting Corp. Mail: 140 Charles-Aubertin St., Boucherville, PQ, Canada J4B 4P6 (M)  
**Clarke, William G.**, 613 Roosevelt Ave., Ottawa, Ont., Canada K2A 2A4 (A)  
**Collins, Suzanne**, Chf. Serv. Adm., Radio-Quebec, 1000, rue Fullum, Montreal, P.Q., Canada (M)  
**Dumont, Jean-Paul**, Technical Dir., Office De Radio-Telediffusion De Quebec. Mail: P.B. 4, 5 des Cedres, St. Basile-Le-Grand, P.Q., Canada J0L 1S0 (M)  
**Franklin, T. John**, TV Prodn. Trainee, Carleton Univ. Mail: 458 Thessaly Circle, Ottawa, Ont., Canada K1H 5W5 (A)  
**Hasrouni, Youssef**, Electronics Techn., National Film Board of Canada. Mail: 780 Hodge #11, St. Laurent, P.Q., Canada H4N 2A6 (M)  
**Hooper, Michael J.**, Sales Rep., Turnelle Assoc. Ltd. Mail: 1184 Belair St., Templeton, P.Q., Canada (A)  
**Jahanneau, Raymond**, Sec. Treas., Sonimages Inc., 9850 Tolhurst, Montreal, P.Q., Canada H3L 2Z8 (A)  
**Ladouceur, Lionel A.**, Sr. Techn., Film Processing, CJOH-TV, 1500 Merrivale Rd., Ottawa, Ont., Canada (A)  
**McDonough, Kevin**, Carleton Univ. Mail: 153 Nepcan St., Apt. 211, Ottawa, Ont., Canada (A)  
**Mutton, Ross**, Mgr., TV Media Operations, Carleton Univ. Mail: 62 Tarquin Cres., Ottawa, Ont., Canada 2H 8J9 (A)  
**Ouellette, Gilles H.**, Technical Officer, CBC. Mail: 9030 Rochette, St. Leonard, P.Q., Canada H1P 2K2 (M)  
**Ricard, Jacques**, Research Techn./Programmer, National Film Board of Canada. Mail: 9115 Lacordaire, St. Leonard, P.Q., Canada H1R 2B5 (M)  
**Rochon, Jules**, Dir. of Photog. Dept., Quebec Government. Mail: 199 Ave Du Lac Est., Stoneham, P.Q., Canada GOA 4P0 (M)  
**Samson, Bertrand**, Concordia Univ. Mail: 285 Roy St., Coaticook, P.Q., Canada (S)  
**Turner, R.**, Pres., Turnelle Associates Ltd., 17-2 Grenfell Cres., Ottawa, Ont., Canada K2G 0G3 (A)  
**Vasiliou, Basil**, Concordia Univ. Mail: P.O. Box 1233, Station H, Montreal, P.Q., Canada (S)  
**Vegh, Michael**, Service Mgr., Sony of Canada. Mail: 1207 Muir St., Montreal, P.Q., Canada (A)  
**Vinet, Paul J.**, Concordia Univ., A/V Dept., 1455 de Maisonneuve West, Montreal, P.Q., Canada (S)

### NASHVILLE SECTION

**Burton, Darrell W.**, Asst. Dir. of Engrg. for Studio. KET. Mail: 813 Arrowhead Dr., Lexington, KY 40503 (M)  
**Carroll, Richard E.**, Middle Tennessee State Univ. Mail: Villager Apt. G 15, Murfreesboro, TN 37130 (S)  
**Cherepski, Don D.**, Video & Audio Sales, Stanley Communications Co. Mail: 6217 Senate Dr., Little Rock, AR 72209 (A)  
**Dickerson, Roy S.**, Chf. Photog., WREG-TV. Mail: 3818 Maulden Dr., Memphis, TN 38116 (M)  
**Gilbert, Herbert C.**, Maintenance Supvr., WTVF-Channel 5. Mail: Rt. 8, Harper Rd., Clarksville, TN 37040 (M)  
**Rodgers, Bill**, Rodgers Studio, 224 W. Main St., Frankfort, KY 40601 (M)

### NEW ENGLAND SECTION

**Aronson, Michael**, Cable Intern, National Endowment for the Arts. Mail: 35 Hillside Ave., Medford, MA 02155 (A)  
**Carr, Steve B.**, Studio Engr., WSMV-TV. Mail: 44 Powderhouse Blvd., 3 fl., Somerville, MA 02144 (A)  
**Cooper, Russell H.**, Studio Techn. WCVB-TV. Mail: 161 Tudor Rd., Needham, MA 02192 (A)  
**Dyett, Edmond G., Jr.**, Asst. to the Pres., Super 8 Sound, Inc. Mail: 59 Prince St., W. Newton, MA 02165 (M)  
**Edgington, Nicholas**, Clark Univ. Mail: 1 Rough Ter., Wore, MA 01605 (S)  
**Ellowitz, Alice**, Boston Univ. Mail: 35 Cummings Rd., #2, Brookline, MA 01246 (S)  
**Fasciano, Peter**, Videotape Techn., WSMW-TV. Mail: 98 Country Club Blvd., Worcester, MA 01605 (M)  
**Goudreau, Raymond A.**, Asst. Chf. Engr., WWLP-TV. Mail: 208 Mueller Rd., Holyoke, MA 01040 (M)  
**Greer, Robert**, MIT, Branch Post Office, Cambridge, MA 02139 (S)  
**Gurkoff, Jeffrey A.**, Pres., Cinema 14, Inc. Mail: 14 Hunnewell Ave., Brighton, MA 02135 (A)  
**Kauffman, Ross B.**, Chf. Engr., WCVB-TV. Mail: Seven Claremont Park, Boston, MA 02118 (M)  
**McDaniel, Wyatt E.**, 39 Village Green North, East Providence, RI 02915 (M)  
**McKinley, Paul R.**, Technical Supvr., A.V. Dept., Bose, Inc. Mail: 11 Jennings Pond Rd., Natick, MA 01760 (A)  
**Merhar, Milan J.**, Engr., WGBH Educational Foundation. Mail: 36 Oakland Rd., Brookline, MA 02146 (M)  
**Nussbaum, Nicholas**, P.O. Box 68-MIT Branch, Cambridge, MA 02139 (A)  
**Skerry, Jr., Michael F.**, Product Mgr., GTE-Sylvania, 100 Endicott St., Danvers, MA 01923 (M)  
**Spruill, D. Brian**, Sls. & Engrg. Rep., Eastman Kodak Co. Mail: 46 Cranberry Dr., Duxbury, MA 02332 (M)  
**Warwick, James L.**, Vice Pres., Sound Div., Capron Lighting Co., Inc. Mail: 27 Country Dr., Beverly, MA 01915 (M)

### NEW YORK SECTION

**Ackerman, Benson**, Branch Scientist, CBS, Inc. Mail: 404 Park Ave., Leonia, NJ 07065 (M)  
**Adelman, Richard M.**, Television and Radio, 621 Ave. Z, Brooklyn NY 11233 (S)  
**Alson, Allen**, Brooklyn College. Mail: 1143 Beach 9, Far Rockaway, NY 11691 (S)  
**Amico, Jr., Salvatore J.**, Supvr. Film Dept., WPIX TV. Mail: 10 Ellis Dr., Syosset, NY 11791 (M)  
**Ardolino, Paul**, Syracuse Univ. Mail: 276 Riverside Dr., #9C, New York, NY 10025 (S)  
**Arnold, Orion M.**, Dir. RF Engrg., CBS, Inc. Mail: 2 Sleepy Hollow Dr. Ho-Ho-Kus, NJ 07423 (M)  
**Arnouts, Jack**, TV Engr., Culinary Institute of America. Mail: 303 Cooper Rd., Poughkeepsie, NY 12603 (A)  
**Arrien, Maryann**, Columbia Univ. Mail: 23-29 31 Rd., Astoria NY 11106 (S)  
**Barron, Jr., Daniel J.**, 111 Lancaster Rd., Colonia, NJ 07067 (A)  
**Becker, Howard**, Mot. Pic. Projectionist, United Artists Theatres. Mail: 100-22 Elgar Pl., Apt. 22J, Bronx, NY 10475 (A)  
**Beckman, Michael**, School of Visual Arts. Mail: 140 W. 16 St., New York, NY 10011 (S)  
**Berlin, David H.**, Columbia College. Mail: 495 West End Ave., Apt. 6B, New York, NY 10024 (S)  
**Bisignano, Rich**, New York Institute of Technology. Mail: 322 Broughton Ave., Bloomfield, NJ 07003 (S)  
**Bongiorno, Donald**, Sec./Treas., Suburban Chemical Co., 55 W. Peel St., Paterson, NJ 07524 (A)  
**Bruce, David I.**, Columbia Univ. Mail: 100 W. 15 St., #1-E, New York, NY 10011 (S)  
**Bruce, Maryellen O.**, Columbia Univ. Mail: 100 W. 15 St., New York, NY 10011 (S)  
**Cannata, James J.**, NYU. Mail: 17 Annmarie Pl., Yonkers, NY 10703 (S)  
**Cavanaugh, John D.**, Gen. Sales Mgr. Mail: Techni-  
 color, 321 W. 44 St., New York, NY 10036 (M)  
**Clarke, Michael F.**, Film Prodn. Officer, U.N. Children's Fund, 866 United Nations Plaza, New York, NY 10017 (A)  
**Clinton, Irving J.**, Univ. of the Street. Mail: 640 E. 6 St., Apt. 6, New York, NY 10009 (S)  
**Consuegra, Helena M.**, Columbia Univ. Mail: 211 E. 70 St., New York, NY 10021 (S)  
**Cooper, Michael M.**, Product Sls. Mgr., 8mm Systems, Fuji Photo Film U.S.A. Mail: 2372 Longfellow Ave., Scotch Plains, NJ 07076 (M)  
**Coyne, Thomas R.**, Columbia Univ. Mail: 292 Riverside Dr., Rm. 4-A, New York, NY 10025 (S)  
**Craddock, John**, Post Prodn. Supvr., Learning Corp. of America. Mail: 250 W. 82 St., New York, NY 10024 (A)  
**Culp, Timothy**, Brooklyn College. Mail: 1553 Ocean Ave., Brooklyn, NY 11230 (S)  
**Damon, James G.**, Mgr., Video Communications, IBM Corp. Mail: 7 Robinson Dr., Stamford, CT 06905 (M)  
**Danois-Marica, Etienne**, McGill Univ. Mail: 120 E. 34 St., Apt. 20G, New York, NY 10016 (S)  
**De, Ruby**, Engr., CBS Inc. Mail: 3 Glen Oak Dr., East Windsor, NJ 08520 (A)  
**Decker, Saul M.**, Mgr., Laser Film Recorder, CBS Technology Center. Mail: 86 Rolling Wood Dr., Stamford, CT 06905 (M)  
**Del Coro, Ralph J.**, Pres., Modern/Mass Media, Inc., 315 Springfield Ave., Summit, NJ 07901 (M)  
**Diaz, Ramon E.**, Columbia Univ. Mail: c/o K. Calamaras, 245 E. 25 St., New York, NY 10010 (S)  
**Doherty, David J.**, Chf. Engr., TV Studio, New Jersey Bell Telephone. Mail: 1201 Ocean Ave., Apt. 60, Sea Bright, NJ 07760 (M)  
**Dorozynsky, Daniel**, City College of NY. Mail: 3435 Giles Pl., Bronx, NY 10463 (S)  
**Drummond, John D.**, Supvr., Trade & Tech. Edu., Center for Career & Occupational Edu. Mail: 120-43 194 St., St. Albans, NY 11412 (M)  
**Ebell, William C.**, Sr. Sales Engr., Ampex Corp. Mail: 117 Shady La., Morristown, NJ 07960 (A)  
**Engel, Lawrence B.**, Instructor in Film, Columbia Univ. Mail: 322 W. 104 St., Apt. 4F, New York, NY 10025 (A)  
**Ferguson, Ralph G. I.**, Columbia Univ. Mail: 434 W. 120 St., #9F, New York, NY 10027 (S)  
**Finlay, Gregg W.**, Nat'l Sls. Adm. & Sales Coord., Sony Corp. of America. Mail: 89 Smith St., Lynbrook, NY 11563 (A)  
**Fisher, Philip C.**, NYU. Mail: 2965 Ave. Z, Brooklyn, NY 11235 (S)  
**Flaherty, Patrick J.**, 19 Murray Ave., Port Washington, NY 11050 (S)  
**Fluger, Eric**, NYU. Mail: 138 Orton Rd., West Caldwell, NJ 07006 (S)  
**Francisco, Patricia**, Columbia Univ. Mail: 245 W. 4 St., New York, NY 10014 (S)  
**Frankel, Bruce H.**, NYU. Mail: 350 W. 18 St., 6B, New York, NY 10011 (S)  
**Galbraith, Huxley H., Jr.**, Broadcast Electronics Techn., CBS, Inc., 524 W. 57 St., Rm. 1E2B4, New York, NY 10019 (A)  
**Galvin, Robert J.**, Vice Pres., TV Network Operations, NBC, 30 Rockefeller Center, New York, NY 10020 (M)  
**Gattuso, Jeanne M.**, Chemical Lab. Techn., Eastman Kodak Co. Mail: 1724 Holly Rd., North Brunswick, NJ 08902 (A)  
**Gendler, Sanford S.**, York College. Mail: 223-07 Manor Rd., Queensvillage, NY 11427 (S)  
**Goldblatt, Michael N.**, Syracuse Univ. Mail: 716 Bruce Dr., E. Meadow, NY 11554 (S)  
**Graham, David R.**, Projectionist, Local 486. Mail: P.O. Box 243, Enfield, CT 06082 (A)  
**Halm, Margaret**, CCNY, 300 E. 71 St., New York, NY 10021 (S)  
**Harris, Brenda**, Jersey City State College, 73 Clerk St., Jersey City, NJ 07305 (S)  
**Hevey, Wilfrid A.**, Pres., Show Lighting Corp., 26 S. George St., Meriden, CT 06450 (A)  
**Hirschorn, Jack**, Brooklyn College. Mail: 986 E. 19 St., Brooklyn, NY 11230 (S)  
**Hoberman, James**, Columbia Univ. Mail: 523 Broadway, New York, NY 10012 (S)  
**Hoffman, Kenneth**, NYU. Mail: 12 Hill St., Morristown, NJ 07960 (S)

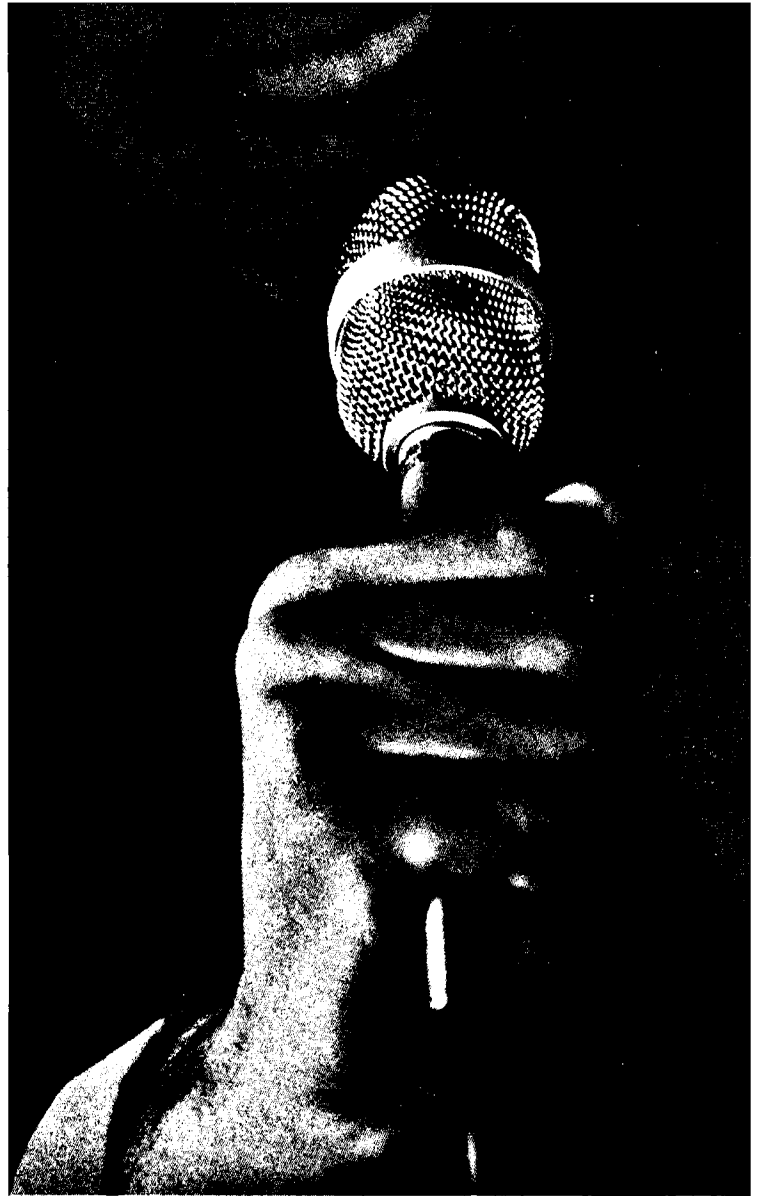

**Handling all this is a lot easier. When you can take this for granted.**

**The new Electro-Voice DS35  
Single-D Cardioid.**

The performance mike that makes your job go a lot more smoothly, no matter how big a job you've got to handle.

**Greater gain before feedback:**

Check it out yourself. Work your system with a DS35. Compare the level you can get before feedback with that of any competitive mike. One big reason is the flat response provided by our unique Volumetric<sup>®</sup> laminated diaphragm—designed with the aid of laser holography.

**Cleaner highs, wider response:**

The exclusive diaphragm design assures linear motion to reproduce more accurately, especially at frequency extremes. And state of the art port design means the best off-axis response of any single-D microphone.

**More boost to the bass:**

Used close up, the DS35 supplies lots of the bass boost (proximity effect) some entertainers want.

**Stronger and quieter:**

The rugged steel case withstands the toughest

abuse—even remotes and road tours. The pneumatic shock mount absorbs hand and cable noise. The integral blast filter squelches "P-popping." And it's protected by the famous E-V professional warranty.

DS35...\$99.00 Suggested Resale Net. Slightly Higher in Western States.

**Electro-Voice<sup>®</sup>**

Dept. 271SM, 685 Cecil St.  
Buchanan, Michigan 49107



- Holmes, John, A-V Engr.,** Optimedia Systems, Inc. Mail: 215 Parsippany Rd., Whippany, NJ 07981 (M)
- Hower, Jeffrey,** Audio Visual Techn., B. B. D. & O. Advertising. Mail: 7003 B Park Dr., East, Flushing, NY 11367 (A)
- Hubbell, David C.,** Eastman Kodak Co., 1133 Avenue of the Americas, New York, NY 10036 (M)
- Hurst, Jr., R. Norman,** Steven Institute of Technology. Box S-607, Castle Point Station, Hoboken, NJ 07030 (S)
- Ian, Andrew,** Electronic Engr., Design, Thomson CSF Labs, 37 Brown House Rd., Stamford, CT 06902 (M)
- Jackson, Chris,** School of Visual Arts. Mail: 232 E. 13 St., 3B, New York, NY 10003 (S)
- Jones, Rodney R.,** Sales & Engr. Rep., Eastman Kodak Co. Mail: 169 W. 76 St., Apt. 1B, New York, NY 10023 (M)
- Juchnowycz, Stefan,** Project Engr., Ingalane, Saddle Hill Rd., Stamford, CT 06903 (M)
- Kegl-Bognar, Desi,** Producer/Const., AFI-Atelier Films Inc. Mail: P.O. Box 8 FW, 222 Primrose Ave., Fleetwood, NY 10552 (M)
- Kersten, Charles J.,** Sls. & Engr. Rep., Eastman Kodak Co. Mail: 505 River Rd., Bogota, NJ 07603 (M)
- Klein, Elliot,** Ithaca College. Mail: 24 Woodland Pl., Great Neck, NY 11021 (S)
- Kreeger, Lawrence J.,** Account Exec., EUE/Screen Gems. Mail: 47 Lincoln Rd., Scarsdale, NY 10583 (M)
- Kronick, David C.,** Sls. Mgr., Agfa-Gevaert, Inc., 275 North St., Teterboro, NJ 07608 (A)
- Kubiak, S. Allison,** Quality Control Officer, United Nations. Mail: 64-50 233 St., Bayside, NY 11364 (M)
- Lertsuphanont, Piyagul,** Columbia Univ. Mail: 419 W. 114 St., Box #115, New York, NY 10025 (S)
- Leviit, Harold H.,** Pres., The Media Man, Inc., 313 Rutland Ave., Teaneck, NJ 07666 (A)
- Levin, David,** Columbia Univ. Mail: 59 Thompson St., Apt. 1, New York, NY 10012 (S)
- Levy, Bern,** Angenieux Corp. of America, 1500 Ocean Ave., Bohemia, NY 11716 (A)
- Lisi, Steve,** Asst. Tech. Mgr., Agfa-Gevaert. Mail: Laurel Dr., Oak Ridge, NJ 07438 (A)
- Loftis, Norman J.,** Columbia Univ. Mail: 185 Washington Park, Brooklyn, NY 11205 (S)
- Lupianez, Orlando,** Sr. Project Engr., CBS. Mail: 67-09 Blvd. East, Guttenberg, NJ 07093 (M)
- Lydon, Francis A.,** Sr. Engr., Philips Audio Video Systems Corp. Mail: 188 Clark St., Bloomington, NJ 07403 (M)
- MacDonald, David K.,** Gen Mgr., Broadcast Div., Sony Corp. of America. Mail: Vittorio Ct., Park Ridge, NJ 07656 (M)
- Maitland, Richard H.,** Pres., Westec Audio. Mail: 100 Riverside Dr., 5B, New York, NY 10024 (M)
- Markunas, Christina L.,** Columbia Univ. Mail: 110 Sullivan St., Apt. 6-G, New York, NY 10012 (S)
- Marx, Ronald,** McGraw Hill. Mail: 7400 Shorefront Parkway, Apt. 7P, Rockaway Beach, NY 11692 (S)
- Mascari, Charles M.,** Asst. Supvr. Tech. Operator, CBS. Mail: 217 Chelsea Rd., White Plains, NY 10603 (M)
- May, Edward,** Instructor, NYU. Mail: 305 W. 74 St., New York, NY 10023 (M)
- McCoy, Carol D.,** Prodn. Mgr., Windsor Total Video. Mail: 2245 Randall Ave., Bronx, NY 10473 (A)
- McClimont, John,** Sales Mgr., Conrac Corp. Mail: 1 Fifth Ave., New York, NY 10003 (A)
- Megalos, William,** Columbia College. Mail: 242 W. 16 St., Apt. 5F, New York, NY 10011 (S)
- Mele, Ronald J.,** Projectionist, Sonderling Brothers Corp. Mail: RFD #2, Brick Rd., New Hartford, CT 06057 (A)
- Meyer, Kerry L.,** Columbia Univ. Mail: 306 W. 109 St., #4C, New York, NY 10023 (S)
- Midgett, Roger S.,** Columbia Univ. Mail: 517 W. 113 St., #84, New York, NY 10025 (S)
- Mintz, Arnold E.,** Engr., WOR-TV. Mail: 67-10 108 St., Forest Hills, NY 11375 (M)
- Montanti, Linda M.,** Columbia Univ. Mail: 127 W. 79 St., Apt. 12A, New York, NY 10024 (S)
- Mucia, John J.,** Chf. Engr., Columbia TV. Mail: Columbia University, 803 Jay Hall, New York, NY 10027 (A)
- Nalaboff, Steve,** New York Univ. Mail: 2162 Jackson Pl., N. Bellmore, NY 11710 (S)
- Ohlandt, Herbert C.,** VTR Project Supvr., ABC. Mail: 244 Elmwood, Glen Rock, NJ 07452 (M)
- Opel, M. Ronald,** Securities Analyst, Kidder, Peabody & Co., Inc., 10 Hanover Sq., New York, NY 10005 (A)
- Palewski-Brumbach, Stephanie,** Columbia Univ. Mail: 11 W. 18 St., New York, NY 10011 (S)
- Paone, Robert,** Asst. Cameraman, I.A.T.S.E. Mail: 335 Harold St., Staten Island, NY 10314 (A)
- Parks, Paul F.,** Design Mgr., Components Corp. Mail: 156 Mt. Ave., Hackettstown, NJ 07840 (M)
- Pastorelle, Peter J.,** Pres., Peter Pastorelle Productions Inc., 50 West St., Suite C9A, Harrison, NY 10528 (A)
- Phelan, Donald J.,** Sls. Mgr./Film Dir., Compix of New York. Mail: 114 Abbott St., North Massapequa, NY 11758 (M)
- Pollicastro, Anthony,** Rutgers Newark College. Mail: 310 Lafayette St., Newark, NJ 07105 (S)
- Rainey, Jr., Robert J.,** Engr., Datatek Corp., 1166 W. Chestnut St., Union, NJ 07083 (A)
- Rebo, Barry,** 148 E. 28 St., New York, NY 10016 (A)
- Rieur, Renan J.,** Ithaca College. Mail: 10 Terrace Ave., Riverside, CT 06808 (S)
- Robinson, CeOtis,** Columbia Univ. Mail: 4-6 W. 101 St., Apt. 49A, New York, NY 10025 (S)
- Ronquist, Steven,** School of Visual Arts. Mail: 238 E. 9 St., New York, NY 10003 (S)
- Rosenthal, Martin J.,** Columbia Univ. Mail: 301 E. 75 St., New York, NY 10021 (S)
- Rovics, Trudie R.,** NYU. Mail: 405 E. 16 St., Apt. #3G, Brooklyn, NY 11226 (S)
- Rubenstein, Julian,** SUNY at Buffalo. Mail: 590 West End Ave., New York, NY 10024 (S)
- Saetta, Janet,** School of Visual Arts. Mail: 1099 Waverly Ave., Holtsville, NY 11742 (S)
- Samara, Renee,** 272 82 St., Brooklyn, NY 11209 (S)
- Sanis, Christie J.,** New York Institute of Technology. Mail: 25-10 46 St., Astoria, NH 11106 (S)
- Saunders, Sr., William S.,** Sales Rep., Northeast Region, FilmLab Service, Inc. Mail: 836 Tilden St., Apt. 1D, Bronx, NY 10467 (A)
- Schultz, Gary,** Engr., CBS Television Network. Mail: 15-02 Hunters Glen Dr., Plainsboro, NJ 08536 (A)
- Schuster, John,** Engr., Sonivision Corp. Mail: 16 Hillandale Ave., North White Plains, NY 10603 (M)
- Schweitzer, Ira,** Video Tape Engr., Romex Productions Inc. Mail: 1237 Hempstead Ave., South Hempstead, NY 11550 (M)
- Segawa, Ichiro,** Product Mgr., Sony Corp. of America, 47-47 Van Dam St., Long Island City, NY 11101 (M)
- Seidel, Robert P.,** Video/Video Design Engr., CBS Television Network. Mail: Princeton Arms South II, Apt. 123, Cranbury, NJ 08512 (A)
- Serra, Eljo,** Asst. to the Pres., Zanussi Corp. of America, 79 Madison Ave., New York, NY 10016 (A)
- Severo, Carlo A.,** Sony Corp. Mail: 189 Rumsey Rd., Yonkers, NY 10705 (M)
- Sguiglia, John P.,** Columbia College. Mail: 318 W. 75 St., 2B, New York, NY 10023 (S)
- Shewchuk, Robert,** Producer/Dir., ATT Corp. Mail: 581 Patten Ave., Apt. 57, Longbranch, NJ 07740 (A)
- Sidas, Walter,** Sr. Project Engr., CBS, Inc. Mail: 120-21 91 Ave., Richmond Hill, NY 11418 (M)
- Silver, Gary,** Sound Recordist, Acrolog Productions. Mail: 1418 E. 15 St., Brooklyn, NY 11230 (A)
- Singer, Warren,** Vice Pres., Thomson-CSF, Inc. Mail: 48 Martindale Rd., Short Hills, NJ 07078 (A)
- Smith, David E.,** NYU-School of Arts. Mail: 288 Clinton St., Brooklyn, NY 11201 (S)
- Sokira, Thomas J.,** Vice Pres., Res. & Dev., Multi-Track Magnetics Inc. Mail: 69 Manor Dr., Cheshire, CT 06410 (M)
- Sonnenfeld, Barry,** NYU. Mail: 158 E. 7 St., New York, NY 10009 (S)
- Sprague, T. R.,** Procurement Engr., ABC. Mail: P.O. Box 774, Ansonia Station, 1990 Broadway, New York, NY 10023 (M)
- Stein, Craig B.,** School of Visual Arts. Mail: 289 Southwood Circle, Syosset, NY 11791 (S)
- Stockage, Steven,** Columbia Univ. Mail: 530 Riverside Dr., Apt. 2H, New York, NY 10027 (S)
- Stone, Alan,** Columbia Univ. Mail: 2250 83 St., Brooklyn, NY 11214 (S)
- Stow, Rupert L.,** Asst. Dir., Tech. Facilities Planning, CBS Inc., 51 W. 52 St., New York, NY 10019 (M)
- Sturgeon, Gary R.,** Field Service Engr., Ampex Corp. Mail: 44 Center Grove Rd., Apt. R6, Dover, NJ 07801 (A)
- Szyjewicz, Michael,** NYU. Mail: 109 Waverly Pl., New York, NY 10011 (S)
- Tabcum, Sarote,** Video Engr., Sorfy Corp. of America. Mail: 141 Campbell Ave., Tappan, NY 10983 (M)
- Tanner, Craig K.,** Engr., CBS TV Network. Mail: 42 Highland Rd., Glen Rock, NJ 07452 (A)
- Taub, Marshall,** Principal Biomedical Photographer, College of Medicine & Dentistry of NJ. Mail: 81 West End Ave., Brooklyn, NY 11235 (M)
- Tenten, Robert C.,** Dir. of Engr., Home Box Office. Mail: 165 Russell Rd., Fanwood, NJ 07023 (M)
- Toker, Joav,** Columbia Univ. Mail: 42 Jane St., New York, NY 10014 (S)
- Tokpah, Joseph V. J.,** Pennco Tech. Mail: 129 Prospect Pl., Brooklyn, NY 11217 (S)
- Tolerico, Joseph B.,** Electronic Engr., Turner Engineering. Mail: 660 Edwards Rd., Parsippany, NJ 07054 (A)
- Tomlin, Fergus,** Columbia Univ. Mail: 431 Riverside Dr., JJ Woodbridge Hall, New York, NY 10027 (S)
- Torres, Jack,** Projectionist/Technician, American Museum of Natural History. Mail: 501 Ocean View Ave., Brooklyn, NY 11235 (A)
- Tortorete, James,** Engr., American Telephone & Telegraph. Mail: 135 Schepis Ave., Saddle Brook, NJ 07662 (M)
- Velazquez, Paul N.,** Columbia Univ. Mail: 18-29 21 Dr., Long Island City, NY 11105 (S)
- Ward, William F.,** Columbia Univ. Mail: 276 Riverside Dr., New York, NY 10025 (S)
- Wasser, Frederick,** Columbia Univ. Mail: 5517 Fieldston Rd., Bronx, NY 10471 (S)
- Weng, Hugo,** Agfa-Gevaert, Inc., 275 North St., Teterboro, NJ 07608 (A)
- Wessot, Malcolm H.,** Design Techn., Chatham Antenna Services, 51 Austerlitz St., Chatham, NY 12037 (A)
- Wicks, Wayne L.,** Asst. Mgr., TV, ABC. Mail: 241 Oakland Ave., Miller Place, NY 11764 (M)
- Willtorp, Marianne,** c/o Eckemyr, 135 Central Park West, Penthouse North, New York, NY 10023 (S)
- Wilson, Anton F.,** Vice Pres., Anton/Bauer, Inc. Mail: 823 E. Broadway, Milford, CT 06460 (M)
- Winterburn, Ted,** Supvr., Film Editor, Jeff Dell Editorial. Mail: 103 Old Lake St., White Plains, NY 10604 (A)
- Wood, Peter,** Columbia Univ. Mail: 500 Riverside Dr., Rm. 1010, New York, NY 10027 (S)
- Yamagishi, Jin,** Asst. Mgr., Sony Corp. of America, 9 W. 57 St., New York, NY 10019 (A)
- Yannotti, Salvatore M.,** School of Visual Arts. Mail: 628 E. 14 St., Apt. 15, New York, NY 10009 (S)

## OHIO SECTION

- Ashton, Jr., Theodore,** Cathedral Teleproductions. Mail: 4379 Elmhurst, Stow, OH 44224 (A)
- Bisson, Jr., Gene E.,** Producer, Bisson Film Productions, 10671 Lawndale Dr., Parma Heights, OH 44130 (M)
- Chapman, Jr., John M.,** Northeastern Rep., Klopff Audio/Video Co. Mail: 11831 Pearl Rd., Rm. 410, Strongsville, OH 44136 (M)
- Clark, Thomas P.,** 4618 Redfern Rd., Parma, OH 44134 (M)
- Creve, Hilton,** Case Western Reserve Univ. Mail: 2496 Milton Rd., University Heights, OH 44118 (S)
- Dwynn, Bruce S.,** Splst., Cleveland Public School. Mail: 4144 W. 56 St., Cleveland, OH 44144 (M)

# *Masterpiece of Accomplishment*

Producer/Director  
DALE BELL  
Sound Supervisor  
JOHN BUTLER  
Sound and Picture  
NORRIS BROCK  
Sound Service by  
RYDER SOUND SERVICES, INC.  
Production Manager  
JOE SEAMANS  
Produced by  
WQED/ Pittsburgh and the  
National Geographic Society

## VOYAGE OF THE HOKULE'A

We salute  
the dedication  
and spirit  
that resulted  
in this inspired  
undertaking.

Space being  
at a premium  
aboard the Hokule'a  
it was necessary  
that one man  
handle both sound  
and picture  
simultaneously.

NAGRA SNN  
met the challenge.

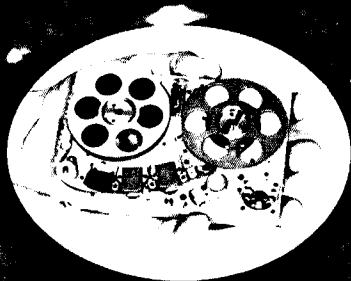

Our pride in the selection of the NAGRA SNN  
to compliment this great effort is now more than justified  
in the resulting performance of superior capability  
and high level professional product reliability under  
the most extreme conditions.

United States Distribution - Service - Sales **NAGRA MAGNETIC RECORDERS, INC. NEW YORK**  
West Coast Sales - Service & Technical Center **RYDER MAGNETIC SALES CORP. HOLLYWOOD**  
Available in Canada **BRAUN ELECTRIC CANADA, LTD.**

**Kuca, Charles J.**, Chf. Engr., Telecommunications, Wright State Univ. Mail: 7320 Wilmington Pike, Dayton, OH 45459 (M)

**Lentz, Paul E.**, Chf. Engr., Cosmos Broadcasting Corp., 604 Jackson, P.O. Box 715, Toledo, OH 43695 (M)

**Lynch, F. Dennis**, Associate Professor, Film, Cleveland St. Univ., Dept. of Communication, Cleveland, OH 44115 (M)

**Mancino, Anthony J.**, Chf. Photog., WYTV-TV, Mail: 1402 Doncaster Dr., Youngstown, OH 44511 (M)

**Mc Cartha, B. Bland**, TV Field Engr., Tektronix, Inc., 501 Progress Rd., Dayton, OH 45449 (M)

**Meyers, Edson B.**, Photo Techn., Ares, Inc. Mail: 4975 Schoolhouse Rd., Port Clinton, OH 43452 (A)

**Nocifora, Jr., Charles**, Engrg. Tech., Cathedral of Tomorrow, Mail: 15745 Jug St., Burton, OH 44021 (M)

**Owen, John B.**, Chf. Engr., Taft Broadcasting Co.-WTVN-TV, Mail: 153 E. Kelso Rd., Columbus OH 43202 (M)

**Shirley, Laurence W.**, Ohio Univ. Mail: Athens International Film Festival, Film Festival Office, Lindley, Hall, Athens, OH 45701 (S)

**Stegmiller, Robert F.**, Factory Productions, Mail: 185 N. Terrace Ave., Columbus, OH 43204 (M)

**Strach, Art**, Mgr., A/V & Photography, The General Tire & Rubber Co. Mail: 1 General St., Akron, OH 44329 (A)

**Ungar, Donald A.**, Pres., Ungar Motion Pictures, 4800 Woodbury Hills, Parma, OH 44134 (M)

**Wilkinson, Thomas F.**, Mgr., Media Engrg. Div., Cuyahoga Community College, Mail: 5805 Bower Ave., Cleveland, OH 44127 (A)

#### PACIFIC-NORTHWEST SECTION

**Anderson, Lonnie O.**, Operations Mgr., Access Television South, Mail: 23 Holly St., N.W., Calgary, Alta., Canada T2K 2C7 (M)

**Backhouse, George**, Assoc. Dir., Access Alberta, Mail: RR1, Site 4, Box 5, St. Albert, Alta., Canada T8N 1M8 (M)

**Cox, John W.**, Video Techn., Battelle Northwest, Mail: 1115 Willard, Richland, WA 99352 (M)

**Dripchak, Marcia L.**, Univ. of Washington, Mail: 321 Boylston East, #103, Seattle, WA 98102 (S)

**Elfstrom, Kerry M.**, Pres., Geoid Media Services Ltd, Mail: 2475 Manitoba St., Vancouver, BC, Canada V5Y 3A4 (M)

**Errington, David**, Dir., Access T.V. North, Alberto Educational Communications Corp, Mail: #2607 11135 83 Ave., Edmonton, Alta., Canada (M)

**Grinke, Arthur L.**, Audio Visual Producer, B. C. Railway, Mail: 428 E. 19, North Vancouver, BC, Canada (A)

**Hunchak, Mike**, Cinematographer, A-V Enterprises, 7615 154 St., Edmonton, Alta., Canada T5R 1R6 (M)

**Kay, Alan A.**, Mgr., Film Unit, Crown Zellerbach Canada Ltd., Film Unit, 1345 Vukan Way, Richmond, BC, Canada V6V 1K4, (A)

**Maitz, John J.**, TV Techn., Sony of Canada Ltd, Mail: #315-9700 Bonaventure Dr., SE, Calgary, Alta., Canada T2J 0E6 (A)

**McGechaen, Sandy**, Coordinator, University of B.C., Canada, Mail: 1793 Ralph St., North Vancouver, BC, Canada V7K 1V8 (M)

**Nason, Robert H. B.**, Instructor, B. C. Institute of Technology, Mail: 3911 Carrigan Ct., Apt. 110, Burnaby, BC, Canada V3N 4J7 (A)

**Nelson, Arnold W.**, Radio-Television Broadcasting, Mail: 1736 Belmont #514, Seattle, WA 98122 (S)

**Porochuk, William N.**, Central Mgr., Access Alberta, Mail: Box 598, Cochrane, Alta., Canada T0L 0W0 (M)

**Quinn, John R.**, Technical Supvr., Univ. of Calgary, Mail: 35 A. St., N.W., #903, Calgary, Alta, Canada T2N 3A5 (M)

**Schneider, Jerry J.**, Chf. Cameraman, King Broadcasting Co, Mail: 1501 SW Jefferson St., Portland, OR 97201 (M)

**Speer, Richard J.**, Animation Programmer, NW Cinema Specialists, 1201 Dexter Ave. N., Seattle, WA 98109 (A)

**Thomas, Allan F.**, Acting Chief Theatre Inspector, Alberta Government, Dept. of Labor, Mail: RR #8, Postal Station D, Edmonton, Alta., Canada T5L 4H8 (A)

#### PHILADELPHIA SECTION

**Address, Eric R.**, Chf. Engr., E. J. Stewart, Inc. Mail: 341 Windsor Park La., Broomall, Haverstown, Pa. 19083 (M)

**Agard, Richard**, Temple Univ. Mail: 5739 N. Fairhill St., Philadelphia, PA 19120 (S)

**Arnett, Keith E.**, Sound Techn., McCarter Theatre Co, Mail: D-15 Devonshire Dr., Cranbury, NJ 08512 (A)

**Bogos, Stewart L.**, Temple Univ. Mail: 522 S. 5 St., Philadelphia, PA 19147 (S)

**Burba, Thomas A.**, Filmstrip Lab. Dir., Educational Communications, Inc., 37 West Ave., Box 56, Wayne, PA 19087 (A)

**Cardell, Marijane**, Temple Univ. Mail: 1716 Pine St., Philadelphia, PA 19103 (S)

**Carroll, David B.**, Temple Univ., Johnson Hall 535, Philadelphia, PA 19122 (S)

**Carroll, Timothy D.**, Radio TV Film, Mail: 19 W. Tulphocken St., Philadelphia, PA 19144 (S)

**Caulfield, John**, Temple Univ. Mail: 210 S. Almonesson Ave., Deptford, NJ 08046 (S)

**Cerino, Michael R.**, Temple Univ. Mail: 38 Cherry St., Willowgrove, PA 19090 (S)

**Clark, Allen D.**, Temple Univ. Mail: 63 Bertha St., Feasterville, PA 19047 (S)

**Curran, Susan M.**, Temple Univ. Mail: 2004 Lombard St., Philadelphia, PA 19146 (S)

**Daly, William J.**, Temple Univ. Mail: 228 Rockingham Rd., Rosemont, PA 19010 (S)

**De Marco, Richard**, Pres., Dick De Marco Directions, 1445 N. Hills Ave., Willow Grove, PA 19090 (M)

**Dinkin, David P.**, Temple Univ. Mail: 4137 Roosevelt Blvd., Philadelphia, PA 19124 (S)

**Driggs, Mario F.**, Temple Univ. Mail: 2050 N. Hancock St., Philadelphia, PA 19122 (S)

**Everett, Mark J.**, Systems Engr., Pierce Phelps, Inc. Mail: 6670 Lincoln Dr., Philadelphia, PA 19119 (M)

**Falls, Roy M.**, 22 Nancy Dr., Havertown, PA 19083 (A)

**Farcus, Henry M.**, Temple Univ. Mail: 1330 W. Rockland Ave., 2 Fl., Philadelphia, PA 19141 (S)

**Feist, Richard E.**, Princeton Univ. Mail: 4N Edwards Hall, Princeton, NJ 08540 (S)

**Feria, Fredericko**, Temple Univ. Mail: 388 E. Upsal St., Philadelphia, PA 19119 (S)

**Gaughan, Richard D.**, Imagery, Mail: 401 Main St., Riverton, NJ 08077 (M)

**Glassmire, Charles M.**, Dir.-Film Dept., Robert Morris College, Narrows Run, Coraopolis, PA 15108 (M)

**Gurley, Thomas M.**, Engr.-TV Studio & Control Equip., RCA Corp. Mail: 48D Maplewood Dr., Maple Shade, NJ 08052 (M)

**James, Richard**, Temple Univ. Mail: 1719 Wakeling St., Philadelphia, PA 19124 (S)

**Johnson, Joseph F.**, Temple Univ. Mail: 134 Ritner St., Philadelphia, PA 19148 (S)

**Kimberg, Joseph**, Temple Univ. Mail: 101 Conshohocken State Rd., Bala Cynwyd, PA 19004 (S)

**Kimpland, Roger**, Technical Dir., St. Joseph's Hospital, Mail: 2250 Alsace Rd., Apt. B-3, Reading, PA 19604 (A)

**Kirschner, Larry**, Temple Univ. Mail: 2053 Brandywine St., Philadelphia, PA 19130 (S)

**Kurtz, Mitchell**, Technical Dir., McCarter Theatre Co, Mail: 7 Witherspoon St., Princeton, NJ 08540 (M)

**LaValley, John W.**, Temple Univ. Mail: 411 Hogeand Rd., Southampton, PA 18966 (S)

**Loomis, Brian D.**, Temple Univ. Mail: P.O. Box 586, Brown Mills, NJ 08015 (S)

**Lorek, Stanley**, Engrg. Supvr., WPUI-TV, Mail: 7200 Cottage St., Philadelphia, PA 19135 (M)

**Maslin, Alan M.**, Engr., WPVI-TV, Mail: 2736 Taunton St., Philadelphia, PA 19152 (A)

**Mathis, Jay W.**, Mgr., Tech. Oper., CBS, WCAU-TV, Mail: 509 Germantown Pike, Lafayette Hill, PA 19444 (M)

**McVicker, Lauri**, Temple Univ. Mail: 2101 Chestnut St., Apt. 317, Philadelphia, PA 19103 (S)

**Mitchell, Stephen H.**, Sls. & Engrg. Rep., Eastman Kodak Co. Mail: Forsythe Rd., RD#2, Valencia, PA 16059 (S)

**Muderick, Michael**, Audio Visual Coordinator, Penn Mutual Life Insurance Co., Independence Square South, Philadelphia, PA 19172 (M)

**Nemiroff, Sue**, Temple Univ. Mail: 1417 Magee Ave., Philadelphia, Pa 19111 (S)

**Persing, Kenneth**, Temple Univ. Mail: 4433 Sansom St., Philadelphia, PA 19104 (S)

**Schnuelle, David L.**, Asst. Chf. Engr., Television Production Center, Mail: 415 Stratton La., Pittsburgh, PA 15306 (M)

**Sherwood, Stephen E.**, Temple Univ. Mail: 511 Bradford Rd., Oreland, PA 19075 (S)

**Silk, Daniel**, Temple Univ. Mail: 2201 Chestnut St., Box 17, Philadelphia, PA 19103 (S)

**Sproul, Edward**, Temple Univ. Mail: 2053 Brandywine Ave., Philadelphia, PA 19130 (S)

**Swank, Robert E.**, Broadcast Techn., PA Public TV Network, Mail: 217 E. High St., Hummelstown, PA 17036 (M)

**Tang, Mark K-W**, Temple Univ., Dept. of Radio-TV-Film, Philadelphia, PA 19122 (S)

**Vaughn, Jr., Lorenzo, D.**, Temple Univ. Mail: 6725 Egret St., Philadelphia, PA 19142 (S)

#### ROCHESTER SECTION

**Andrews, Ronald R.**, Photographic Engr., Eastman Kodak Co., Bldg. 69, Kodak Pk., Rm. 4816, Rochester, NY 14650 (A)

**Brewer, James W.**, Rochester Institute of Technology, Mail: 200 Loden La., Rochester, NY 14623 (S)

**Cuff, Jr., John P.**, Engineering Supvr., WXXI-TV/FM, P.O. Box 21, Rochester, NY 14601 (M)

**Fisher, Norman**, Rochester Institute of Technology, Box 374, 25 Andrews Memorial Dr., Rochester, NY 14623 (S)

**Freedman, Philip M.**, Rochester Institute of Technology, Mail: 25 Andrews Memorial Dr., Box 290, Rochester, NY 14623 (S)

**Harding, Bruce E.**, Cornell Univ., Educational TV Center, MVR Hall, Ithaca, NY 14853 (M)

**Lawrence, Peter A.**, General Mgr., Thornton Theatres Inc. Mail: P.O. Box 115, Saugerties, NY 12477 (A)

**Libero, Robert W.**, Dutchess Community College, Mail: Baldwin Rd., Patterson, NY 12563 (S)

**Mathews, Michael E.**, Tech. Dir., Chautauqua Institution, P.O. Box 1062, Chautauqua, NY 14722 (M)

**Neal, C. Bailey**, Mgr. of Advanced Dev., GTE Sylvania, Inc. Mail: 8062 S. Bennett Hts., Batavia, NY 14020 (M)

**Pier, David J.**, Lighting Dir., Ice Follies, Mail: 308 E. Main St., Hartwick, NY 13348 (A)

**Priester, Wilhna C.**, Product Engr., Eastman Kodak Co. Mail: 212 Windemere Rd., Rochester, NY 14610 (M)

**Willis, Arthur P.**, Technical Editor, Eastman Co. Mail: 471 Winona Blvd., Rochester, NY 14617 (M)

#### ROCKY MOUNTAIN SECTION

**Atkins, J. Gary**, District Mgr., RIA Corp., 430 Garland, Lakewood, CO 80226 (M)

**Brungardt, Michael J.**, Field Rep., Cinema Service Inc. Mail: 525 E. Platte St., Colorado Springs, CO 80903 (A)

**Campbell, Ross S.**, Montana State Univ. Mail: Rt. 4, 80 Gareth Way, Bozeman, MT 59715 (S)

**Freier, Robert**, Projectionist & Equip. Maint., Cinema Arts Corp. Mail: P.O. Box 851, Craig, CO 81625 (A)

**Hatch, Robert N.**, Brigham Young Univ., 356 W. 200 North, Provo, UT 84601 (S)

**Heil, Roger A.**, Customer Service, Western Cine Service, Mail: 2240 Billings St., Aurora, CO 80011 (A)

**More, Larry A.**, Electronic Spec. C., Colorado State Univ. Mail: 101 S. Taft Hill Rd., Ft. Collins, CO 80521 (M)

**Morefield, Robert**, Electronics Splst., Colorado State Univ. Mail: 2613 Stanford Rd., #20A, Ft. Collins, CO 80521 (A)

**Murray, Michael R.**, Mgr., Video Systems Div., Davis Audio-Visual, Mail: 42 S. Holman Way, #41, Golden, CO 80401 (M)

# Reliable, versatile, cost-effective, and it's state-of-the-art.

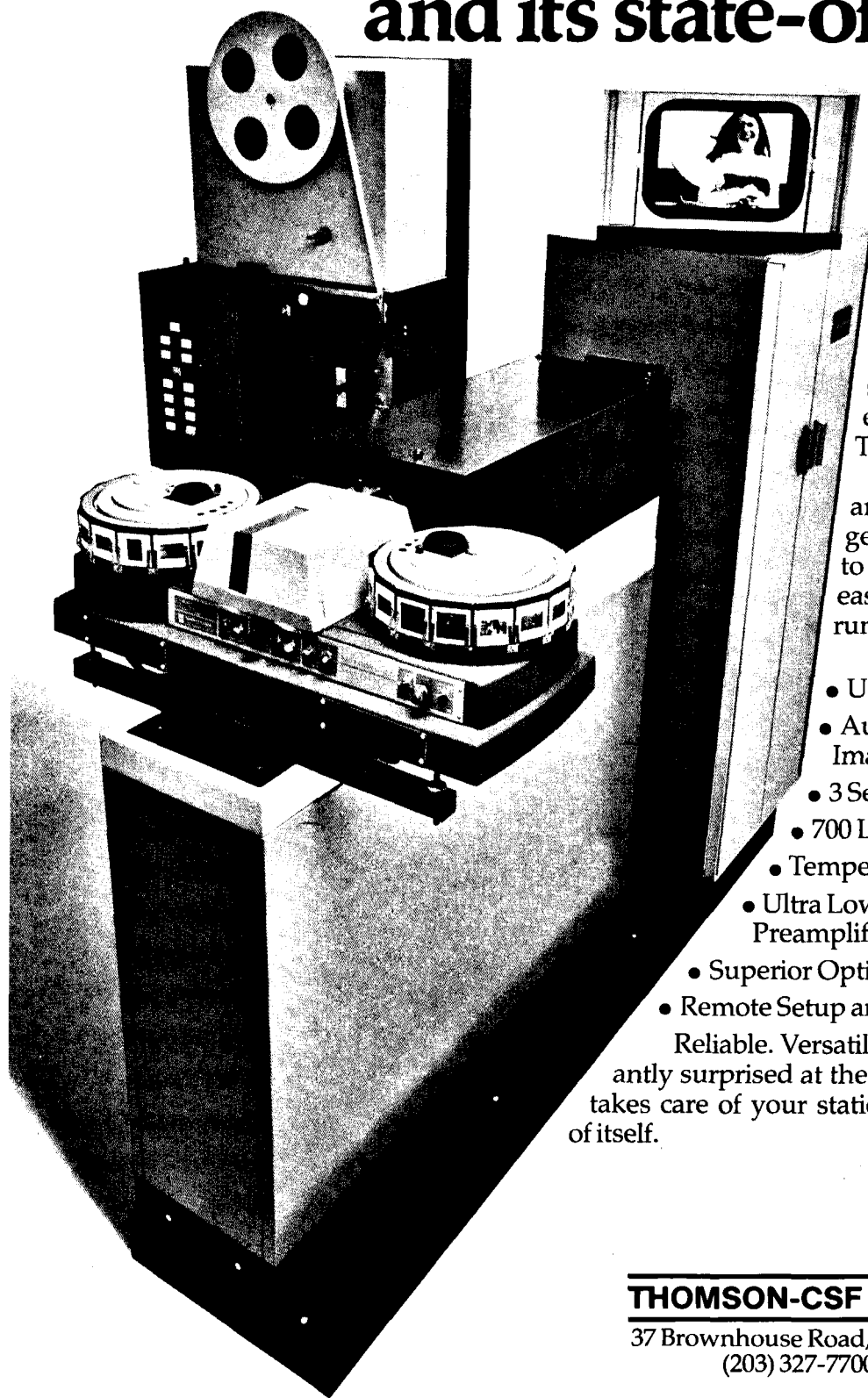

That's the Thomson-CSF Laboratories 1550 Telecine System. A heavy-duty, multi-duty system designed to handle the everyday demands of your TV station.

Built to be self-monitoring and self-regulating, with a rugged, ultrastable electronic design to insure reliable performance and easy maintenance. It practically runs itself.

Check these features:

- Unsurpassed Colorimetry.
- Automatic Color Balance and Image Enhancement.
- 3 Separate Mesh Vidicons.
- 700 Line Resolution, 600 Line Corner.
- Temperature-Compensated Amplifiers.
- Ultra Low Noise Level FET Video Preamplifiers.
- Superior Optical System.
- Remote Setup and Control Panels.

Reliable. Versatile. Cost-effective. You'll be pleasantly surprised at the price. The 1550 Telecine System takes care of your station, while practically taking care of itself.



## **THOMSON-CSF LABORATORIES, INC.**

37 Brownhouse Road, Stamford, Connecticut 06902  
(203) 327-7700/TWX (710) 474-3346

For further information contact:

Northeast Office: 37 Brownhouse Road, Stamford, Connecticut 06902 • Telephone (203) 327-7700  
Southeast Office: 37 Brownhouse Road, Stamford, Connecticut 06902 • Telephone (203) 327-7700  
Midwestern Office: 4220H Casa Brazilia Drive, St. Louis, Missouri 63129 • Telephone (314) 487-2450  
Western Office: Post Office Box 36, La Canada, California 91011 • Telephone (213) 790-4393  
Thomson — CSF Canada Ltd., 1000 Sherbrooke Street West, Montreal, Quebec H3A2P3 • Telephone (514) 288-4148

# SAVE THOUSANDS\$\$\$



## WITH OUR CP-16 TRADE-UP '77 SPECIAL!

### Trade-in any 16mm camera...

Our CP-16 Trade-Up '77 offer is a unique opportunity for all television stations, freelance news/documentary cameramen and young independent filmmakers to trade up to the most popular 16mm newsfilm/documentary camera of the 1970's!

PURCHASE:	CP-16 (Code #1C216)		CP-16/A (Code #1C272)	
	You Pay Only:	You Save: (off list)	You Pay Only:	You Save: (off list)
	\$3400	\$1000	\$4250	\$1250

lens with Automatic Iris Control (instead of the standard 12-120mm zoom).

### Incredibly low prices.

This is the time to retire any old 16mm camera you presently own — whatever its condition — and trade up to a CP-16 for the incredibly low price of \$3400! Or \$4250 for a CP-16/A with built-in Crystalsound amplifier!

### Save up to \$3455!

Better yet, trade-in any 16mm camera and lens for the most spectacular savings on camera/lens package deals.

For example, a CP-16/A with Angenieux 12-120mm AV30 DA lens with Automatic Iris Control. As an added bonus, we include a front-



### Trade-in any 16mm camera and lens...

PURCHASE:	CP-16 (Code #1C216) with one of the lenses listed below.		CP-16/A (Code #1C272) with one of the lenses listed below.	
	You Pay Only:	You Save: (off list)	You Pay Only:	You Save: (off list)
with Angenieux 12-120mm AV30 DA Zoom Lens (Automatic Iris Control)	\$6400	\$3040	\$7250	\$3455
with Angenieux 12-120mm AV30 Zoom Lens	\$6200	\$1540	\$7050	\$1790
with Angenieux 9.5-57mm AV30 Zoom Lens	\$6500	\$1825	\$7350	\$2075

mounted VU meter (Code #1M113) at no extra charge. You save \$3455 off list!

### Automatic Iris Control for only \$200 extra!

Study the chart and pick the package deal that suits you

best. Please note that, for a mere \$200 extra, you can now have a camera/lens package with the Angenieux 12-120mm AV30 DA

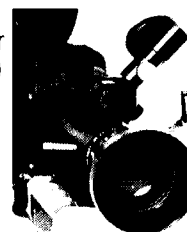

### Trade-Up '77 Warranty

This special offer is covered by an extended two-year factory warranty on all mechanical and electronic components when you purchase your camera from your authorized local CP-16 dealer.

Your local dealer will also provide you with a free CP-16 "loaner" for any down time on a warranty-covered repair.

### Special Magnetic Head Trade-In Offer

Trade in any professional 16mm magnetic head for a 3XL-IAZ magnetic head (with individual record and playback azimuth adjustment) at the special price of \$270!



This SPECIAL OFFER is good 'til JUNE 30, 1977

**cinema E products**  
CORPORATION

Technology In The Service Of Creativity

2037 Granville Avenue, Los Angeles, California 90025  
Telephone: (213) 478-0711 ■ Telex: 69-1339 ■ Cable: Cinedevco

See your local CP-16 Dealer now... and SAVE.

**Parman, Will**, TV Studio Mgr., Hewlett-Packard Co., P.O. Box 301, Denver CO 80537 (M)  
**Proctor, Roger K.**, Electronic Splst., Colorado State Univ. Mail: 1112 Columbine Ct., #1, Fort Collins, CO 80521 (M)  
**Schwartz, Steven J.**, Video Engr., Video Maintenance, The Summit Lighthouse. Mail: 1st & Broadmoor St., Colorado Springs, CO 80906 (A)  
**Smith, Daniel E.**, Electronic Spec., Colorado State Univ. Mail: 805 Timber La., Ft. Collins, CO 80521 (M)  
**Webb, Richard C.**, Pres., Webb Engineering Co., 4906 Club House Court, Boulder, CO 80301 (A)

### SAN FRANCISCO SECTION

**Cochran, Donald J.**, Project/Mktg. Management, Merlin Engineering Works, Inc. Mail: 2012 King's Ln., San Mateo, CA 94402 (M)  
**Coryell, Daniel C.**, T. D. Broadcasting Services, Patten Bible College. Mail: 3241 Davis St., Oakland, CA 94601 (A)  
**Deal, John V.**, Pres., Alta California Systems, Inc., 3000 Sand Hill Rd., Menlo Park, CA 94025 (A)  
**Diermann, Joachim P.**, Chf. Engr., Audio Video Systems Div., Ampex Corp. Mail: 3440 Kenneth Dr., Palo Alto, CA 94303 (M)  
**Harrison, Ron**, Staff Engr., Consolidated Video Systems. Mail: 2924 Cortina Dr., San Jose, CA 95132 (M)  
**Hutchins, James A.**, City College of San Francisco. Mail: 1045 Mason St., #1, San Francisco, CA 94108 (S)  
**Kipping, Vern**, FBI. Mail: 540 Melrose Ave., San Francisco, CA 94127 (A)  
**Lederer, Howard**, Lederer Laboratory, 5239 Lodato Ct., Concord, CA 94521 (M)  
**Mayer, James P.**, Communications Splst., Xerox. Mail: 4195 26 St., San Francisco, CA 94131 (M)  
**McDermott, Timothy J.**, Philip A. Hunt Chemical Corp., 725 Army St., San Francisco, CA 94124 (A)  
**Meker, Lothar H.**, TV Engrg. Supvr., Far East Network, FEN Box 30246, APO San Francisco, CA 96239 (A)  
**Paz, Alberto B.**, Product Mgr., International Video Corp. Mail: 1009 Amadore Ave., Sunnyvale, CA 94086 (A)  
**Peterson, Joseph J.**, Video Prodn. Engr., Measurex. Mail: 1667 Kamsack, Sunnyvale, CA 94087 (M)  
**Queller, Herbert**, Naval Regional Med. Cent., Div. of A/V Medical Education. Mail: c/o Smith, 6141 Hillmont Ave., Oakland, CA 94605 (M)  
**Rolin, James K.**, Videotape Editor, Television Associates, Inc. Mail: 2260 S. Court, Palo Alto, CA 94301 (A)  
**Seabolt, Gerald D.**, Electrical Engr., International Video Corp. Mail: 1097 Thorndale Ct., San Jose, CA 95121 (M)  
**Shoup, Richard G.**, Scientist, Xerox Research, 3333 Coyote Hill Rd., Palo Alto, CA 94304 (M)  
**Vodicka, Milan**, Engr., Ampex Corp. Mail: 402 Roosevelt Ave., Redwood City, CA 94061 (M)

### TORONTO SECTION

**Barr, Joe**, Res. Officer, O.I.S.E., 252 Bloor St., W., Toronto, Ont., Canada M5S 1V6 (A)  
**Bolduc, Norman**, Humber College of Applied Arts & Tech. Mail: 19 Harlow Cres., Rexdale, Ont., Canada M9V 2Y6 (S)  
**Cheng, Allen**, Ryerson Polytechnical Institute. Mail: 96 Gerrard St., East, Apt. 12-B3, Toronto, Ont., Canada M5B 1G7 (S)  
**Colquhoun, Ian**, Techn. (Electronics), Braun Electric Canada Ltd. Mail: 1901 Martingrove Rd., Apt. 307, Rexdale, Ont., Canada M9V 3T1 (A)  
**Cone, Michael A.**, Dir. of Photography, MacVish Commission Photographers, 50 Stephanie St., #812, Toronto, Ont., Canada M5T 1B3 (M)  
**Critchley, Arthur W.**, Sr. Video Designer, Richmond Hill Laboratories Ltd. Mail: 6 Abercorn Rd., Markham, Ont., Canada L3P 1V3 (M)  
**Czudjowycz, Nick**, Conestoga College. Mail: P.O. Box 715, Waterloo, Ont., Canada N2J 4R8 (S)

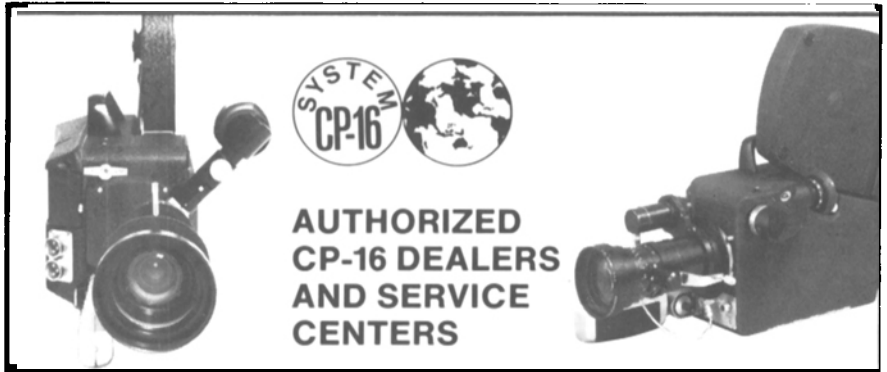

### NORTH AMERICAN LISTING/EFFECTIVE: NOVEMBER 15, 1976

(D/S) Dealer & Service (D) Dealer (S) Service

<p><b>ALABAMA</b>            Bush &amp; Millimaki Photo Equipment Service            902 Bob Wallace Ave. Huntsville, Ala. 35801 (D/S)</p> <p><b>CALIFORNIA</b>            Alan Gordon Enterprises, Inc.            1430 N. Cahuenga Blvd. Hollywood, Ca. 90028 (D/S)            Birns &amp; Sawyer, Inc.            1026 No. Highland Ave. Hollywood, Ca. 90038 (D/S)            F&amp;B/Ceco Of California, Inc.            7051 Santa Monica Blvd. Hollywood, Ca. 90038 (D/S)            Lloyd's Camera Exchange, Inc.            1612 N. Cahuenga Blvd. Hollywood, Ca. 90028 (D/S)            Jack Pili &amp; Associates            6370 Santa Monica Blvd. Hollywood, Ca. 90038 (D/S)            Sawyer Camera Co.            6820 Santa Monica Blvd. Hollywood, Ca. 90038 (D/S)            Camera World            1071 Sixth Ave. San Diego, Ca. 92101 (S)            Adolph Gesser, Inc.            181 Second St. San Francisco, Ca. 94105 (D/S)            Film Equipment Rental Co.            363 Brannan St. San Francisco, Ca. 94107 (D/S)</p> <p><b>COLORADO</b>            Film Equipment Service Company            1113 S. Pearl St. Denver, Co. 80210 (S)</p> <p><b>CONNECTICUT</b>            Cinelease, Inc.            209B Old Durham Road Killingsworth, Conn. 06417 (D/S)</p> <p><b>DISTRICT OF COLUMBIA</b>            Brenner Cine-Sound            5215 Wisconsin Ave., N.W. Washington, D.C. 20015 (D/S)</p> <p><b>FLORIDA</b>            Photomart            6327 S. Orange Ave. Orlando, Fla. 32809 (D/S)</p>	<p><b>HAWAII</b>            Pacific Instrumentation            5388 Papai Street Honolulu, Hawaii 96821 (D/S)</p> <p><b>IDAHO</b>            Stockdale Corporation            1448 W. Bannock Boise, Idaho 83701 (D/S)</p> <p><b>ILLINOIS</b>            Victor Duncan, Inc.            200 E. Ontario St. Chicago, Ill. 60611 (D/S)</p> <p><b>LOUISIANA</b>            La Del, Inc.            808 N. Rampart St. New Orleans, La. 70116 (D/S)</p> <p><b>MASSACHUSETTS</b>            Crimson Camera Technical Sales, Inc.            60 Landsdowne Cambridge, Mass. 02139 (D/S)            Sanford Camera &amp; Projector Repairs            1054 Massachusetts Ave. Arlington, Mass. 02174 (S)</p> <p><b>MICHIGAN</b>            Victor Duncan, Inc.            11043 Gratiot Ave. Detroit, Mich. 48213 (D/S)</p> <p><b>MINNESOTA</b>            Maritz Laboratories, Inc.            3000 France Ave. Minneapolis, Minn. 55416 (D/S)</p> <p><b>MISSOURI</b>            Calvin Cinequip, Inc.            215 W. Pershing Road Kansas City, Mo. 64108 (D/S)</p> <p><b>NEW JERSEY</b>            Cinecraft International, Inc.            11 Caesar Place Moonachie, N.J. 07074 (D/S)</p> <p><b>NEW YORK</b>            Camera Mart, Inc.            456 W. 55th St. New York, N.Y. 10019 (D/S)            F&amp;B/Ceco, Inc.            315 West 43rd St. New York, N.Y. 10036 (D/S)            Film Equipment Rental Co.            419 West 54th St. New York, N.Y. 10019 (D/S)            Mobius Cine Ltd.            7 East 47th St. New York, N.Y. 10017 (D/S)</p>	<p><b>NORTH CAROLINA</b>            Standard Theatre Supply Co.            125 Higgins St. Greensboro, N.C. 27420 (D/S)</p> <p><b>OREGON</b>            Things Unlimited            3140 N.E. Bryce Portland, Oregon 97212 (S)</p> <p><b>PENNSYLVANIA</b>            Calvin Cinequip, Inc.            217 Vine St. Philadelphia, Penn. 19106 (D/S)            Oscar H. Hirt, Inc.            41 N. Eleventh St. Philadelphia, Penn. 19107 (D/S)</p> <p><b>TEXAS</b>            Victor Duncan, Inc.            2659 Fondren Dr. Dallas, Texas 75206 (D/S)            Gordon Yoder, Inc.            2911 Ladybird Lane Dallas, Texas 75220 (D/S)</p> <p><b>UTAH</b>            Stockdale Corporation            2211 N.E. 2300 South Salt Lake City, Utah 84119 (D/S)</p> <p><b>WASHINGTON</b>            Glazer's Camera Supply            1923 Third Ave. Seattle, Washington 98101 (D)            Phototronics            223 West Lake North Seattle, Washington 98109 (S)</p> <p><b>CANADA</b>            Cine Audio Ltd.            10251 - 106 St. Edmonton, Alberta T5J 1H5 (S)            Alex L. Clark Limited            30 Dorchester Ave. Toronto, Ontario M8Z 4W6 (D/S)            Branches:            7104 Hunterwood Rd., N.W. Calgary, Alberta T2K 4J6 (D/S)            1070 Rue Bleury Montreal, Quebec H2Z 1N3 (D/S)            Steve's Camera Service            189 East 28th Ave. Vancouver, B.C. V5V 2M3 (S)            Western Camera Service Ltd.            1855 West Fourth Ave. Vancouver, B.C. V6J 1M4 (S)</p> <p><b>MEXICO</b>            Deksa S.A.            Av. Nuevo Leon No. 159 Mexico 11, D.F. (D/S)</p>
---	---	---

**Cinema E-products CORPORATION**

*Technology in the Service of Creativity*

2037 Granville Avenue, Los Angeles, California 90025  
 Telephone: (213) 478-0711 ■ Telex: 69-1339 ■ Cable: Cinedevco

**Detcher, A. Wayne**, Ryerson Polytechnical Institute. Mail: 1002 Johnathan Dr., Mississauga, Ont., Canada L4Y 1K1 (A)

**Goodall, F. W.**, Kodak Canada Ltd. Mail: 24 Cobblestone Dr., Thornhill, Ont., Canada L3T 4E4 (M)

**Goodwin, H. Earle**, Audio Techn., Ontario Institute for Studies in Edu. Mail: 2063 Islington Ave. #503, Weston, Ont., Canada M9P 2R7 (A)

**Harrison, Martin**, Humber College of Applied Arts & Tech. Mail: 4 Albertus Ave. #4B, Toronto, Ont., Canada M4R 1J4 (S)

**Howard, John A.**, Operations Techn., Ontario Edu. Communications Authority. Mail: 50 Ruddington Dr., Apt. 713, Willowdale, Ont., Canada M2K 2J8 (A)

**Morris, Barbara R.**, Ryerson Polytechnical Institute. Mail: 40 Dartnell Ave., Toronto, Ont., Canada M5R 3A4 (S)

**Pecolt, Edward**, Chf. Engr., CJRT-FM, Ryerson Polytechnical Institute. Mail: 24 Norway Ave., Toronto, Ont., Canada M4L 1P8 (A)

**Phipps, Jay L.**, Coordinator, Media Centre, Ryerson Polytechnical Institute. Mail: 48 Merrylynn Dr., Richmond Hill, Ont., Canada L4C 5A9 (A)

**Seaton, Graham**, Chf. Film Librarian, CTV TV Network, CTV News Film Library, 42 Charles St., E., Toronto, Ont., Canada (A)

**Shen, Sudy**, Chf. of Systems Engr., McCurdy Radio Industries Ltd. Mail: 1200 York Mills Rd., Apt. 1601, Don Mills, Ont., Canada M3A 1X9 (A)

**Shutsa, Jim**, Dir. of News, CITY-TV. Mail: 77 Ryerson Ave., Apt. 507, Toronto, Ont., Canada M5T 2V4 (A)

**Smith, Clive A.**, Product Mgr., Racal-Zonal Magnetics Ltd. Mail: 298 Keewatin Ave., Toronto, Ont., Canada M4P 2A5 (A)

**Squires, Robin**, Engr. Supvr., Electro & Optical Systems Ltd. Mail: 100-57 Burrows Hall Blvd., Agincourt, Ont., Canada M1B 1M7 (A)

**Tomkins, H. E. Sid**, Program Coordinator, Radio-TV Broadcasting, Canadore College. Mail: RR #3, North Bay, Ont., Canada P1B 8G4 (M)

**Woo, Ken K.**, Audio Technologist, Ryerson Polytechnical Institute. Mail: 141 Berkeley St., Toronto, Ont., Canada M5A 2X1 (A)

## WASHINGTON D.C. SECTION

**Dumbeck, Walter J.**, Scientific/Techn. Photographer, Naval Ship R & D Center. Mail: 708 Belfort St., Sterling Park, VA 22170 (M)

**Finley, Otis E., Jr.**, District Sales Mgr., Eastman Kodak Co., 500 12 St., SW, Washington, DC 20024 (M)

**Friedel, Richard**, TV Engr., Univ. of Maryland. Mail: 11016 New Hampshire Ave., Silver Spring, MD 20904 (A)

**Gates, Robert F.**, Engr., Omnificent Systems, 1117 Virginia St., E., Charleston, WV 25301 (A)

**Glass, Jeffrey**, Montgomery College. Mail: 11727 Stonington Pl., Silver Spring, MD 20902 (S)

**Grabarsky, Elchanan**, Chf. Engr., George Washington Univ. Mail: 2416 Ross Rd., Silver Spring, MD 20910 (M)

**Harper, Eric L.**, Mgr., Customer Service, Byron Motion Pictures, 65 K St., N.E., Washington, DC 20002 (A)

**Jones, Hazel H.**, Inspector-Printer, Library of Congress. Mail: 2553 36 St., SE, Washington, DC 20020 (A)

**Jones, Leonard S.**, TV Engr. Supvr., WETA-TV. Mail: 7804 Beechnut Rd., District Heights, MD 20027 (M)

**Kent, Fredrick R.**, Asst. Chf. Engr., WETA-TV. Mail: 3211 Hallran Rd., Falls Church, VA 22041 (M)

**King, Gregory L.**, Video Engr., WETA-TV. Mail: 3103 Good Hope Ave., #413, Hillcrest Heights, MD 20031 (M)

**Lehoucq, Georges**, Plant Engr., Capital Film Laboratories, Inc. Mail: 9436 Goshen La., Burke, VA 22015 (M)

**Maylett, William F.**, Tech. Dir., WETA-TV. Mail: 4747 Kandel Ct., Annandale, VA 22003 (M)

**McCarthy, John T.**, Supvr., A/V Products, U.S. Postal Service. Mail: 9509 Pamplona Rd., Columbia, MD 21045 (M)

**McMurry, Gregory L.**, Chf. Engr., University of Maryland. Mail: 5002 Eutaw Pl., College Park, MD 20740 (A)

**Minicucci, John R.**, Pres., S.E.R.A. Inc., Unit 22-Atrium Bldg., 11250 Roger Bacon Dr., Reston, VA 22090 (A)

**Oakley, Vern**, Georgetown Univ. Mail: 3211 Adams Mill Rd., NW, Washington, DC 20010 (S)

**Seabrook, William R.**, Maint. Supvr., WETA-TV. Mail: Rt. 1, Box 454, Dunkirk, MD 20754 (M)

**Shlyen, Sanford D.**, Tech. Services Engr., Data-Design Laboratories. Mail: 2110 Criston Dr., Newport News, VA 23602 (A)

**Shon, Robert F.**, CCTV Engr., Techn., Model Secondary Sch. for the Deaf. Mail: 7212 Millercrest Ter., Derwood, MD 20855 (M)

**Tyson, Bruce**, Sales Rep., Byron Motion Pictures, 65 K St., NE, Washington, DC 20002 (A)

**Young, Sr, William C.**, A/V Prodn. Splst., TV Studio Mgr., H.E.W., F.D.A., O.P.C.P. Mail: 936 December Court, Gambrills, MD 21054 (M)

## MEMBERS NOT IN SECTION

**Abou-Hammoud, Farah**, MP & AV Supvr., Kodak. Mail: Karpathou-Parou 20, Kifissia, Athens, Greece (A)

**Aggarwal, Vijay G.**, Lab-in-charge & Tech. Supvr., National Film Laboratory. Mail: A/1 Ferreira Madison, Sitladevi Temple Rd., Mahim, Bombay, Maharashtra, India 400 016 (A)

**Ball, Alan E.**, C.C.T.V. Techn., Hampshire Police Authority. Mail: 18 Wilton Dr., Horndean, Portsmouth, Hampshire, England P08 9QY (A)

**Ballard, Leonard E.**, Project Mgr., Eischbach and Moore. Mail: 443 West Ave., Ferndale, Randburg, TVI., South Africa (M)

# Do you need a special purpose lens with a minimum production run?

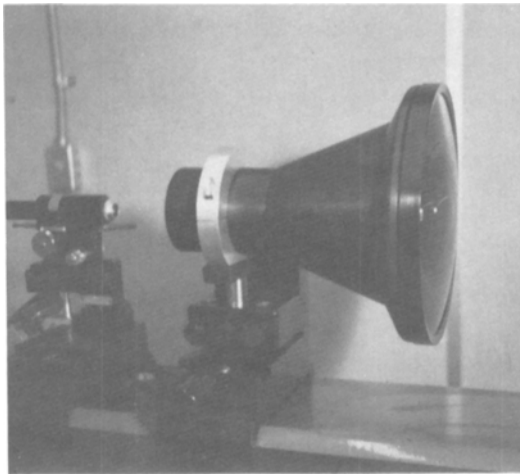

*This is a 160 degree F/2 projection lens for 70mm film. Production run 18 units.*

We are organized to design and fabricate special purpose lenses and if required, limited production runs.

Our services include:

- a) Complete drawing package
- b) Fabrication, assembly of prototype

For nearly 10 years we have done a wide range of work in optics...including Zoom Lenses, Periscope Systems, Camera Lenses and Underwater Optics. Call today or write detailing your particular problem.

## LAIKIN OPTICAL CORP.

5630 Arbor Vitae Street, Los Angeles, CA 90045  
(213) 640-0470

# Meet Terry Zilm, customer service

Terry joined Houston Photo Products 16 years ago and thru the years has contributed much to the company's reputation for fine equipment and reliable service.

A technical problem, a complete installation, a call for spares — from any customer, anywhere, anytime, receives full attention from Terry.

Spare parts for all Houston processors (interchange-

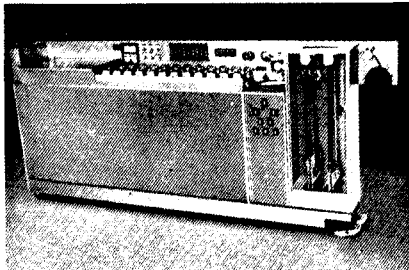

*There's a Houston continuous processor for every type and size of film.*

able for most other machines) are as close as your telephone. Contact our Customer Service. Houston Photo Products, Inc., 655 E. 20th St., Yuma, Ariz. 85364.

Phone: (602) 782-3677.  
European Sales & Service: Jos DeJonghe, 8500 Kortrijk, Belgium. Phone: 56/2117.10. Telex: 85.185.

**HOUSTON**  
PHOTO PRODUCTS, INC.  
YUMA, ARIZONA

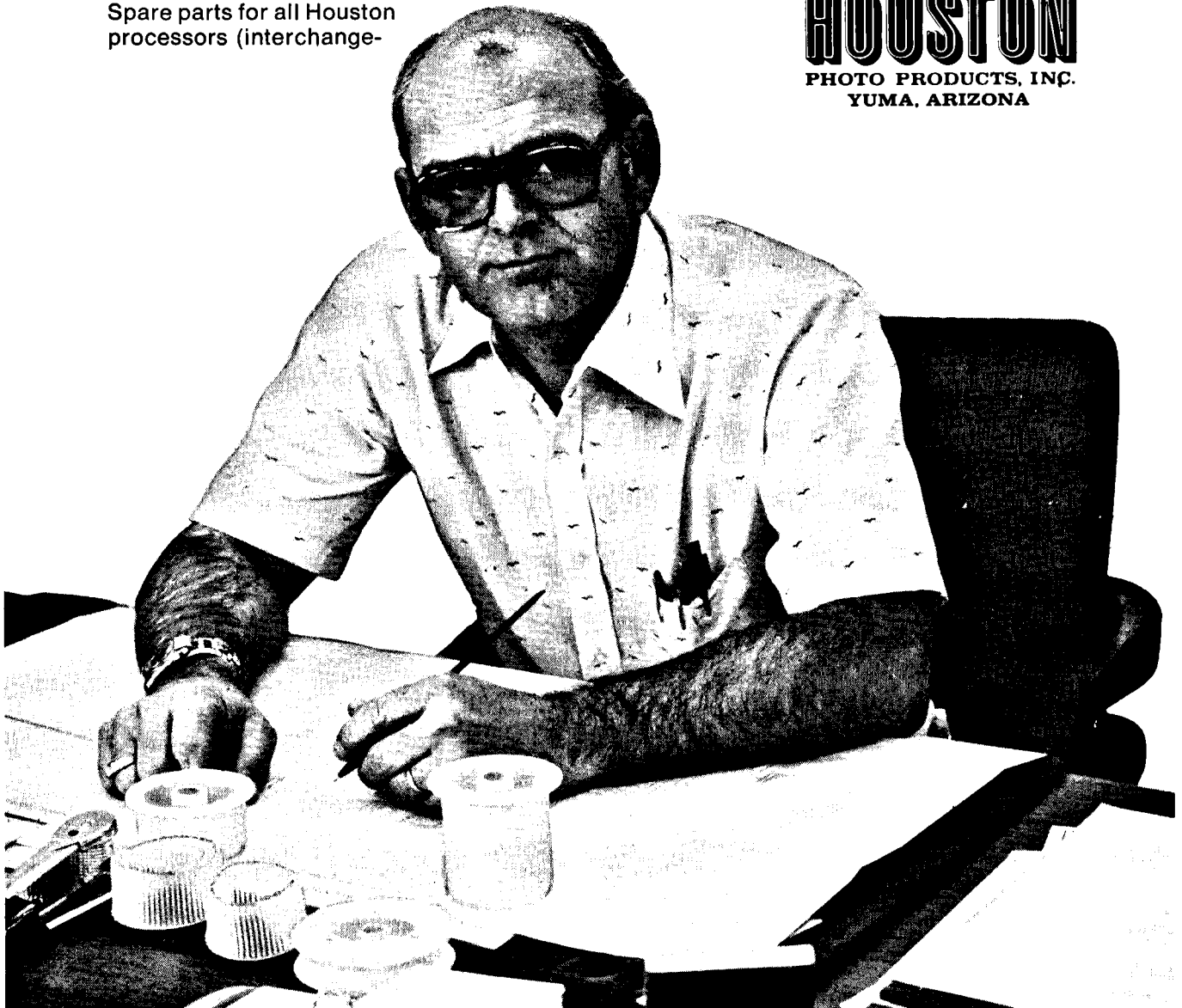

**Bellini, Guglielmo**, Mgr., Filmecchimica S.R.L., Via Tuscolana 1490/A, Rome, Italy (A)

**Binggeli, Pierre**, 67 route de Mategnin, 1217 Meyrin, Switzerland (A)

**Bogwu, Christopher E.**, Asst. TV Engr., University College Hospital, Medical Illustration Unit, Ibadan, Nigeria (A)

**Bramham, Stephen K.**, Pres., Pacific Media Consultants, 1001 Dillingham Blvd., Suite 207A, Honolulu, HI 96817 (A)

**Brantner, Friedrich**, Sound Techn., Wien-Film GmbH, Mail: Koflergasse 4/10, Vienna, Austria A1120 (A)

**Brittschneider, Bernd**, Mgr., Prods. Services & Product Planning MP Mkts., Kodak AG, Mail: In der Reute 5, 7302 Ostfildern 1, Germany (M)

**Brittenden, Robert E. G.**, Science Techn., Dept. Scientific & Industrial Research, Mail: 41 Gresford St., Christchurch 1, New Zealand (A)

**Camargo C., Gabriel**, Apartado Aereo 12351, Bogota, Colombia S.A. (A)

**Carletti Antonio**, Mot. Pic. Supvr., Kodak S.p.A. Italy, Mail: Via del Seminario, 106, Rome, Italy (A)

**Carvajal, Jorge P.**, Engr., Televisora de Occidente, S.A., Av. Alemania Num. 1469, Guadalajara, Jal. Mexico (A)

**Casino, Pedrito E.**, Sr. Film Editor, Bu. of Broadcasts-DPI, Mail: P.O. Box 1672, Manila 2800 Philippines (A)

**Center, Les**, Producer/Dir., Cine Productions, Inc., P.O. Box 241, Devonshire 4, Bermuda (A)

**Chang, Tung K.**, Dir., Flick Pro E Lab De Cinema, Caixa Postal 30821, Sao Paulo, Brasil (M)

**Chee-Yan, Lawrence Chan**, Sls. Mgr., Swire & MacLaine (F.E.) Ltd., 2032 Union House, 9 Connaught Rd. C, Hong Kong (A)

**Chow, Po-Kwong**, Sales Engr., The Radio People, Ltd. Mail: Flat H, Avon Ct., 3 fl., Fessenden Rd., Kowloon Tong, Kowloon, Hong Kong (A)

**Chung, Choon-Ki**, Techn., Maintenance Dept., Kore-

an Film Unit, #1 Sejong-Ro., Seoul 110, Korea (A)

**Doncov, Boris**, Technical Mgr., Sony Service Centre (Europe) N.V., Halfstraat 80, 2621 Schelle (Antwerp) Belgium (M)

**Du Pleissis, Pieter G.**, 35mm Workshop Mgr., ACF Merchandise, Mail: P.O. Box 2136, Rensburg, TV1., South Africa 2401 (A)

**Eaton, Wayne H.**, Field Service Engr., Ampex Europa GmbH, Mail: Starckenburgring 29, 6057 Dietzenbach, West Germany (A)

**Ebbetts, Roland F.**, Managing Dir., Cringleford, Cherrytree La., Chalfond St. Peter, Buck., England (M)

**Erixon, Mats**, Royal Institute of Technology, Mail: Bastugatan 1 A, 1/2 tr., S-117 20 Stockholm, Sweden (S)

**Esan, Gabriel O.**, Sr. Techn., Univ. of Ibadan, Maintenance Dept., Telecom Section, Ibadan, Nigeria (A)

**Eu, John K. D.**, Euco Perniagaan Sdn. Bhd., P.O. Box 353, 159 Jalan Birch, Kuala Lumpur 08-02, Malaysia (A)

**Folie, Andre**, Technical Engr. Mail: Rue du Zodi-ique 21, B 1180 Brussels, Belgium (A)

**Gaitan, Tomas**, Mgr., Foto Miza S.A., Londres 75-501, Mexico City, Mexico 6 DF (A)

**Gooes, Roland**, Dir., AB Hollywood Filmlaboratorium, Staffansvagen 27, S 191 78 Sollentuna, Sweden (A)

**Harrikyisna, Anenden**, London Int. Film School, Mail: 146 Corbyn St., London N 4, England (S)

**Hong, Seong-Bim**, Lab. Dept., Korean Film Unit, #1 Sejong-Ro., Seoul 110, Korea (A)

**Iniekung, Eta**, Asst. TV Engr., University College Hospital, Medical Library, Ibadan, Nigeria (A)

**Iqbal, Jawaid**, Chemist, Ashraf & Co., MP/AV Div., P.O. Box 3555, Kuwait, Kuwait (A)

**Jonsson, Erik**, Sr. Engr., Philips Elektronikindustrier, Mail: Klovrvagen 12, Jarfalla, Sweden S17543 (A)

**Keller, P.**, Export Sls. Mgr., Kodak (South Africa) Pty Ltd. Mail: No. 5 Howglen Villa, 30 Albert Rd., Tamboerskloof, Rep. of S. Africa 8001 (A)

**Kong, Peter**, Tech. Sales Rep., Kodak (Far East) Ltd., 321 Java Rd., North Point, Hong Kong (A)

**Koyabu, Kazuo**, Dir., Noritsu Koki Co. Ltd., 499-6 Nakajima, Wakayama, Japan 641 (A)

**Lam, Kenneth, Chun-Kau**, Mgr., International Video Corp., 8A Granville Rd., 1101 Prosperity House, Kowloon, Hong Kong (A)

**Lee, Ho-Young**, Lab. Dept., Korean Film Unit, 1 Sejong-Ro, Seoul 110, Korea (A)

**Lee, James T.**, Pres., Asia Electric Trading Co. Mail: 55 Min Chuan W. Rd., 3 fl., Taipei, Taiwan, R.O.C. (M)

**Lee, Nak-Hii**, Chf. of Lab., Korean Film Unit, #1 Sejong-Ro, Shango-Ku, Seoul 110, Korea (A)

**Li, Henry Hong-Yan**, Sales Rep., Kodak (Far East) Ltd., 321 Java Rd., North Point, Hong Kong (A)

**Maeda, Mutsuo**, Dir., Market Dev. Kodak (Far East) Ltd., c/o Nagase & Co. Ltd., No 3 Kobuna-cho Z-chome, Nihonbashi, Chuo-Ku, Tokyo, Japan (A)

**Marti, Bernard**, Chf. Engr., CCETT, Mail: La Piece Echevliere-Les Motais, Noyal s/ Vilaine, France 35530 (M)

**Maurizio, Gennaro**, Dir. of Photography, Mail: via P. Venturi 6, 00149 Roma, Italy (A)

**Mehta, Hector**, Chairman, Modern Sixteen Cine Lab. Pvt. L., Sahas, 414/2 Vir Sawaricar Rd., Bombay 400 020 India (A)

**Morizono, Masahiko**, Dir., Sony Corp., 6-7-35 Kitashinagawa, Shinagawa-Ku, Tokyo, Japan (M)

**Mutakyamirwa, Charles S.**, Asst. Engr., Tanzania Film Co., P.O. Box 9341, Daressalaam, Tanzania (A)

**Nadiadwala, A. A.**, Managing Dir., A. G. Films Private Ltd., Lotia Palace, 373 Linking Rd., Khar, Bombay 4000052, India (A)

## LASER CHROME FILM RECORDER

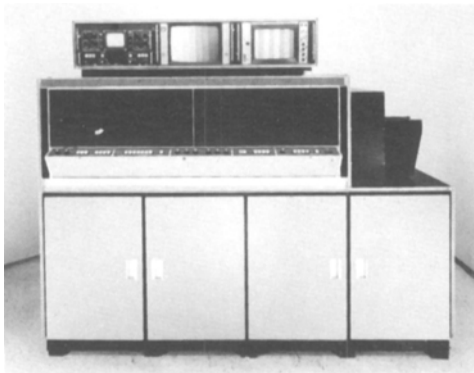

### FEATURES

- High Resolution
- Real Time Recording
- High Color Purity
- Precise Color Registration
- No Phosphor Decay Effect
- Excellent Scan Linearity

**DESCRIPTION:** The Laser Chrome Film Recorder is a tape-to-film transfer system that accepts a standard television signal and uses laser technology to create an intense, high-resolution color image for directly exposing film in a fast pulldown film camera (not included).

**DELIVERY:** The last unit built by CBS Laboratories is available. Two units (PAL and NTSC) are located at Rank Video Centre, London, England (see "The Year of Laser Scan" by Rank's ADL Jackson in International Broadcast Engineer, April-May 1976). Flexible terms will be negotiated.

**DIRECT INQUIRIES TO:** CBS Technology Center / 227 High Ridge Road / Stamford, Connecticut 06905 / Tel: (203) 327-2000

1973

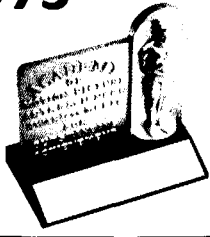

# How do you improve on an Academy Award? ..... With innovative research and development.

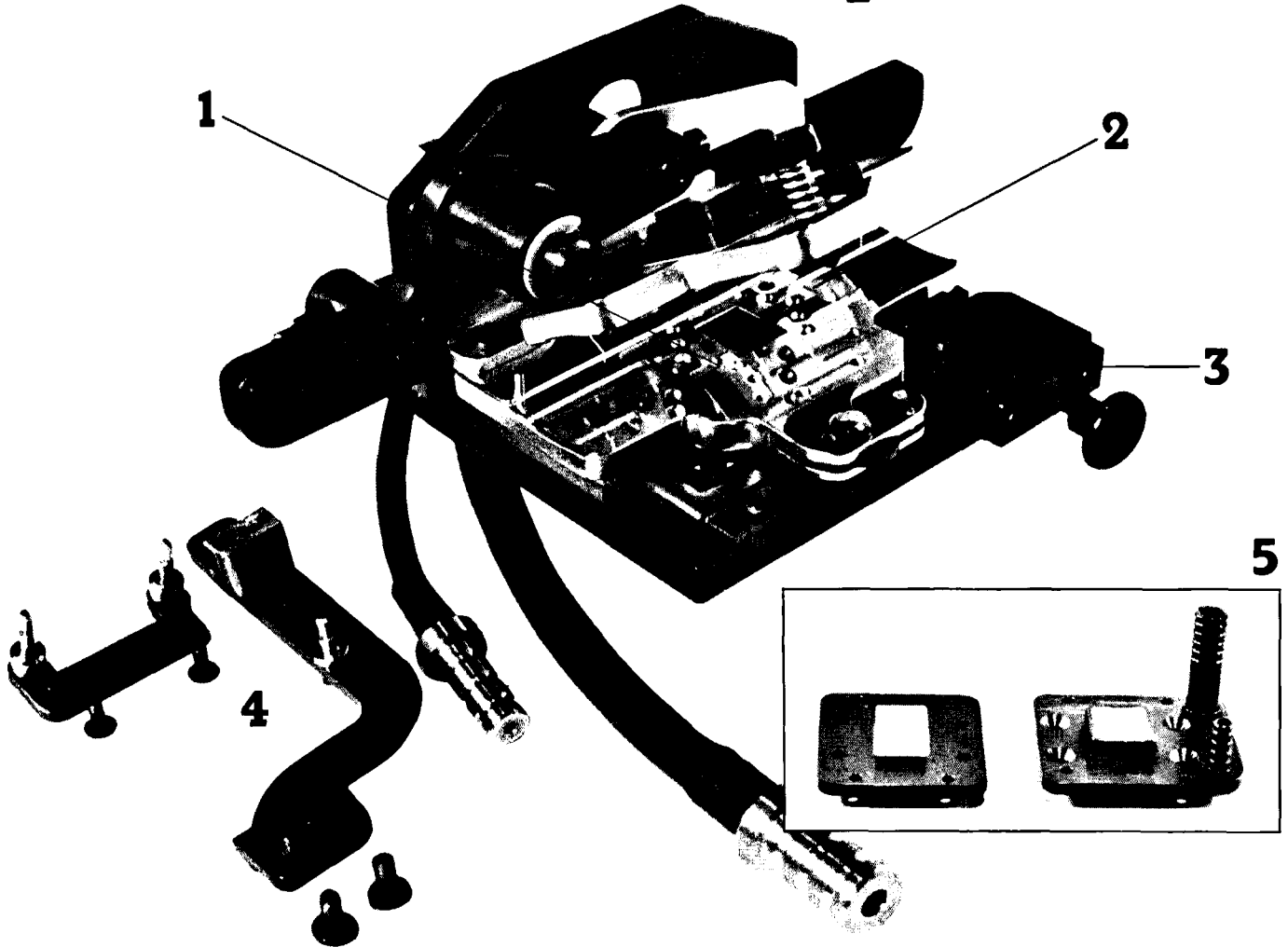

**OXBERRY's** research and development never stopped! We began the era of the commercial liquid gate and have since maintained world-wide leadership with 35mm, 16mm, S-8 and custom sized liquid gates for all major optical printers. We are now proud to introduce our "second generation" 16mm liquid gate incorporating many vital new improvements and features:

- 1. improved the stability of the fixed pin registration by bringing the pin closer to the aperture. This is now the same as the dry gates, but one perforation away from the aperture.
- 2. improving the liquid flow pattern allowing the liquid to come out from around the glass windows. This permits increasing the distance between the film and the glass reducing the danger of scratches and dirt on the glass as well as making the pressure and vacuum settings less critical.

3. improved accessibility for maintenance and cleaning by making the gate open to 45°.

4. added the option of interchangeable pins that can be moved from the inside to the outside perforations by removing four screws. This allows the shooting of A&B rolls without the need to shoot from "tails" and also the printing of film with damaged perforations on one side.

5. added the option of replacing the liquid gate windows in the field. This eliminates the need for factory replacement.

**The gate and it's improvements are at the same old price.** For more information on OXBERRY liquid gates and other OXBERRY products write:



Division of Richmark Camera Service  
516 Timpson Place, Bronx, N.Y. 10455  
Tel. (212) 585-0730 Cable Oxberry, N.Y.  
Telex No. 422250 RCS

# WESTERN



## Cine

the right  
place for  
all your  
lab work!

EASTMAN COLOR  
INTER-NEGATIVE  
and POSITIVE  
16mm & 35mm

PROCESSING  
ECN II, ECO, EF, CRI  
16mm & 35mm

FULL IMMERSION  
WET GATE  
PRINTING

- Video Analyzing
- Sound Recording and Mixing
- Optical Printing
- Titling
- Super 8mm Reduction Printing
- Filmstrip

*We are a quality-oriented lab...  
Computerized printing...  
Contact our producers' service  
specialists...  
We do the job right!*



## WESTERN Cine

DENVER  
312 So. Pearl St. - Denver, Colo. 80209  
Cine Craft  
8764 Beverly Blvd. - Hollywood, Calif. 90048

**Nicolai, Alfredo**, Marketing Mgr., Stacofilm S.p.A.  
Mial: Via Apulia 15, Rome, Italy (A)

**Odikagbue, Emmanuel O.**, Audio-Visual Demonstrator, Univ. of Ibadan, Medical Illustration Unit, Univ. College Hospital, Ibadan, Nigeria W.A. (A)

**Park, Nam-Ki**, Chf. 16mm Lab. Dept., Korean Film Unit, 1 Sejong-Ro., Seoul 110, Korea (A)

**Pessis, Georges**, 52 Avenue des Tilleuls, 75016 Paris, France (A)

**Plummer, Edward**, Prodn. Controller. Mail: 27 A Block, Usha Sadan Colaba Post Office, Bombay, India 400 005 (A)

**Raczkovi, Werner**, Schlossgasse 2a, 1050 Vienna, Austria (M)

**Raposa, Paulo Da Silva**, National Sls. Mgr., Kodak Brasileira Com. Ind. Ltda., Praca George Eastman S/No, Sao Paulo, Brasil SP 05690 (M)

**Rhee, Inheng**, Pres. & Chf. Engr., Mansung Traders Co., C.P.O. Box 395, Seoul, Korea (A)

**Rhee, Kunjong**, Chf. Lab. Engr., 35mm Dept., Korean Film Unit, 1 Sejong-Ro, Seoul 110, Korea (A)

**Rugg, Noel A.**, Managing Dir., Video Tape & Film Services Ltd. Mail: 482 Blockhouse Bay Rd., Auckland 7, New Zealand (M)

**Sambe, John A.**, Lecturer, Univ. of Ibadan, Dept. of Theatre, Ibadan, Nigeria (A)

**Schweizer, Anthony**, Tech. Dir., Schweizer Filmtechnik. Mail: Steinenweg 22, Ch 4431 Lampenberg, Switzerland (M)

**Spataro L. Biagio**, Dir. of T.V. Dept., Univ. Nacional Experimental de Los Llanos. Mail: Av. 34 No. 34-54 Acarigua, Portuguesa, Venezuela (A)

**Sjoman, Per Stephan**, Managing Dir., Cinema Electronics AB, Box 24120, S-400 22 Gothenburg, Sweden (A)

**Sucharov, Algernon**, Camera Asst. Mail: 232 Mueswell Hill Broadway, London N10 1DE, England (A)

**Tada, Shin**, Chf. Cameraman, RKC Kochi Broadcasting Co., Ltd. Mail: 2-14-19 Kaganoi, Kochi City, Japan (M)

**Taylor, H. C.**, Dir. R & D, William F. Rees Ltd., Westminster House, High St., Old Woking, Surrey, England (A)

**Van Tetering, A.M.A.**, Pres., Animex Inc., P.O. Box 6285, Haarlem, Holland (A)

**Woods, Frederick E.**, Service Engr., Rank Leisure Services. Mail: 29 Lorenzo Dr., Liverpool, England L11 1BE (A)

**Yamamoto, Toyotaka**, Professor, Nihon Univ., Dept. of Cinema. Mail: 36-3, 3 chome, Daita, Setagayak-ku, Tokyo, Japan (A)

**Yen, Si Chun**, Studio Engr. Mail: Rm. 1414, Sun Man House, 01 Man Estate, Kowloon, Hong Kong (A)



## Section Meetings

**Detroit, 15 Dec.** — The meeting was held in the video studios of the Michigan Bell Telephone Building in Detroit with an attendance of 27 members and guests. Robert E. Klacza, a design engineer specializing in digital and analog signal processing circuitry, gave a presentation entitled "Automatic Cue Pulse Programmer for Film/Slide Intermittent Projection System." He used 35mm slides and an overhead projector to illustrate his talk.

Herb Quilitzsch of Micro-Consultants demonstrated the Model DFS-3000 frame storer/synchronizer designed to "shrink" the TV picture for insertion. Following the program Fred Edwards of Michigan Bell conducted a tour of the new TV facilities in the Bell Building. — Warren Happel (Secretary-Treasurer). Browne Associates, 25 W. Long Lake Rd., Bloomfield Hills, MI 48013.

**Dallas/Fort Worth, 1 Dec.** — The meeting was held at the Broadcast/Film Arts Studios of Southern Methodist University with an attendance of 43 members and guests. Speakers were James Zinn and Don Pasquella, both Instructors at SMU. Theme of the meeting was SMU Student Film/Tape Expo-76. Zinn opened the program by showing a 28-ft videotape in color concerning man's environmental relationship to animals. A critic's panel selected from SMPT membership for film production — Mel Dunn, Michael Lorfing and Bill Henry and a panel for videotape production — Clyde Miller and Bob Turner rated the production as excellent. (The production has been aired on TV.)

The student production crew was on hand to answer questions on production techniques and

to discuss the problems encountered.

The film, *Car Hop*, was presented by Pasquella. The film was in 16mm color and sync sound with a running time of 15 min. While the film was being shot on location at a local car hop drive-in the owner said he had some Kodachrome footage of his place and the car hops taken about 1950. The film was in excellent condition and the cameraman had done a remarkable job. Much of this footage was used in the final production and offered the audience a humorous retrospect. This is a delightful and entertaining film which was enthusiastically received and applauded by the audience. The critic's panel awarded the production an outstanding rating. — Melvin E. Dunn (Secretary-Treasurer), American Schools of Cinema; home address, 2002 Peters Colony Rd., Carrollton, TX 75006.

**Hollywood, 16 Nov.** — The meeting was held in a screening room at Burbank Studios with an attendance of 150 members and guests. The speakers were David M. Stern of L-W International, Dan Brewer of Burbank Studios, and Richard Hill of Consolidated Film Industries. Stern presented a paper on the Athena 5000 television projector. Using slides he showed the audience many views of the projector showing the different modes of operation. Audience interest was displayed by the number of questions asked following the presentation.

Brewer and Hill described a method of editing a motion picture through the use of videotape by transferring the color dailies to videotape and using computer-assisted videotape editing. In this way several versions can be made without