

New Projection Lenses for 35-mm Cinema Projectors

By KARL MACHER

A new range of projection lenses for 35-mm cinema projectors is described. General requirements for projection lenses are mentioned. Basic design considerations for the new lens — the Cinelux-Ultra lens — are discussed. Its modulation transfer function (MTF) and other parameters (field curvature, light transmission efficiency, field illumination evenness, distortion, lateral chromatic aberration) are illustrated, and some are compared to earlier Schneider projection lens designs.

Requirements for Projection Lenses

In the image forming chain consisting of the object, the camera film image, the print, and the projected picture, there are often three optical systems involved: the camera lens, the copy lens of an optical printer, and in the final step the projector lens. As far as the original film is concerned, the cameraman has a wide range of lenses available to him. The choice of lens or lenses he wishes to use depends entirely on the conditions prevailing when shooting the scene and on the creative talent of the cameraman. Camera lenses vary in relative aperture and focal length, and the most frequently used ones are optical systems with variable focal length (zoom lenses).

Compared to this, the projection lenses as used in cinemas and studio theaters have a very different purpose; they are required to yield a brilliant and clear image over the entire surface of the screen. The choice of focal length depends upon the theater size, that is to say, on the projection throw. Systems with variable focal length are of little value for this purpose, because projection distance and screen size are predetermined and a change of reproduction scale inside the auditorium is usually not necessary.

To satisfy the requirements for different room sizes in cinemas or studio theaters, a series of projection lenses with different progressively stepped focal lengths must be available. The choice of the most suitable focal length for a given projection throw is then determined with the aid of the following simple approximation formula: $f \cong (b \times E)/B$, where f is the required focal length, b is the width of the projector aperture mask, E is the projection distance or throw, and B is the width of the projected screen image.

A new series of projection lenses is now available under the trade name Cinelux-Ultra™. They have a relative aperture of $f/2.0$ and focal lengths which range from 50 to 150 mm in focal length steps of

The Academy of Motion Picture Arts and Sciences presented to Karl Macher and Glenn M. Berggren on 6 April 1979 an award for outstanding technical achievement with the following citation: "The unique design of the Cinelux-Ultra lens achieves increased screen brightness, image contrast and sharpness in motion-picture projection." (*SMPTE Journal*, May 1979).

A contribution received on 24 September 1979 from Karl Macher, Jos. Schneider & Co., Optische Werke Kreuznach, D-6550 Bad Kreuznach, Postf. 947, West Germany. Copyright © 1980 by the Society of Motion Picture and Television Engineers, Inc.

5 mm. The specifications and aims of these newly computed lenses are based on their specific function.

Image illumination and screen brightness are the result of the relative aperture of a projection lens, the light transmission ca-

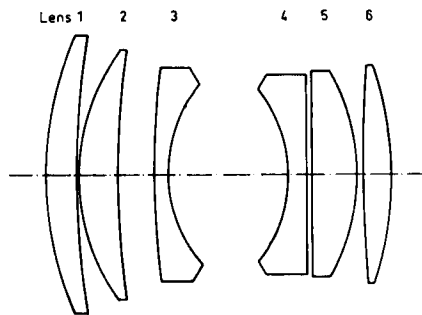

Fig. 1. Cross section of the Super-Kiptar $f/2.0$.

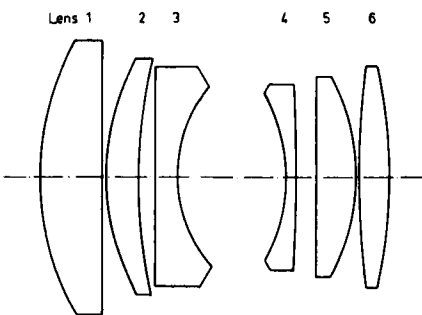

Fig. 2. Cross section of the Cinelux-Ultra $f/2.0$.

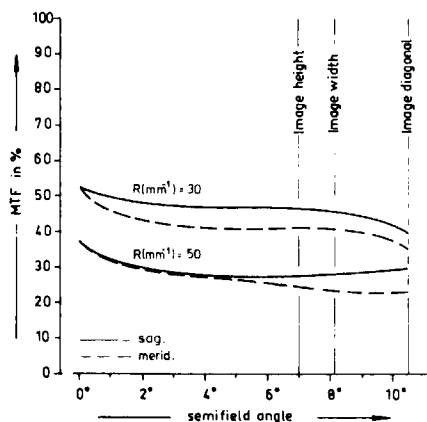

Fig. 3. Modulation transfer function of the Super-Kiptar $f/2.0$, 75 mm, for spatial frequencies of $R(\text{mm}^{-1}) = 30$ and $R(\text{mm}^{-1}) = 50$.

pability of the lens, and the light source performance of the projector. To utilize the projector's light source to its full capacity, a large relative aperture is required as well as an even distribution of illumination over the entire screen area. As a further condition, aberration correction depends on selection of the proper component glass. When choosing the glass for each element a high internal transmission factor must be strived for, because this is what determines, in conjunction with the multilayer coating, the overall light transmission factor of the optical system. If this practice is not observed, even a system with a large geometric relative aperture may offer no noticeable advantage over a system with a

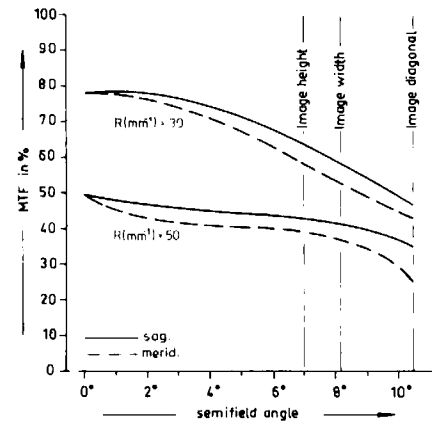

Fig. 4. Modulation transfer function of the new Cinelux-Ultra $f/2.0$, 75 mm, for spatial frequencies of $R(\text{mm}^{-1}) = 30$ and $R(\text{mm}^{-1}) = 50$.

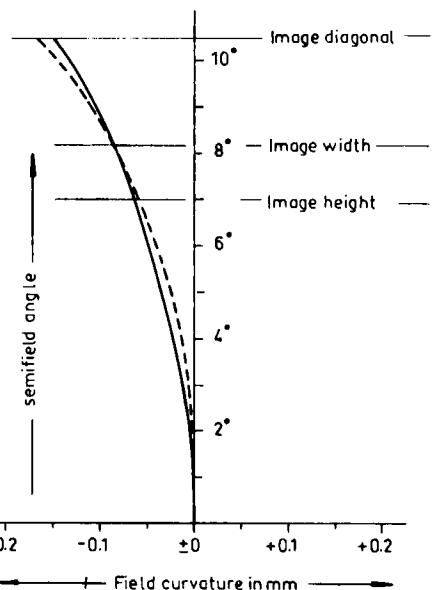

Fig. 5. Cinelux-Ultra $f/2.0$, 75 mm: field curvature (solid line) over the full image field for the sagittal and meridional image shell, taking into account a cylindrical film curvature around a vertical axis. Astigmatism (broken line) is insignificant as explained in text.

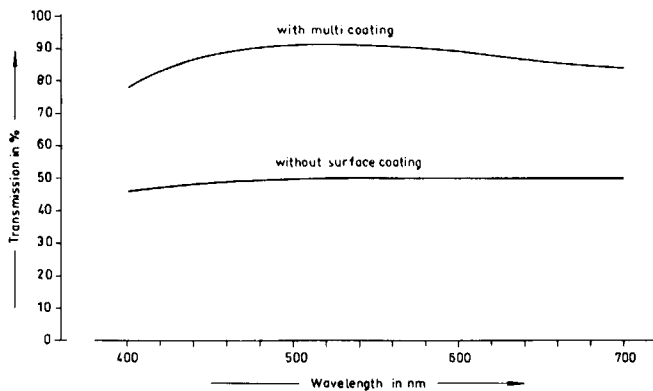

Fig. 6. Light transmission of the new optical design as a function of wavelength.

smaller aperture but with more favorable glass selection.

Optical Design

In trying to attain a superior image quality of the projected picture area at a relative aperture of $f/2.0$, starting from a picture format of 21.3×18 mm, the optical designer must define a number of lens elements having specific shapes in order to achieve equalized correction of aberrations. With a three-element four-lens construction of the Petzval type adequate image forming efficiency is attainable, as demonstrated by the earlier Kiptar series. If higher quality is demanded, at least a six-lens system becomes necessary. A design in the form of the Gauss double lens proved especially favorable. This general design was the basis on which the earlier Super-KiptarTM $f/2.0$ had been developed (Fig. 1). This basic form has been retained for the new Cinelux-Ultra system (Fig. 2); in the new lens system, however, new design concepts have yielded significant improvements in performance.

Both systems — the Super-Kiptar and the Cinelux-Ultra — contain four converging lenses in the outer positions (lenses 1 and 2, and lenses 5 and 6), and two diverging lenses with their concave surfaces facing each other (lenses 3 and 4). Lens elements 2 and 3, and 4 and 5, are deliberately not cemented as is usual in the Gaussian form. This prevents damage to the

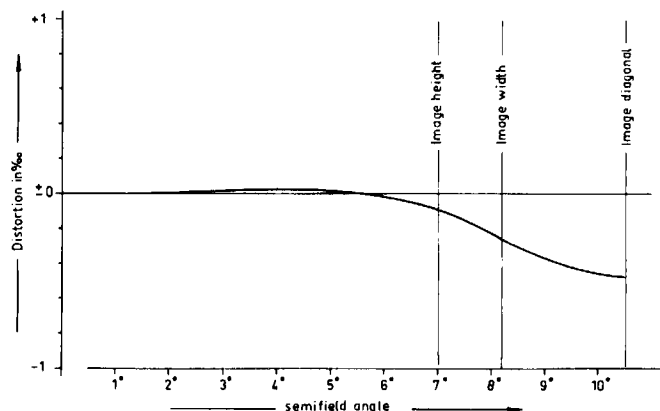

Fig. 8. Distortion of the new projection lens over the image field.

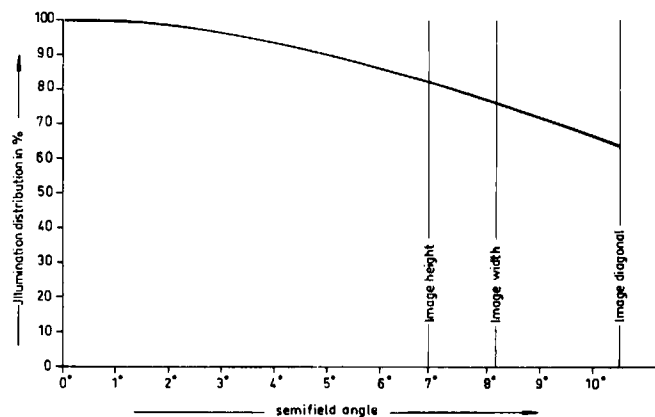

Fig. 7. Illumination distribution of the new design over the image field at infinity.

cemented elements due to heat from the light source. Also, in the new design, this use of uncemented elements permits optimum correction of aberrations.

When the film passes through the projector gate, the film plane usually curves across its width to a depth of from 0.10 to 0.20 mm. To compensate for this, an equivalent field curvature correction was built into the optical system. (Today's optical designer benefits, of course, from the use of computers and their associated programs.)

Imaging Performance

Let us take the Cinelux-Ultra $f/2.0$, 75 mm, as an illustrative example. For many years now the modulation transfer function (MTF) has been used to characterize the performance of optical systems. It describes the contrast within projected sine wave images of various specific spatial frequencies. Thus, we may define a contrast factor, K , as

$$K = \frac{(I_{\max} - I_{\min})}{(I_{\max} + I_{\min})}$$

where I_{\max} is the maximum screen illumination (or brightness) and I_{\min} is the minimum screen illumination (or bright-

ness) for a given spatial frequency. For $I_{\min} = 0$, the value of K is 1, and for $I_{\max} = I_{\min}$ the value of K is 0.

The MTF specifications for the Super-Kiptar $f/2.0$, 75 mm, and the Cinelux-Ultra $f/2.0$, 75 mm, are shown in Figs. 3 and 4. These graphs apply for an infinity setting with spatial frequencies of 30 and 50 line pairs per millimeter (abbreviated Lp/mm or mm^{-1}) respectively at the film gate, with white light, and with the above described film curvature taken into account. Figure 5 shows that in the picture with a horizontal angle of 8° the film curvature is about 0.10 mm, while the astigmatism, i.e. the difference between the sagittal and the meridional image shell, is insignificant.

The decided advantage of the new design can be clearly seen from the MTF graphs (Figs. 3 and 4); especially interesting is the relation of the value at the image center to the value at the full width (8°) of the image. This particular range is of special importance in evaluating the image quality of the projected picture.

To fully appreciate the efficiency of the new optical system, one may refer to Figs. 6 – 9. Figure 6 shows transmission vs. wavelength throughout the visible spectrum between 400 and 700 nm, with and without a multilayer surface coating; the

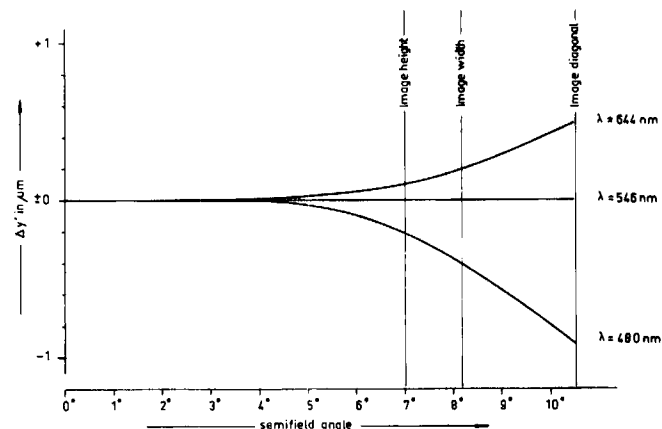

Fig. 9. Lateral chromatic aberration of the new optical system over the image field of red ($\lambda = 644$ nm) and blue ($\lambda = 480$ nm), expressed as deviations relative to the green reference color ($\lambda = 546$ nm).

difference is so drastic and noticeable that no further comment is necessary. Relative illumination distribution over the image field at infinity is illustrated in Fig. 7. Permill distortion (distortion in parts per thousand) is graphed in Fig. 8, also over the full image width; again, no significant deviation appears. Figure 9 shows clearly that the lateral chromatic aberration for red ($\lambda = 610$ nm) and blue ($\lambda = 480$ nm), taken against green ($\lambda = 546$ nm) as the reference color, is virtually nil and, therefore, no visible color fringing appears within the image. (Note that the lateral chromatic aberration over the image field is shown in micrometers in Fig. 9.)

In a projection lens, no iris diaphragm is required, and thus all the foregoing data have been quoted for maximum relative aperture. Also, all results are quoted for an infinity setting because — in practical use — the projection distance is so large in relation to the focal length of the lens that an exact focus adjustment will not alter the

imaging quality. The new Cinelux-Ultra series will accept (as does the Super-Kiptar series) an anamorphic supplementary lens.

Conclusions

In addition to the development of completely new optical systems, an important task for the lens manufacturer is to update existing lens designs and thereby to advance the state of the art. The description of the salient features of the new optical projection system shows a very definite quality improvement over the original system. This advance — obtained with no substantial extra expenditures — can be ascribed to the setting of more precise initial specifications, to the use of new design concepts in conjunction with modern methods of calculation, and to the use of new optical materials.

In the series production of any technical product, one has to take into account the inevitable manufacturing tolerances. This

also applies, of course, to the production of optical systems. So as not to impair the technical advances achieved in the new series, these tolerances have been set within exceptionally tight limits. Finally, appropriate computations determine the type of mechanical construction and the methods of production. In the image forming chain from the subject to the camera, through the printer, and to the projected picture, the projection lens is the final link of the chain, and as such it has a decisive influence on the image quality of the picture on the screen. Because a considerable expenditure of money and effort goes into the production of a film (particularly an entertainment film), the optical reproduction system is of utmost importance if the finished work is to be presented without any loss of quality to an audience. Using a proper optical reproduction system, consisting of specially calculated high performance lenses, fulfills the demand for faultless picture reproduction.

Multilingual Television

Addendum to the Progress Report on Canada in the May 1980 issue of the SMPTE Journal

CFMT-TV, Canada's first multilingual television station (referred to as MTV) became a fledgling entity in the highly competitive Toronto market on 3 September 1979. MTV entered into the market place with a mandate unlike any other in the North American continent — to provide a television service that both English-speaking and non-English-speaking viewers could relate to and enjoy. The English language is used in about 40% of the programming with the remaining 60% multilingual. MTV is now broadcasting in some 20 languages within the broadcast week.

Some of the problems involved in dealing with multilingual programming include: (1) doing 20 different audio carts for one commercial; (2) the inability of studio crews to communicate in the sponsor's language; (3) the inability of the Director to communicate with the sponsor; and (4) special character generator requirements.

As in most cases, the broadcast facilities were assembled within a remarkably short time frame. MTV acquired a 20-year lease on a government building which had formerly been a warehouse for a large food chain and, as can be imagined, the interior of the building (78,000 ft² or 7,250 m²) had to be thoroughly renovated. Construction, based on plans drawn up by Raymond Moiryama Architects, began on 4 June 1979, a mere three months before the scheduled "sign on." We are certainly pleased to report that all schedules were met and the result was a thoroughly renovated warehouse turned television center.

The center also houses a printing and newspaper operation.

MTV is manned by a full time staff of 115 members, headed by President Dan Ianuzzi, which includes a nine-member Engineering staff.

The station broadcasts from the CN Tower on UHF channel 47. The transmitter is a Townshend TA, 55 NET, 55 kW using a tetrode aural and klystron visual with a pye driver, purchased through Comad Communications and installed by Townshend Associates and Immad.

There looms a distinct possibility that the high end UHF stations in Canada may be asked to relocate to mid-band UHF. As it turns out, a local station falls into this category. In order to prepare for the future, MTV entered into an agreement which provides for a channel 47 and 41 antenna, combiner, patch panel and power divide system. This equipment was supplied and installed by EMI. The antenna system is an EMI-slot eight-tier system with a 90-kW capability. The antenna transmitter combination provides coverage that radiates an "A" contour approximately 90 km in radius giving a potential viewing market of three million. At present CFMT is on 50 cable companies within its coverage area.

Studios and Equipment

At the television center, three studios were constructed to handle commercial production, program production and live programming. EMI 2005 and Philips PC60 cameras are used in these studios. The

switching is accomplished by a Ross 500-5-24 switcher which has proven to be both reliable and versatile enough to meet the production requirements. The audio mixing is by a Ward Beck 20 × 4 × 2 which has proven more than adequate for all applications.

Master Control was designed to be functional as both MCR and Studio Control Room for off hours or live programming. The switcher was provided by Image Video. The unit has standard MCR requirements plus DSK, CHK, auto fade and programmable wipes. The central equipment area contains standard gear. Approximately 70% of all the equipment is manufactured in Canada.

Sony provided three editing units, the BVU-200A, BVE500A and the BVH1000, and also provided six BVU-200As which are used for all commercial playbacks.

The MTV mobile has a three-camera capability. Purchased from a local university, it has seen much action, particularly for sports events. The truck is equipped with three Fernseh KC P-40 cameras. It will shortly be rebuilt to carry four cameras, one "C" format VTR and Slo-Mo.

A CFMT subsidiary has been allocated channel 200 of Anik A03 Transponder II. This is on an experimental basis but is expected to become a permanent part of CFMT programming. At first, 63 hours per week will be broadcast including many ethnic-oriented programs.

Through MTV America, MTV will air some of its programs in the United States on a delayed basis, sold mostly to cable companies for community access programming; in some cases the programs will be viewed on basic service.