

A Simple Family of Digital Filters for a Binary Hierarchy

By JOHN P. ROSSI

The concept of a binary hierarchy or family of TV picture quality levels is described. A family of digital filters designed for such a binary hierarchy is introduced. The main advantage provided by these filters is that they can be used to perform most up-conversion and down-conversion processes while utilizing essentially the same hardware components, the same boards, and the same layout. The filter's function is changed by means of wire jumpers and external control signals. The family concept can be extended to more complex filters. The use of these filters in the Digital Hierarchy Demonstrations is described.

Introduction

It is generally agreed that for production purposes it would be desirable to establish several levels of picture quality, and to relate an appropriate coding standard to each quality level. The problem is selecting appropriate coding standards for the desired set of quality levels. Obviously, one important consideration is the technical problem of translating from one level to another. This problem is greatly simplified by requiring the different coding standards to belong to some hierarchy, i.e., to require the sampling rates of the different standards to be related to each other by integral ratios.

There are several quality levels in a television system, but there are at least three quality levels that have major importance for the broadcaster. The highest level, of course, is needed for production purposes. That should be able to accommodate picture recomposition, including chromakeying and other production effects. Another level of this hierarchy would provide studio and broadcasting quality pictures. A third level would be used for electronic

newsgathering (ENG) applications, where equipment size and tape consumption might dictate a reduction in quality. Other hierarchy levels for special applications may also be desirable.

Technically, the hierarchy which is easiest to handle uses a base 2. It is also important to realize that the number of intermediate coding standards available between the two extremes in a hierarchy is the greatest when the hierarchy base is the smallest, which occurs when the hierarchy base is 2.

The technical difficulties in translating between different levels of a binary hierarchy had to be determined, so the design and the hardware implementation of digital filters and digital interpolators that might be used in such applications were undertaken. It should be emphasized that the goal was not to design the perfect filter or interpolator. The main objective was to derive easily realizable filters that had the potential of providing reasonable performance.

Technical Discussion

In a digital hierarchy one must be able to translate between the different levels with reasonable accuracy and cost. Moving down the hierarchy lev-

els, the alternate video samples can simply be dropped as long as the resulting sampling rate is super-Nyquist (above the Nyquist rate) with respect to the video signal. In most cases, however, video prefiltering will be required. The low-pass filter used in these applications will have to attenuate video frequencies above one half of the final sampling rate. The amount of attenuation required at those frequencies has not yet been determined. It will certainly be influenced by the types of processes subsequently applied to the video signal. There are some indications, however, that for the color difference signals, a considerable level of aliasing can be tolerated as long as this alias does not interfere with other video processes.

Going up through the hierarchy levels, missing video samples must be regenerated by interpolation techniques. An interpolator can be viewed as a low-pass filter. The ideal interpolator would have unity transmittance everywhere within its passband and zero transmittance outside its passband. The cutoff frequency would, of course, be equal to one half of the input signal's sampling frequency.

For practical purposes, of course, it is necessary to find a compromise regarding the frequency characteristics of the interpolator. One attractive

AUTHOR: Manager of Digital Television Development, CBS Technology Center, Stamford, Conn.

approach might be to design the interpolator so that it has the same characteristics as the low-pass filter down-converter. This opens up the possibility for the use of similar basic designs.

It should be kept in mind that different levels of a hierarchy can be defined as having either orthogonal or line-interleaved sampling patterns. Field-interleaved sampling patterns may also provide some advantages.

The simple, orthogonal-sample transcoders are associated with the filtering requirements shown in Fig. 1. Note that, for down-conversion, a low-pass filter is needed with a frequency cutoff at one quarter the input video sampling frequency.

When an extended frequency response is desired, the down-converter can use a quincunx* sampling structure and employ sub-Nyquist sampling techniques to retain video frequencies, let us say, out to $\frac{3}{8}$ the input video sampling rate. This $\frac{3}{8} F_s$ filter will require special considerations which will not be dealt with at this time. The up-converter for a sub-Nyquist sampled signal will need a comb filter, a bandpass filter, and a low-pass interpolator filter. Such a converter is shown in Fig. 2, together with the frequency response requirements for the associated filters. We then have a multiplicity of filter requirements.

Family of Filters for Binary Hierarchy

Without going into the details regarding the derivations, the following filters were designed in order to evaluate digital-to-digital translations between different levels of a binary hierarchy. These filters make use of the same building blocks, the same layout, and the same components. They have insignificant design differences and require no multipliers or read-only memories (ROMs). The filters have linear phase response and their frequency response characteristics appear to provide a good compromise between the ideal and the inexpensive.

Two-to-One Digital Down-converter Low-pass Filter

As mentioned previously, a sampling rate reduction by a factor of 2

* A quincunx pattern consists of a basic unit of five points with four of them at the corners of a square and the fifth in the middle of the square.

requires a low-pass filter with an instantaneous cutoff at $F_s/4$. It should be emphasized that, if the input signal does not contain any significant energy above $F_s/4$, then the filter operation is not needed and, in fact, it is not desirable. In that case, one can proceed immediately to the lower sampling rate by dropping alternate video samples. It would indeed be useful if the digital video signal would contain an identification code relaying information about the frequency responses of the signal. It will also be important to establish fixed video frame format standards for video samples at any level of the hierarchy.

For the two-to-one converter, a low-pass filter having the following transfer function (in the z domain) is used:

$$H(z) = \frac{1}{2} [1 + (\frac{1}{2} + \frac{1}{8})(z^{-1} + z) - (\frac{1}{8} + \frac{1}{32})(z^{-3} + z^3) + \frac{1}{32}(z^{-5} + z^{-5})]$$

The frequency response of this filter is shown in Fig. 3. Note that it is exactly 6 dB down at $F_s/4$.

The Up-converter One-to-Two Interpolator

The interpolation process can be viewed as a low-pass filtering operation where the filter's cutoff frequency is at $F'_s/2$. (See section *Technical Discussion*.) Note that F'_s is the input signal's sampling frequency, which, in Fig. 1, corresponds to one half the sampling rate of the original signal (prior to down-conversion). The interpolator for the up-conversion uses the same algo-

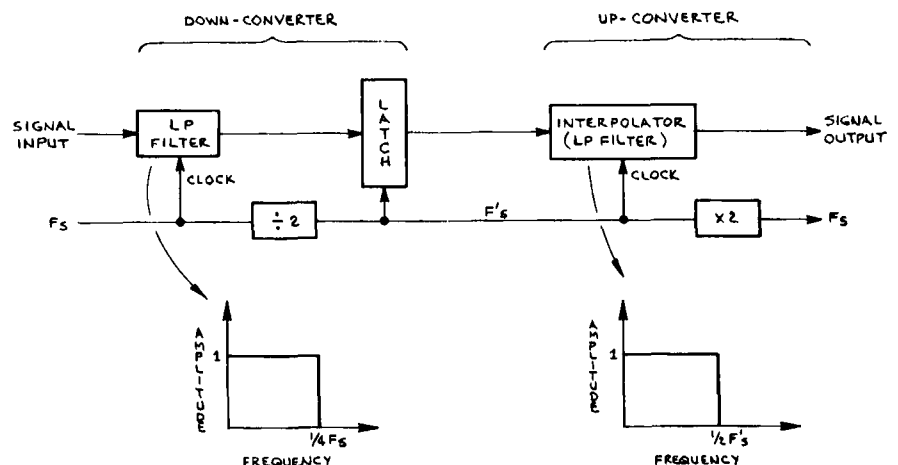

Figure 1. Simple transcoding in a binary hierarchy.

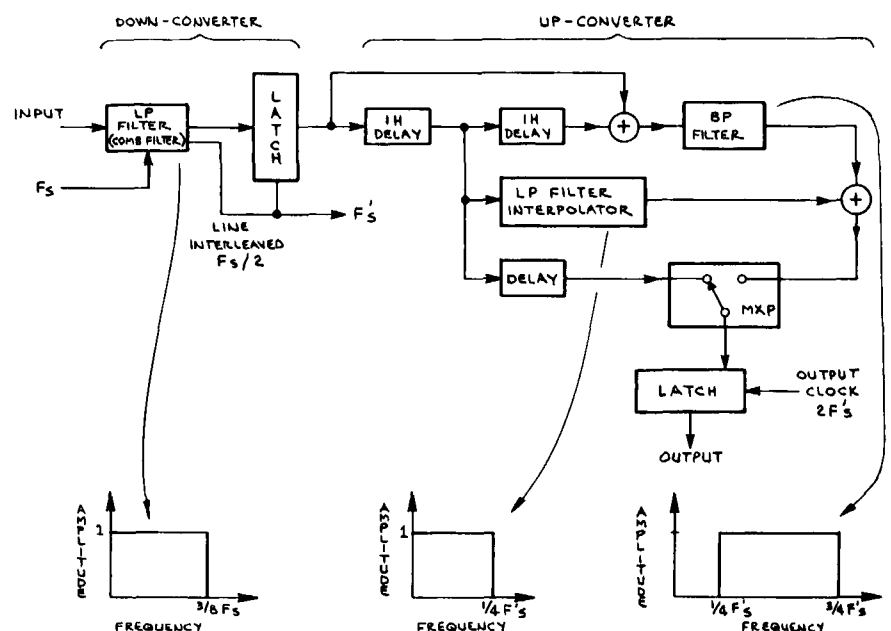

Figure 2. Transcoding using sub-Nyquist techniques.

rithm as the down-converter, and it has exactly the same frequency response characteristics.

Comb Filter Interpolator for the Y Channel

At the 2:2:2 or the 2:1:1 hierarchy levels, the Y signal is sampled at sub-Nyquist rates. A line-interleaved sampling structure is used.

As shown in Fig. 2, the comb filter up-converter requires a low-pass filter interpolator and a bandpass filter. It is clear that the low-pass filter requirements for the interpolator are exactly the same as for the low-pass filter converter of Fig. 1, and, in fact, the same filter can be used.

The actual intersample interpolation is obtained by simply averaging two adjacent samples. That process introduces less than 2 dB additional attenuation at $F_s/4$.

The bandpass filter in the comb filter has the transfer function

$$H(z) = \frac{1}{2} [1 - (\frac{1}{2} + \frac{1}{8})(z^{-1} + z) + (\frac{1}{8} + \frac{1}{32})(z^{-3} + z^3) - \frac{1}{32}(z^{-5} + z^5)]$$

It is evident that, except for the signs of the coefficients, this bandpass filter is the same as the low-pass filter. The frequency response of the bandpass filter and of the low-pass filter interpolator combination are illustrated in Fig. 4.

Digital Hierarchy Demonstrations

The techniques described for the binary digital transcoding processes were incorporated into the CBS-built equipment used to evaluate a digital hierarchy at the SMPTE Digital Hierarchy Demonstrations in San Francisco. Figure 5 shows a complete block diagram of that equipment.

The inputs to the system are the analog R, G, B, and S (Sync) signals. The R, G, and B signals are matrixed into Y, R - Y, and B - Y signals.

Horizontal drive is derived from Sync and it is used to lock three crystal oscillators: one at 912 H, one at 864 H, and one at 768 H, where H is frequency of horizontal drive.

R, R - Y, and B - Y are clamped and low-pass filtered prior to analog-to-digital conversion. The selection of the bandwidth (F_v) of the low-pass filters is determined by the sampling frequency (F_s) used for analog-to-digital conversion. Commercially available Matthey filters are used (FLM type). Table 1 shows the filters' bandwidth associated with each F_s .

The luminance signal (Y) and the color difference signals (R - Y and B - Y) are converted to 8-bit digital signals using three converters (TRW/TDC 1007J). At this stage, we have the 4:4:4 level of the hierarchy. The remaining digital processing circuits can be bypassed and signals delivered at the 4:4:4 hierarchy levels

Table 1 — Bandwidth of Filters Associated with Each F_s

F_s	F_v (-3 dB)
912 H	5.9 MHz
864 H	5.6 MHz
768 H	5.0 MHz
456 H*	5.0 MHz
432 H*	4.6 MHz
384 H*	4.16 MHz (Allen Avionics)

* Line-interleaved sampling.

directly to the digital-to-analog converters (DACs). Another possibility is to insert a digital down-converter and a digital up-converter in the R - Y and B - Y paths. Under those conditions one obtains the 4:2:2 hierarchy level (at the three possible F_s). There is also the choice of down-converting the R - Y and B - Y signals to the $F_s/4$ level and then up-converting again to the F_s level. Then, the performance obtained is of the 4:1:1 hierarchy level (at the three F_s).

Using line-interleaved sampling, the Y sampling rate can be reduced to $F_s/2$ and then up-converted back to F_s by means of a comb filter and digital interpolator. The 2:2:2 or the 2:1:1 hierarchy levels can then be viewed (at the three F_s).

The digital hierarchy demonstration equipment also has provisions to expand the picture in the horizontal direction. The expanders consist of small digital memories configured as FIFO (first-in, first-out) registers with independent input and output clocks. Picture expansion occurs when the read-out clock (F_o) is slower than the read-in clock (F_s). The process of interpolation, required for picture expansion, is performed in the analog domain by the low-pass filter following the DACs. Zero to 20 percent variable expansion is provided.

The digital signals are converted back to analog by means of three TRW DACs (TDC-1016J-8). They are low-pass filtered to 6.5 MHz and then matrixed back to RGB.

Sync information is carried by the Y signal in its blanking region and is recovered at the output of the Y analog-to-digital converter.

A digital output is also available just prior to the expansion circuitries. The tests performed at the San Francisco Demonstrations proved the feasibility of the filter family approach. Subjective evaluations of picture quality that were obtained by using these filters can be found in the following paper by David Bennett.

Figure 3. Frequency response of the low-pass filter and the interpolator.

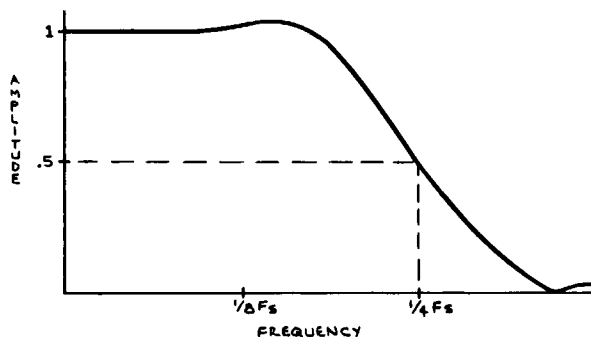
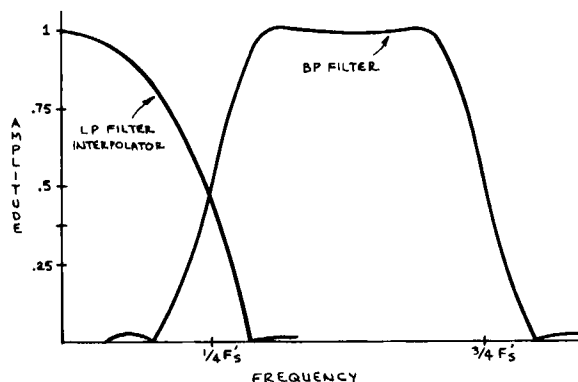

Figure 4. Frequency response of the low-pass filter interpolator and the band-pass filter.



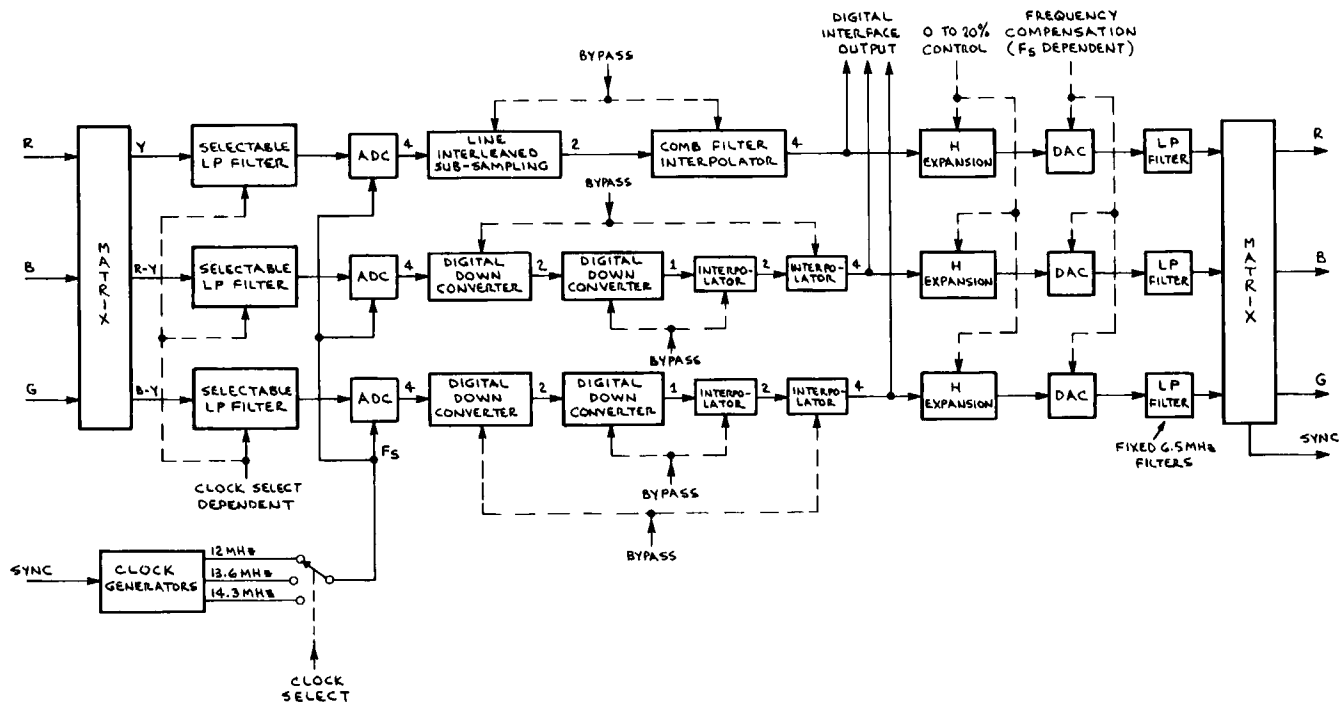



Figure 5. SMPTE hierarchy and picture-quality demonstrations.

Conclusion

The use of a binary hierarchy allows the utilization of a simple family of filters in most up/down conversion

processes. The filters that have been implemented do not necessarily represent the optimum choices. The principle of a family of filters, however, should apply, even if more coefficients

are to be added or different coefficients are desired for the filters. The filter family concept can have an important bearing on the cost and complexity of a digital hierarchy. 

Spouses Program to be Held at 123rd Conference

Mrs. Beatrice Hopkinson, Chairman of the Spouses Program of the 123rd Technical Conference, extends an invitation to all those interested in attending the Spouses Program and celebrating the Los Angeles Bicentennial (1781-1981) at the Century Plaza Hotel from October 25 to 30. The program will offer a "Californian Experience"—with visits to Hollywood studios, the Marina Yacht Club, a bit of old Venice, and a Spanish Rancho. There will be an unusual "private eye" of fashion—including the personal gowns of Nancy Reagan and other famous people, as well as an innovative beauty and fashion presentation. Visitors will take a ride on a carousel to the beat of Dixieland music, peek behind the scenes of the architecturally beautiful Music Center, lunch high in the sky with the stars, spend another day overlooking Malaga Cove, and sail among the yachts in the marina. Guests will pass through the bronze doors and climb a grand staircase of an unusual museum of "sight and sound" with crystal chandeliers and magnificent antique cars of yesteryear belonging to Rudolph Valentino, Fatty Arbuckle, and others, while listening to electronically captured orchestrations duplicating live performances on a concert grand piano, Kaiser Franz Josef's piano, and a Wurlitzer Pipe Organ. Music will be performed throughout the program, including folk music and square dance music. There will also be attractive door prizes and other gifts. Reservations can still be made for this interesting program—either by mail at SMPTE Headquarters or in person at the Conference in Los Angeles.