

---

## SECTION MEETINGS

---

**Detroit, June 16** — A screening of "Michigan A-V Showcase," a compilation of the best in educational, sales, industrial, medical, and informational programs made by Michigan audiovisual producers, highlighted the meeting held at Detroit's Buerki Auditorium, Henry Ford Hospital. Master of Ceremonies was Randolph Hippler, General Television Network. The presentations were limited to 16-mm motion pictures and 3/4-in U-matic videocassettes. No presentation was to exceed 10 min, so some were edited excerpts. A total of 24 entries was shown. The meeting, held jointly with the ITVA Detroit Chapter and the Detroit Producers Association, was attended by 110 members and guests. — John P. Rusche (Secretary-Treasurer), Sandy Corp., 16025 Northland Dr., Southfield, MI 48075.

**Florida/Caribbean, June 22** — The Martin Marietta Aerospace Corp. was the scene of the meeting and also the subject of the program. Rudy Taute, Manager of Audiovisual Operations, gave a multimedia presentation on the Aerospace Corp., its people, products, and future impact on the community.

Albert LeBoeuf, Supervisor of Photographic and Electronic Documentation, explained the applications of photo documentation in engineering. The SMPTE time code, digital data recording on film, and the phase-controlled shutter video were demonstrated. The equipment was available for hands-on demonstration following the program.

Charles Carter, Supervisor of Technical Operations, gave a presentation on video applications in production and engineering at Martin Marietta Aerospace. Engineer-



Charles Carter, Martin Marietta Aerospace, addressing the audience on video applications in production and engineering.

ing designs by the Audio Visual Technical Operations to modify production videorecording equipment to accept 875-, 625-, and 525-line video were demonstrated. These designs allow recording, editing, and reproduction of videotapes to military and commercial specifications with a minimum of equipment and cost. Large screen video projection illustrated day/night video surveillance systems and the role of the Audiovisual Department in the design and applications.

The effectiveness of the program was enhanced by slides, filmclips, and video clips used throughout the presentations. — James D. Caron (Manager), Cine-Craft, Inc., 105 Pineapple Lane, Altamonte Springs, FL 32701.

**Hollywood, June 15** — Robert Ringer, Ringer Video Services, moderated a program on "State of the Art in Tape-to-Film Transfer Systems and Facilities" for an audience of 230 in USC's Eileen Norris Theater. The five speakers were Thomas Mann, Image Transform; Arthur Schneider, Consolidated Film Industries;

John Truckenmiller, Crest Film Laboratories; James Wada, NAC & Yokohama Cinema Laboratories; and Mr. DeTerville, Teledyne Camera Systems.

Each of the speakers presented a short demonstration film and then explained his firm's approach to the transfer process. James Wada described the NAC 16-mm laser beam recorder and answered a number of questions from the audience about this system.

John Truckenmiller and Mr. DeTerville showed examples of the Teledyne system. Arthur Schneider explained the CFI system and showed some examples of the system's operation. Thomas Mann showed an example of the Image Transform system. Robert Ringer displayed his Ringer Video for the first time. — Charles D. Kircher (Secretary-Treasurer), Foto-Kem Industries, 2800 West Olive Ave., Burbank, CA 91505.

**New York, May 12** — Satellite Communications was the subject of the May meeting, which was attended by about 200 members and guests. The first speaker was Mary Lou Durham, Marketing Manager, Commercial Telecommunications, Scientific-Atlanta Inc., who gave an outline of the history of earth satellites. She then presented an engineering overview of the present and future performance characteristics of satellites and earth stations. She pointed out that almost half of all broadcasters now have earth stations. There are now 10 satellites in orbit, and by 1987 there will be 26, Miss Durham said.

Bill Johnston, Manager, Technical Operations, and Walter Nichol, Engineering Manager, Group W Satellite Communications, presented a paper on the design and operational facilities of the new Stamford and Washington news production centers. These facilities are being designed to support the new 24-hour news channel cable service to be offered in June 1982.

Both presentations were enhanced by well-selected slides.

The questions directed to the speakers



Audience at Florida Section Meeting held at Martin Marietta Aerospace.

**“I want the world.  
Consistent .05% corner registration  
and full auto-setup of up to 96  
cameras on computer command.”**

**AUTO  
SETUP**

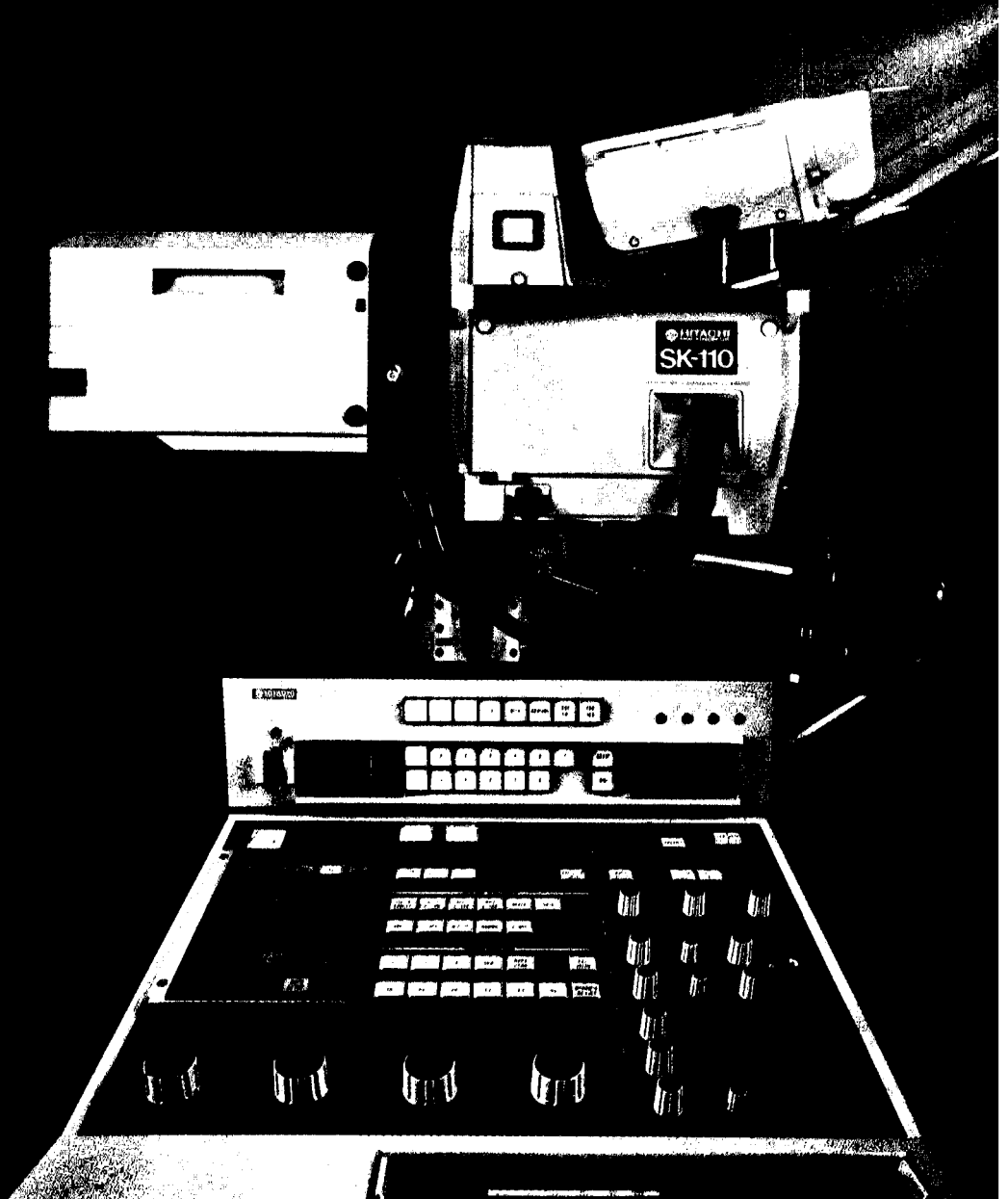

# Camera Mart and Listec

What's in the name? Plenty! Listec is the name for quality mounting and monitor prompting equipment, superbly engineered, equipment that has won the Guild of Television Cameramen's award. And Camera Mart is the name that has won the respect of the industry's top professionals for its personalized, knowledgeable concern for every

client's special needs. So check out New York's most extensive collection of Listec equipment at Camera Mart. Which unit do you need? You name it, Camera Mart has it. Listec and Camera Mart—two names you can really rely on.

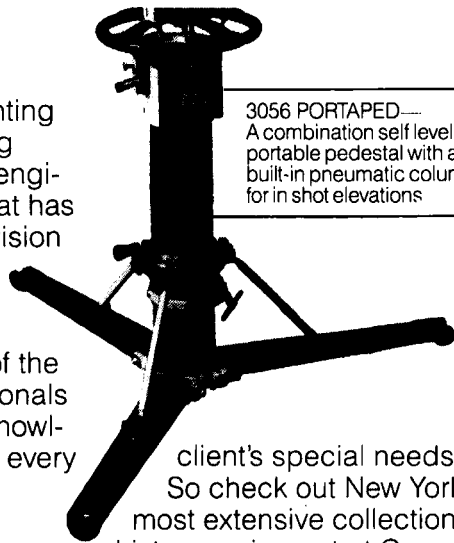

**3056 PORTAPED**—  
A combination self leveling portable pedestal with a built-in pneumatic column for in shot elevations

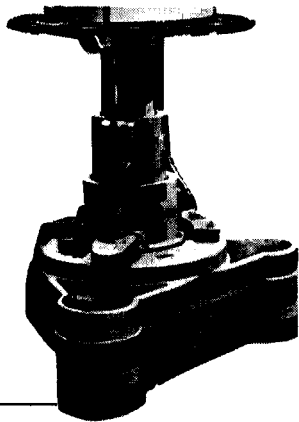

**3702 FULMAR EXTENDED RANGE PNEUMATIC PEDESTAL**  
Unsurpassed for stability, heavy weight capacity, finger tip control.

**DIGIVISION MONITOR PROMPTING SYSTEMS**  
A light weight, broadcast engineered, black and white monitor, hood and semi-transparent high quality mirror, weight 22 pounds. Used by network and major broadcasting stations.

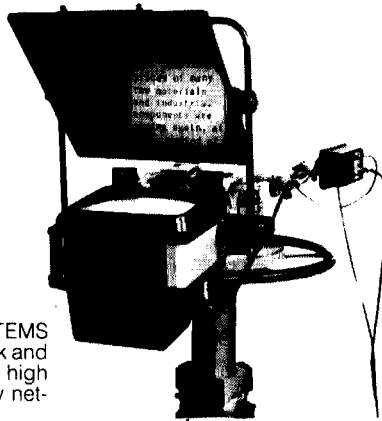

## The Camera Mart, Inc.

456 West 55th Street, New York, NY 10019 (212) 757-6977 Telex: 1-2078

Sales • Service • Rentals

SEE US AT SMPTE BOOTHS 59, 60, 70, 71, 143

covered such topics as "Who is going to pay?" and "Why Connecticut?" One questioner asked Miss Durham about the vulnerability of satellites to attack by an enemy. She replied, "Why would anyone want to shoot down Donald Duck?"

The meeting was held at the United Engineering Center. Hospitality was provided by Tape-Films Inc. — Richard Marcus (Secretary-Treasurer), Richard Marcus Productions, 1380 Riverside Dr., New York, NY 10033.

**New York, June 18** — The Old Coach Restaurant in New York City was the scene of the annual social get-together. High point of the evening was the 1981 Clio Awards film. Following the film showing, the 180 members and guests enjoyed a buffet of Italian delicacies. Other events included dancing to disco music until a very late hour. The events of the evening were arranged by Past Chairman William Cooper. — Richard Marcus (Secretary-Treasurer, Television Engineering Consultant, 1380 Riverside Dr., New York, NY 10033.

**Philadelphia, June 16** — First item on the program was a tour of the NFL Films modern production facilities where NFL Films produces segments for the networks in addition to a syndicated program, "NFL Review and Preview." The tour for the 52 members and guests was conducted by Art Spieller, host for the meeting. Following the tour, Terry O'Neil, producer for CBS Sports, showed a film, *CBS at the Super Bowl*. O'Neil is the recipient of two Emmies, and recently produced the telecast of *Super Bowl XVI*. The film gave a behind-the-scenes look at the preparations necessary for the live broadcast of the Super Bowl. After the film O'Neil spoke about camera positions and instant replay. Using a blackboard and charts, he explained the assignments of each of the 23 cameras. Videotaped excerpts from *Super Bowl XVI* were shown on an Advent TV projector. — Michael Muderick (Secretary-Treasurer), Penn Mutual Life Insurance Co., 101 Earlington Rd., Haverstown, PA 19083.

**Rocky Mountain, June 18** — The annual Summer Social Meeting, highlighted by the presentation of awards to the section officers who served during 1981, was held at the beautiful Lakewood Country Club. Following an excellent dinner served to 57 members and guests, the 1982-1983 sections officers were introduced followed by the awards presentations. A fascinating look back to the section meetings of a decade ago was provided by a slide presentation which showed the faces of 1972 and unusual events that took place during that year. Lester Dunn, who was Section Chairman in 1972, was presented with an award for his service during that year and since that time.

After these events the guest speaker,

# TOTAL PERSPECTIVE

**With the most dazzling video effects. That's what you get with ADO, Ampex Digital Optics.**

ADO is the new generation of digital optics, a system so advanced that it easily creates the most exciting three-dimensional video effects ever produced, effects once the exclusive domain of film.

With ADO you can alter perspective, geometry, and picture size in real time, on up to four separate video channels. You can rotate a picture about all three axes and execute flips, tumbles and spins more smoothly than on any other system on the market today. And what's more, you do it all in true, three-dimensional perspective!

Operation is simple, too. Since the ADO is user programmable, all you do is manipulate a few buttons and modify the image with Ampex's unique joystick control.

And with 100% digital video processing, your output is identical to your input, totally transparent. Your result? The best, most creative picture on the air.

For more information, contact your Ampex sales representative or write Ampex Corporation, Audio-Video Systems Division, 401 Broadway, Redwood City, CA 94063 (415) 367-2011. Sales, spares and service worldwide.

## AMPEX TOOLS FOR TOMORROW

Ampex Corporation • One of The Signal Companies [9]

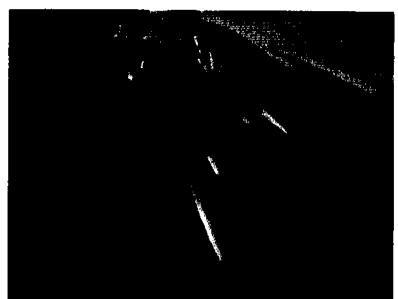
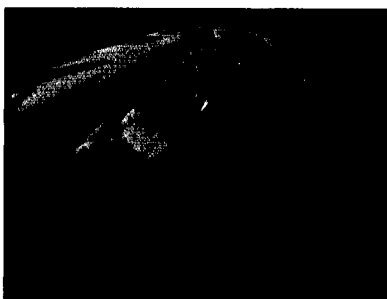
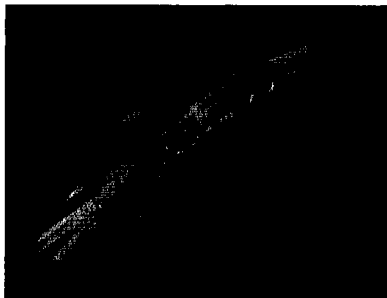
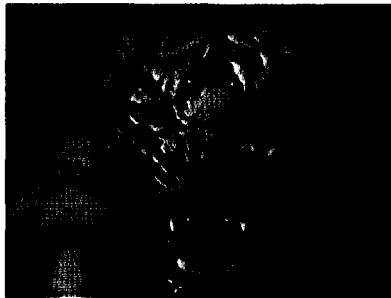

Actual unretouched ADO images.

# THE TRUE MEASURE OF PERFORMANCE

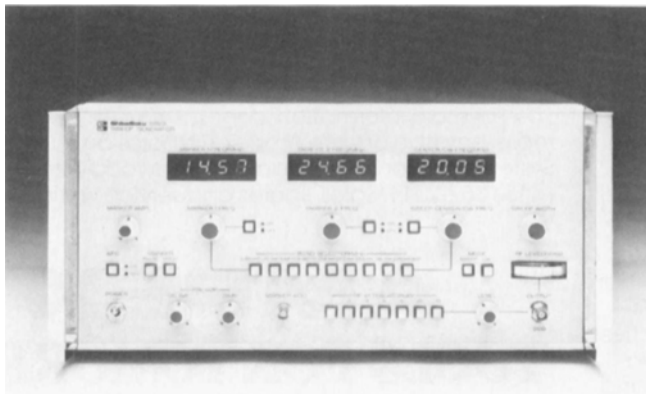

## ASACA/SHIBASOKU SR22 RF Sweep Generator

The SR22 covers an 860 kHz to 440 MHz range in 9 bands. Each band has a double frequency range and can accommodate one sweep throughout the entire area of the band. Sweep width may also be varied continuously down to a minimum of 1% of center frequency.

- 2-wave, pulse-shaped variable frequency marker.
- Sweep center frequency marker driven by luminance modulation.
- External frequency marker uses oscillator signal.
- Built-in frequency counter.

### Output Signal Frequency Sweep Width (MHz)

Frequency	Max.	13.8~27.5	13.8
0.86~1.72	0.86	27.5~55.0	27.5
1.72~3.44	1.72	55.0~110	55.0
3.44~6.88	3.44	110~220	110
6.88~13.8	6.88	220~440	220

Minimum sweep width: 1% of center frequency.

Measure your performance with the best. **ASACA/SHIBASOKU SR22.** The wide band RF sweep signal generator.

For complete specifications, write:

# ASACA

ASACA/SHIBASOKU CORP. OF AMERICA  
12509 Beatrice Street, Los Angeles, California 90066  
Sales, Service: (800) 423-6347 • (213) 827-7144

Fred Dressler, President of Mile Hi Cable in Denver, gave the audience some educated predictions about the future of communications, suggesting a number of alternatives.

Following Dressler's presentation, the audience was entertained by the annual showing of on-air/off-air "bloopers" made by local and national news personalities. — Arthur B. Rancis, 3143 West 12th Ave. Ct., Broomfield, CO 80020.

**San Francisco, June 17** — A presentation on the new Ampex VPR-80 and a tour of the Ampex Museum of Magnetic Recording were the highlights of an unusual program held at Ampex headquarters in Redwood City, Calif., attended by about 115 members and guests. Jim Peterson, Ampex, told the audience that in the designing and developing of the VPR-80 teleproduction recorder, the emphasis was on the effect of microprocessor control and the use of improved manufacturing techniques to produce a higher-quality, lower-cost 1-in broadcast VTR.

Peter Hammar, Curator of the Ampex Museum, gave a brief description of the newly opened museum and invited members of the audience to tour the museum at their own pace. The museum is beautifully crafted and contains a remarkable collection of machines, photographs, and information, tracing the history of magnetic recording from the earliest audio machines to modern video recorders. Typical of the pieces in the collection are a Magneto-phon "Berthe" in German Army field trim complete with rotating heads, as well as the refurbished console of VRX-1000 serial number 4, one of the first 16 video recorders placed in customers' hands in 1956.

Those in attendance spent several hours enjoying coffee and cookies and gaining hands-on experience with the VPR-80 and examining a history of recording developments that have changed all our lives. — Glen Pensinger (Secretary-Treasurer), San Jose University, 958 Jeanne Ave., San Jose, CA 94303.

**Toronto, June 10** — David George, President of Imagineering Ltd., spoke on "Television Encoding Techniques," predicting that Pay TV will make its debut in Canada early next year. He told the 105 members and guests assembled at George Brown College, "While it may be free for a short while to build up the interest in the



Section Chairman Howard Wilkinson (L) and Speaker David George during the intermission.

# SOUNDS LIKE THE PERFECT COMBINATION.



Rank Cintel now brings you the finest double-act in the business: the MkIIIIC telecine and the FeRRIT sound follower.

**The MkIIIIC** is a development of Rank Cintel's world leading flying-spot

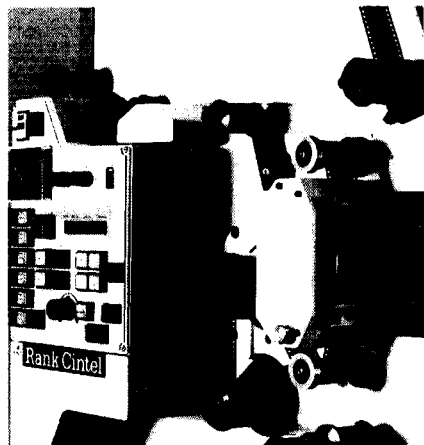

*The FeRRIT sound follower*

telecine. The advantages of using the light-source to scan the film are plain to see, particularly with negative film: pictures that are high in contrast, resolution and definition but low in

noise. Flying-spot picture quality and operational features like 16mm/35mm/Super 16/Super 8/slide capability, programmed color correction and variable speed between 16 and 30 f.p.s. make the Rank telecine the definitive film/tape transfer machine.

**The FeRRIT** is a triple-gage interlocking sound follower for telecine, VTR and dubbing applications. Available for 16mm, 17.5mm and 35mm operation, it combines proven audio design, micro-processor servo control and a transport configuration derived from the industry standard MkIII telecine mechanism.

Other exciting features that make the FeRRIT a real winner include: rapid changeover between formats; capstan drive without pinch rollers; 24 and 25 f.p.s.; up to 6 audio channels; continuously variable shuttle control; A/B wind and operation in either the synchronous or asynchronous mode.

By anybody's standards; the FeRRIT is a sound investment in reliability, versatility and, above all, quality. For the Rank Cintel telecine

user, there is the added bonus of system, spares and technology compatibility.

For the impressive facts on the MkIIIIC and FeRRIT, contact your nearest **Rank Precision Industries Inc.** office:

260 North Route 303, West Nyack, New York 10094. Telephone (914) 353 1914. Telex 646998.

13340 Saticoy Street, North Hollywood, CA 91605. Telephone (213) 765 7265. Telex 182694.



**Rank Cintel**

The world leader in telecine.

service, it won't be delivered free for very long." He said that quite likely cable will be used to deliver Pay TV signals wherever a cable system exists. The TV signal is encoded, scrambled, encrypted and trapped within the first place to prevent unauthorized reception. Various methods, such as jamming carriers, trapping systems, and scrambling were explained. George demonstrated scrambling and descrambling with Leitch Video equipment. The presentation was illustrated throughout with 35-mm slides.

Brian Olsen, Manager of Broadcast Services, Telesat Business Development Dept., outlines Telesat Canada's capabil-

ities and plans, including the launch of ANIK-C satellites (three 16-channel satellites) planned for sometime between 1982 and 1985. These provide high density, high speed links between Canadian destinations. Also, Pay-TV will use ANIK-C on the 14-12 GHz band. Three main topics were covered in the paper, first, deployment of the satellites; second, design features — each satellite has 16 channels of 54 MHz bandwidth covering all of Canada south of latitude 60°N; third, use of the satellites by Pay-TV operators. — Fung Fai Lam (Secretary-Treasurer), Sony of Canada Ltd., 1325 Melton Dr., Mississauga, Ont., Canada L4Y 1L6.

LaVeZZi's reputation for precision components has been unmatched in the film industry since we first manufactured sprockets for cinema projectors in 1908. Our component designs have contributed to improvements in film presentation and reductions in film maintenance. The quality has improved equipment reliability.

Equally important to the film industry, LaVeZZi gears, shafts, cams, clutches, eccentrics and other components are contributing to the reliability of camera operations, in the control of film in projectors and cameras, in film processing operations, and in tape transfer systems. These parts are manufactured by people who can machine complex designs to strict specifications, and who care about

quality. It's the LaVeZZi way of doing a job!

Our customers take pride in their LaVeZZi machined components. They know it contributes to equipment reliability. When you need quality components, ask for "Precision Machining Capabilities" and see how LaVeZZi Close Tolerance Components can improve your equipment reliability.

*LaVeZZi*

LaVeZZi Machine Works, Inc.  
900 North Larch Avenue  
Elmhurst, Illinois 60126  
(312) 832-8990  
Out of state, call toll free  
800-323-1772

## Precision machined components for cameras, projectors, film and tape processing equipment.

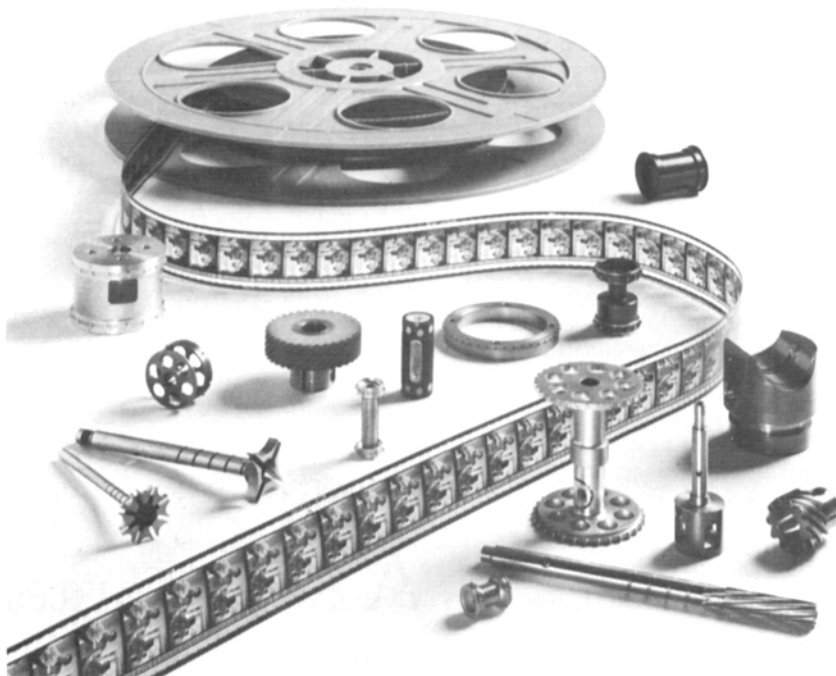

## NEWS

**Robert Auguste** has been appointed Vice-President, Engineering, Cinema Products Corp., it was announced by Ed DiGiulio, Cinema Products President. He will assume complete responsibility for all Cinema Products design and development efforts with particular emphasis on the company's expanding video

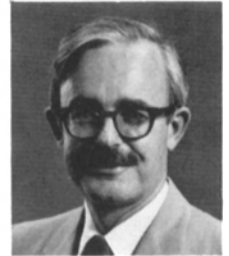

equipment line. An electronics engineer by training, Auguste joined Cinema Products Corp. as Chief Engineer in 1968, the year the company was founded. In subsequent years, Auguste has personally, and for Cinema Products, received three Academy Awards: for the development and introduction of a new crystal-controlled lightweight motor for the Arri 2C camera; for the J-4 servo zoom control system; and for the design and development of the Steadicam film/video camera stabilizing system.

**Walter S. Ciciora** is the recipient of the Best Paper Award from the Consumer Electronics Group of the Institute of Electrical and Electronics Engineers (IEEE) for his paper, "Twenty-Four Rows of Videotex in 525 Scan Lines." In the paper he explains several techniques for videotex displays. Dr. Ciciora has been with Zenith Radio Corp. for 17 years. He is currently Director of Sales and Marketing. He has been a member of the SMPTE since 1976.



**Leon D. Selznick** retired July 1, 1982, as Vice-President of Sales, Ryder Sound Services. He joined the firm as a sound technician in 1954 and had been with the company for 28 years, serving also as Sales Manager and Advertising Director. For a number of years he worked in close association with



Loren L. Ryder in the introduction of 1/2-in portable tape recorders, first the Perfectone and then the Nagra recorder. Selznick is a member of the Academy of Television Arts and Sciences and a member of the Academy of Motion Picture Art and Sciences. He has been a member of the SMPTE since 1962.