

American National Standard specifications for 8-mm type S motion-picture camera cartridge and take-up core drive camera interface and take-up core drive (200-ft capacity)

Approved August 12, 1982

Secretariat: Society of Motion Picture and Television Engineers

Page 1 of 6 pages

1. Scope

This standard specifies the dimensions of the 8-mm Type S 200-ft [60-m] capacity motion-picture camera cartridge and cartridge-camera interface. Also specified are the dimensions of the take-up core drive opening and critical dimensions of the take-up core as well as the driving force, direction of drive, and recommended drive ratio. An optional means of retaining the film supply until the cartridge is placed in the camera is described.

2. Dimensions

- 2.1 The dimensions shall be as given in the figures and table.
- 2.2 The dimensions apply to an assembled cartridge with a film load at the time of manufacture.
- 2.3 Datum Planes B, C, and A are referred to as first, second, and third, respectively. The planes, which are used for dimensioning, are mutually perpendicular and are jointly called a datum reference frame.
- 2.3.1 Datum Plane A is coincident with the center of a circle located by basic Dimension T. The circle is in contact with the edges of the locating slot defined by Dimensions A, O, P, and Q. The diameter of this circle is such that it applies regardless of feature size (RFS) of the locating slot. (See Fig. 2 and Appendix A3.)
- 2.4 Datum Features B, C, and A are primary, secondary, and tertiary, respectively.
- 2.4.1 Datum Feature B is the unnotched, unlabeled surface of the cartridge, extending 2.00 in (50.8 mm) basic below and 1.635 in (41.53 mm) basic above Datum Plane A (cartridge surface between Dimensions Av and Cs in Fig. 1). It is the primary datum feature and contacts Datum Plane B (of a gauging fixture [see Appendix A3]) at a minimum of three points.
- 2.4.2 Datum Feature C is the front sealing surface of the cartridge, extending 2.00 in (50.8 mm) basic below and 1.635 in (41.53 mm) basic above Datum Plane A. It is the secondary datum feature and contacts Datum Plane C (of a gauging fixture [see Appendix A3]) at a minimum of two points.
- 2.5 Dimensions L, N, U, Am, V, M, W, and R3, measured from Datum Planes A and C to the depth of Dimension E, describe the extent of both triangular recessed areas. The inboard wall of the recessed area, defined by Dimensions L and N, shall be a smooth surface and may be filled sufficiently from the perpendicular to Datum Plane B to allow proper release from a mold, when the cartridge is manufactured in a molding process.
- 2.6 The thickness of the wall of the cartridge used for notching, Dimension W, shall be sufficient to withstand a force of at least 2.2 lbf (10 N), while deflecting no more than 0.04 in (1.0 mm). (For purposes of measurement, the force is applied by a solid round pin of nominal 0.05-in (1.3-mm) diameter, centered 0.03 in (0.8 mm) nominally

CAUTION NOTICE: This American National Standard may be revised or withdrawn at any time. The procedures of the American National Standards Institute require that action be taken to reaffirm, revise, or withdraw this standard no later than five years from the date of publication. Purchasers of American National Standards may receive current information on all standards by calling or writing the American National Standards Institute. Printed in USA



American National Standards Institute, 1430 Broadway, New York, N.Y. 10018
Reprinted with permission of the Society of Motion Picture and Television Engineers.

ANSI PH22.205-1982

Page 2 of 6 pages

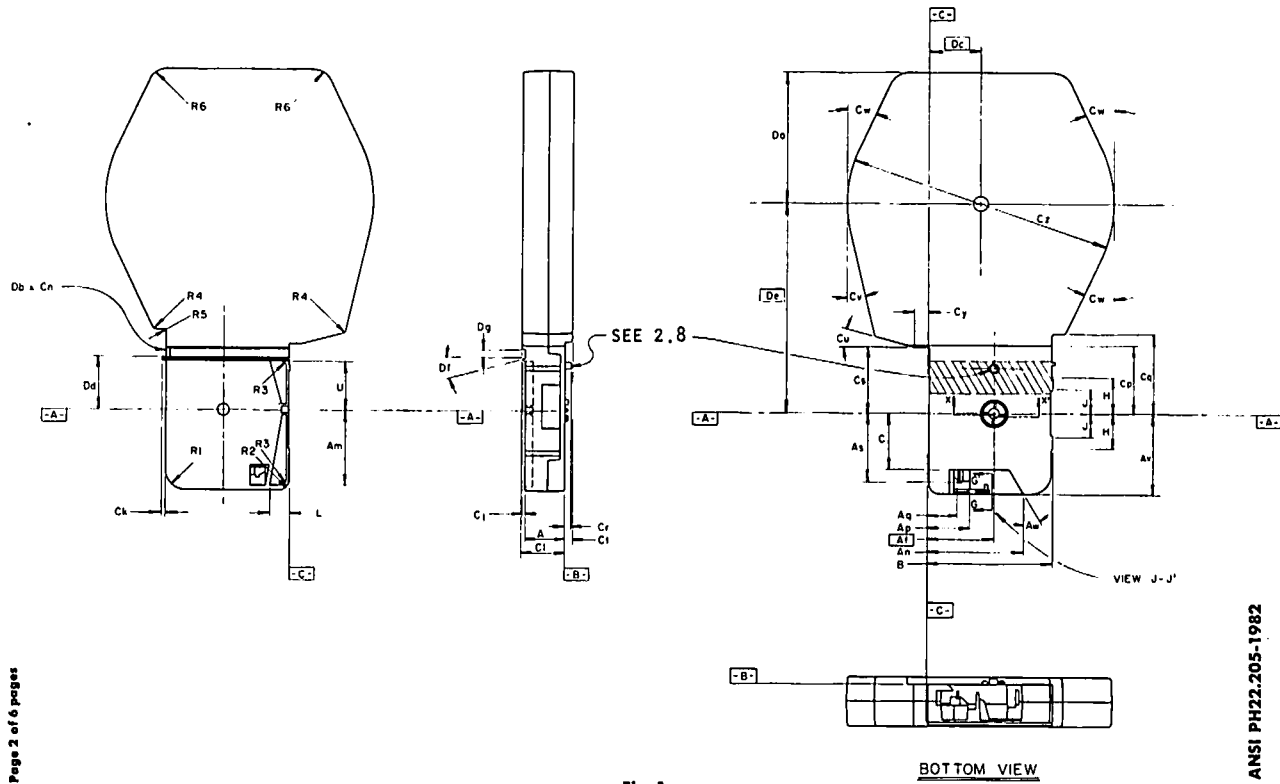

Fig. 1
Cartridge

Dimensions	Inches	Millimeters
A	0.954 ± 0.010	24.23 ± 0.25
B	2.99 ± 0.01	75.9 ± 0.3
C	1.390 ± 0.010	35.31 ± 0.25
E	0.780 max	19.81 max
F	0.090 ± 0.010	2.29 ± 0.25
G	0.06 ± 0.01	1.5 ± 0.3
H	0.88 ± 0.03	22.4 ± 0.8
J	0.61 ± 0.03	15.5 ± 0.8
K	0.015 ± 0.010	0.38 ± 0.25
L	0.470 min	11.94 min
M	0.007 ± 0.005	0.18 ± 0.13
N	0.177 min	4.50 min
O	0.154 ± 0.004	3.91 ± 0.10
P	0.142 ± 0.004	3.61 ± 0.10
Q	0.770 ± 0.010	19.56 ± 0.25
R1	0.50 ± 0.10	12.7 ± 2.5
R2	0.25 ± 0.05	6.4 ± 1.3
R3	0.160 max	4.06 max
R4	0.050 min	1.27 min
R5	0.040 max	1.02 max
R6	0.25 min	6.4 min
S	1.02 ± 0.01	25.9 ± 0.3
T	0.870 basic	22.10 basic
U	1.225 min	31.12 min
V	0.125 max	3.18 max
W	See 2.6	
Y	0.151 ± 0.012	3.84 ± 0.30
Af	1.608 basic	40.84 basic
Am	1.835 min	46.61 min
An	2.340 min	59.44 min
Ap	1.032 max	26.21 max
Aq	0.733 ± 0.008	18.62 ± 0.20
As	1.710 ± 0.012	43.43 ± 0.30
At	1.730 min	43.94 min
Au	1.890 min	48.01 min
Av	2.000 ± 0.010	50.80 ± 0.25
Aw	30° + 1° - 5°	30° + 1° - 5°
Ay	0.620 min	15.75 min
Az	0.502 min	12.75 min
Ba	0.040 ± 0.008	1.02 ± 0.20
Bb	0.319 ± 0.008	8.10 ± 0.20
Bc	1.152 min	29.26 min
Bd	0.660 max	16.76 max
Be	0.533 max	13.54 max
Bf	45° nom	45° nom

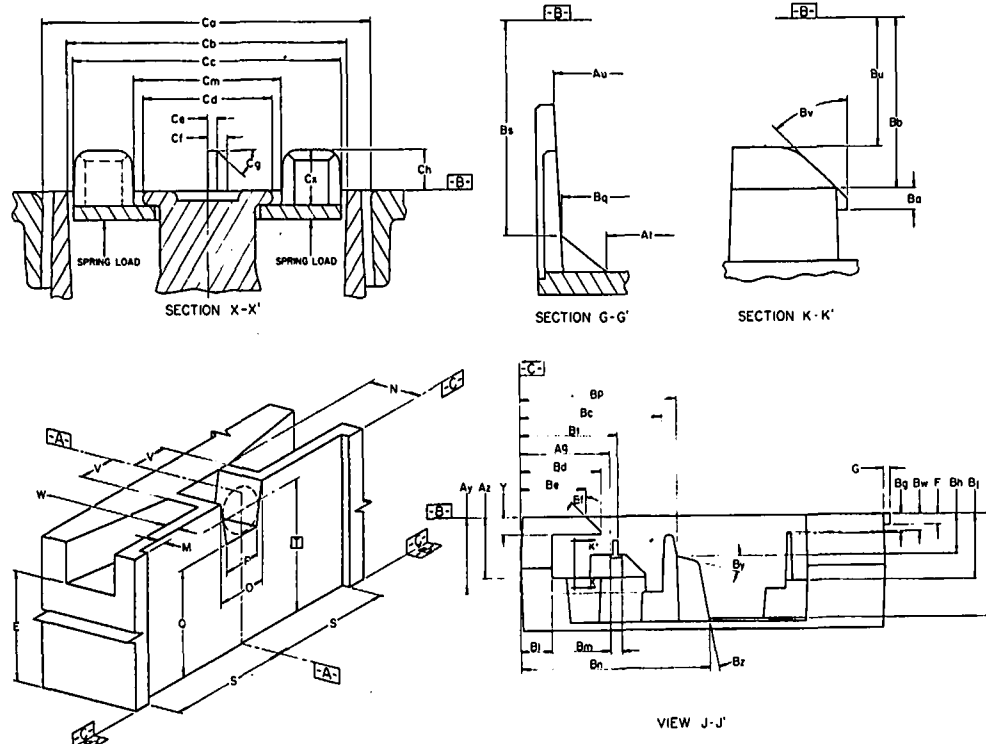

Fig. 2
Camera Locating Slot

Dimensions	Inches		Millimeters	
Bg	0.162 ± 0.015		4.11 ± 0.38	
Bh	0.347	min	8.81	min
Bi	0.502	min	12.75	min
Bj	0.840	min	21.34	min
Bk	0.260	max	6.60	max
Bl	0.093 ± 0.015		2.36 ± 0.38	
Bm	1.550	max	39.37	max
Bo	1.280	max	32.51	max
Bp	1.888	min	47.96	min
Bq	0.658	min	16.71	min
Br	0.787	max	19.99	max
Bs	0.200	min	5.08	min
Bt	45°	± 5°	45°	± 5°
Bu	0.151 ± 0.012		3.84 ± 0.30	
Bv	15°	± 2°	15°	± 2°
Bw	15°	± 2°	15°	± 2°
Bx	0.690	max	17.53	max
By	0.555	min	14.10	min
Bz	0.500	min	12.70	min
Ca	0.264	max	6.71	max
Cb	0.020	max	0.51	max
Cc	0.040 ± 0.015		1.02 ± 0.38	
Cd	45°	nom	45°	nom
Ce	0.090 ± 0.050		2.29 ± 1.27	
Cf	0.080 ± 0.010		2.03 ± 0.25	
Cg	0.065 ± 0.015		1.65 ± 0.38	
Ch	1.074	max	27.28	max
Ch	0.310	max	7.87	max
Ci	45°	nom	45°	nom
Cj	1.692 ± 0.015		42.98 ± 0.38	
Ck	1.985 ± 0.030		50.42 ± 0.76	
Cl	0.185	max	4.70	max
Cm	1.655 ± 0.020		42.04 ± 0.51	
Cn	0.165 ± 0.020		4.19 ± 0.51	
Co	15°	± 5°	15°	± 5°
Cp	13°	± 5°	13°	± 5°
Cq	25°	± 5°	25°	± 5°
Cr	0.100	min	2.54	min
Cs	0.310 ± 0.020		7.87 ± 0.51	
Ct	6.500	dia max	165.10	dia max
Cu	3.275	max	83.18	max
Cv	0.094 ± 0.020		2.39 ± 0.51	
Cw	1.246	basic	31.65	basic
Cx	1.300 ± 0.015		33.02 ± 0.38	
Cy	5.237	basic	133.02	basic
Cz	15°	± 2°	15°	± 2°
Da	0.215 ± 0.008		5.46 ± 0.20	

above or below the film speed or filter notch coincident with basic Dimension T on Datum Feature C.)

2.7 Dimension A specifies the normal overall thickness of the cartridge, extending from the bottom edge of the cartridge to the light lock rib (Dimension U) and within the light lock channel (Dimension Dg).

2.8 Some cartridge manufacturers may desire to provide a means of retaining the film supply and take-up spools until the cartridge is placed in the camera. One method employs a spool locking device which is activated by a lock pin extending through Datum Feature B. The device should be designed to unlock the spools when the lock pin is depressed by seating the cartridge on Datum Plane B (camera mechanism plate). The lock pin should be located within a zone from 0.50 in (12.7 mm) basic from Datum Plane A, within Dimension B. The force required to hold the lock pin coincident with Datum Plane B shall not exceed 20 oz (5.4 N). The initial force to depress the lock pin may be significantly higher than the force required to hold the lock pin coincident with Datum Plane B.

2.9 Dimension M is measured from Datum Plane C.

2.10 The sprocket axis shall be located within 0.010 in (0.25 mm) of the true center formed by Datum Plane A and basic Dimension Af.

2.11 Dimensions Ca, Cb, Cc, Cd, and Cm are diameters.

2.12 Dimensions Bi, Bu, and Bv define an optional guide provided to facilitate film loading at the time of cartridge manufacture.

3. Take-Up Core Drive

3.1 The direction of rotation for the core shall be clockwise when viewed from the core side of the cartridge.

3.2 After disengagement of any film locking device, the cartridge shall operate with a nominal torque of 1.3 ozfin (9.2 x 10⁻³ N·m) with a permissible range of 1.0 to 1.5 ozfin (7.1 x 10⁻³ to 10.6 x 10⁻³ N·m). (See Appendix A2.)

To enable cameras to distinguish automatically between the 8-mm Type S 200-ft (60-m) capacity cartridge and the 50-ft (15-m) capacity sound and silent cartridge, a spring-loaded drive plate is incorporated in the core drive of the 8-mm Type S 200-ft (60-m) capacity cartridge. The spring-loaded drive plate will react axially against the core drive mechanism of the camera with a nominal force of 14 oz (3.9 N) with a permissible range of 10 to 18 oz (2.8 to 5.0 N) when the spring-loaded drive plate is depressed to within 0.020 in (0.51 mm) from Datum Plane B. (Four driving lugs are shown in the core, and it is recommended that the camera core driver be designed in such a way as to present a plane surface for the four lugs to bear against.)

3.3 When operating the 200-ft (60-m) capacity cartridge loaded with film without a magnetic sound stripe, proper film transport requires that all camera film transport mechanisms, including those for recording sound, be activated. (This may not be required when using the 8-mm Type S 50-ft (15-m) capacity silent cartridge.)

Appendix

(The Appendix is not a part of this American National Standard, but is included for information purposes only.)

A1. In designing the core driver, consideration should be given to the fact that tooth-on-tooth engagement of the core lug on the driver pin is a possibility.

A2. It is recommended that the core be tendency driven (by some form of slip-drive mechanism) with a drive ratio of at least one turn of the core driver for every fourteen strokes of the pull-down claw when no slippage occurs.

A3. To provide a consistent method of measurement, it is recommended that a cartridge gauging fixture be used which incorporates datum surfaces, a locating pin, and means of exerting locating forces on appropriate surfaces of the cartridge.

American National Standard specifications for 8-mm type S model I sound motion-picture camera cartridge aperture and profile, film position, pressure pad and flatness (200-ft capacity)

Approved August 12, 1982

Secretariat: Society of Motion Picture and Television Engineers

Page 1 of 5 pages

1. Scope

This standard specifies the dimensions and location of the cartridge aperture, pressure pad, and characteristics necessary for its appropriate flatness, clearance, and location of film in the camera aperture of 200-ft (60-m) capacity 8-mm Type S Model I sound motion-picture film camera cartridges.

2. Dimensions

2.1 The dimensions shall be as given in the figures and tables.

2.2 The dimensions shown in Figs. 1 and 3 and Tables 1 and 3 apply to a cartridge that is fully assembled but does not contain film. The dimensions shown in Fig. 2 and Table 2 apply to an assembled cartridge with a film load at the time of manufacture.

2.3 The datum planes and datum features used for dimensioning are as defined in Secs. 2.3, 2.3.1, 2.4, 2.4.1, and 2.4.2 of American National Standard Specifications for 8-mm Type S Motion Picture Camera Cartridge, Cartridge-Camera Interface and Take-Up Core Drive (200-ft Capacity), ANSI PH22.205-1982.

2.4 Dimensions T and U denote the lateral location of the film in the cartridge before insertion in the camera. After insertion, Dimension T becomes 0.060 in (1.52 mm) minimum and Dimension U becomes 0.050 in (1.27 mm) minimum.

2.5 All dimensions in Table 1, except Dimensions A and C, apply at the front surface of the pres-

sure pad. A draft of 5 degrees to the recess area is permitted as well as an inside or outside radius of 0.005 in (0.13 mm) at all corners to provide satisfactory mold release when the pressure pad is manufactured in a molding process.

2.6 Dimension A denotes the space available from Datum Plane C for penetration of the camera film alignment guide wings or the camera claw into the recessed area of the cartridge pressure pad.

2.7 Dimension B is measured from Datum Plane C and determines the operating position of the cartridge pressure pad.

2.8 Dimensions relative to the surface of the pressure pad are measured from a plane established through Surfaces 1, 2, and 3, as defined by 0.060-in (1.52-mm) diameter circles dimensionally centered. (See Fig. 3.) The actual camera aperture bosses may deviate from this shape.

2.9 Dimension G₂ specifies the clearance for film in the camera aperture area, based on Dimension T₁, the thickness of the film in the center of the picture area. (See Note 1.)

2.10 Dimension G₁ specifies the extension of the camera aperture plate boss points (corresponding to 1, 2, and 3) beyond the aperture plate plane at the aperture opening.

2.11 The upper and lower pad areas extend from Dimension C₁ to the top and bottom of the cartridge pressure pad within Dimension K.

2.12 Dimension H₁ is intended to apply from a plane as described in Sec. 2.8.

CAUTION NOTICE: This American National Standard may be revised or withdrawn at any time. The procedures of the American National Standards Institute require that action be taken to reaffirm, revise, or withdraw this standard no later than five years from the date of publication. Purchasers of American National Standards may receive current information on all standards by calling or writing the American National Standards Institute. Printed in USA



American National Standards Institute, 1430 Broadway, New York, N.Y. 10018

Reprinted with permission of the Society of Motion Picture and Television Engineers.

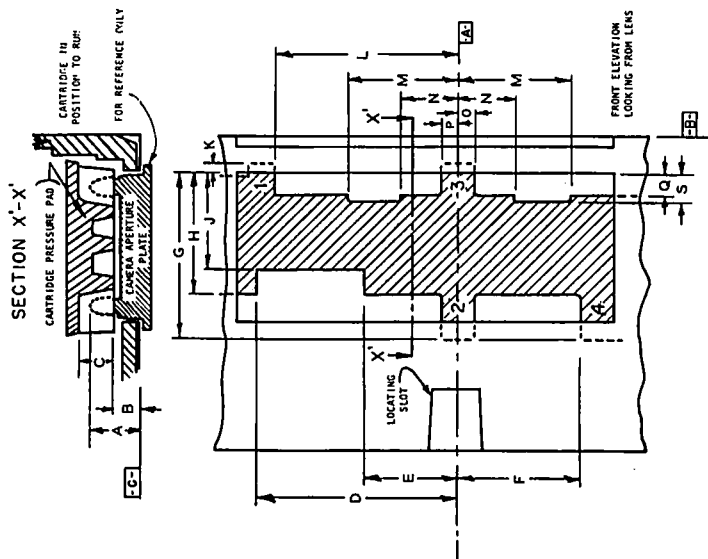

Fig. 1
Cartridge Pressure Pad

Table 1

Dimensions	Inches		Millimeters	
	max	min	max	min
A	0.150	± 0.005	3.81	max
B	0.077	± 0.005	1.96	± 0.13
C	0.090	min	2.29	min
D	0.540	min	13.72	min
E	0.260	max	6.60	max
F	0.360	± 0.020	9.14	± 0.51
G	0.455	min	11.56	min
H	0.365	max	9.27	max
J	0.300	min	7.62	min
K	0.000	min	0.00	min
L	0.540	± 0.020	13.72	± 0.51
M	0.300	min	7.62	min
N	0.140	max	3.56	max
O	0.058	± 0.022	1.47	± 0.56
P	0.038	± 0.022	0.97	± 0.56
Q	0.055	min	1.40	min
S	0.090	min	2.29	min

ANSI PH22.206-1982

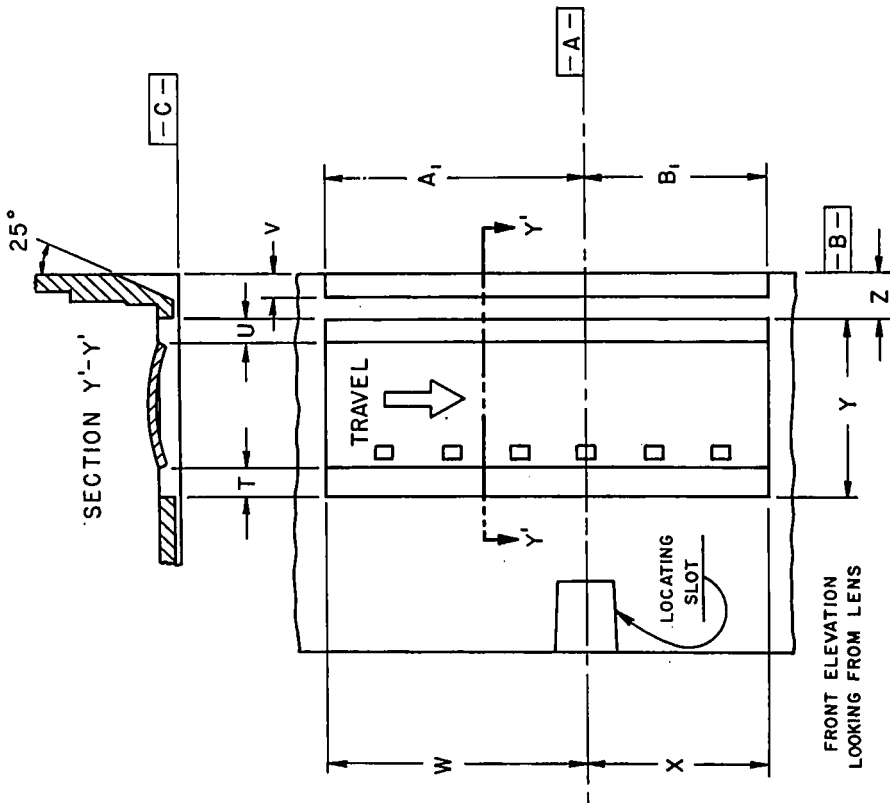

Fig. 2
Cartridge Aperture Opening and Film Position

Table 2

Dimensions	Inches		Millimeters	
	min	max	min	max
T	0.050	0.061	1.27	1.55
U	0.040	0.048	1.02	1.22
V	0.061	0.066	1.55	1.68
W	0.648	0.653	16.46	16.63
X	0.451	0.456	11.46	11.68
Y	0.451	0.456	11.46	11.68
Z	0.111	0.116	2.82	2.94
A ₁	0.642	0.647	16.31	16.43
B ₁	0.445	0.450	11.30	11.43

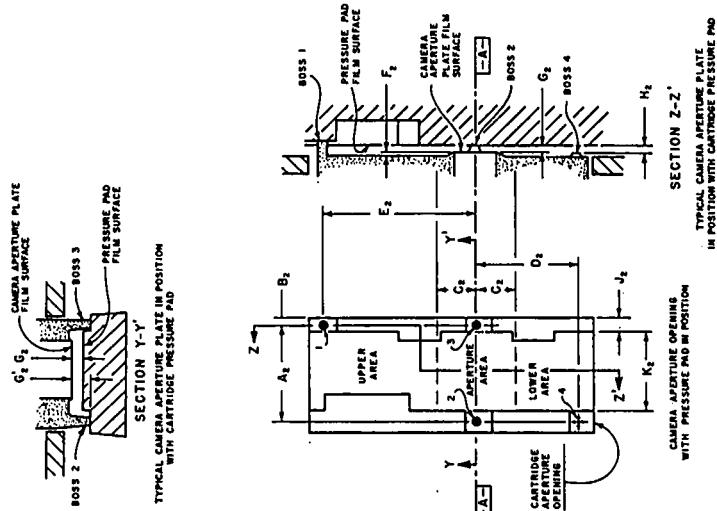

Fig. 3
Pressure Pad Flatness Reference Surfaces

Table 3
Pressure Pad Dimensions

Dimensions	Inches		Millimeters	
	min	max	min	max
A ₃	0.378	0.383	9.60	9.73
B ₃	0.030	0.035	0.76	0.89
C ₃	0.153	nom	3.89	nom
D ₃	0.393	0.398	9.98	10.11
E ₃	0.590	0.595	14.99	15.12
F ₃	0.005	min	0.13	min
G ₃	T ₃ + 0.0007	min	T ₃ + 0.018	min
	T ₃ + 0.0012	max	T ₃ + 0.030	max
G' ₃	0.0065	min	0.165	min
	0.0070	max	0.178	max
H ₃	0.004	min	0.10	min
J ₃	0.055	min	1.40	min
K ₃	0.310	max	7.87	max